

# V RACK Operation Manual



**Obtaining Other Language Versions:** To obtain information in another language about the use of this product, please contact your local Crown Distributor. If you need assistance locating your local distributor, please contact Crown at 574-294-8000.

This manual does not include all of the details of design, production, or variations of the equipment; nor does it cover every possible situation which may arise during installation, operation or maintenance.

The information provided in this manual was deemed accurate as of the publication date; however, updates to this information may have occurred. To obtain the latest version of this manual, please visit the Crown website at [www.crownaudio.com](http://www.crownaudio.com).

**Trademark Notice:** Crown, Crown Audio, IQ, BCA, and Amcron are registered trademarks of Crown International. HiQnet is a trademark of Harman International Industries, Inc. Other trademarks are the property of their respective owners.

**Some models may be exported under the name Amcron<sup>®</sup>.**

©2011 by Harman International. 1718 W. Mishawaka Rd., Elkhart, Indiana 46517-9439 U.S.A. Telephone: 574-294-8000.

# Important Safety Instructions

1. Read these instructions.
2. Keep these instructions.
3. Heed all warnings.
4. Follow all instructions.
5. Do not use this apparatus near water.
6. Clean only with a dry cloth.
7. Do not block any ventilation openings. Install in accordance with the manufacturer's instructions.
8. Do not install near any heat sources such as radiators, heat registers, stoves, or other apparatus (including amplifiers) that produce heat.
9. Do not defeat the safety purpose of the polarized or grounding-type plug. A polarized plug has two blades with one wider than the other. A grounding-type plug has two blades and a third grounding prong. The wide blade or the third prong is provided for your safety. If the provided plug does not fit into your outlet, consult an electrician for replacement of the obsolete outlet.
10. Protect the power cord from being walked on or pinched, particularly at plugs, convenience receptacles, and the point where they exit from the apparatus.
11. Only use attachments/accessories specified by the manufacturer.
12. Use only with a cart, stand, tripod, bracket, or table specified by the manufacturer, or sold with the apparatus. When a cart is used, use caution when moving the cart/apparatus combination to avoid injury from tip-over.
13. Unplug this apparatus during lightning storms or when unused for long periods of time.
14. Refer all servicing to qualified service personnel. Servicing is required when the apparatus has been damaged in any way, such as power-supply cord or plug is damaged, liquid has been spilled or objects have fallen into the apparatus, the apparatus has been exposed to rain or moisture, does not operate normally, or has been dropped.
15. Use the mains plug to disconnect the apparatus from the mains.
16. **WARNING: TO REDUCE THE RISK OF FIRE OR ELECTRIC SHOCK, DO NOT EXPOSE THIS APPARATUS TO RAIN OR MOISTURE.**
17. **DO NOT EXPOSE THIS EQUIPMENT TO DRIPPING OR SPLASHING AND ENSURE THAT NO OBJECTS FILLED WITH LIQUIDS, SUCH AS VASES, ARE PLACED ON THE EQUIPMENT.**
18. **THE MAINS PLUG OF THE POWER SUPPLY CORD SHALL REMAIN READILY OPERABLE.**



TO PREVENT ELECTRIC SHOCK, DO NOT REMOVE TOP OR BOTTOM COVERS. NO USER SERVICEABLE PARTS INSIDE. REFER SERVICING TO QUALIFIED SERVICE PERSONNEL.



TO COMPLETELY DISCONNECT THIS EQUIPMENT FROM THE AC MAINS, DISCONNECT THE POWER SUPPLY CORD PLUG FROM THE AC RECEPTACLE. THE MAINS PLUG OF THE POWER SUPPLY CORD SHALL REMAIN READILY OPERABLE.

## WATCH FOR THESE SYMBOLS:



The lightning bolt triangle is used to alert the user to the risk of electric shock.



The exclamation point triangle is used to alert the user to important operating or maintenance instructions.



## IMPORTANT



VRacks require Class 2 output wiring.

## MAGNETIC FIELD

CAUTION! Do not locate sensitive high-gain equipment such as preamplifiers or tape decks directly above or below the unit. Because this amplifier has a high power density, it has a strong magnetic field which can induce hum into unshielded devices that are located nearby. The field is strongest just above and below the unit.

If an equipment rack is used, we recommend locating the amplifier(s) in the bottom of the rack and the preamplifier or other sensitive equipment at the top.

## FCC COMPLIANCE NOTICE

This device complies with part 15 of the FCC rules. Operation is subject to the following two conditions: (1) This device may not cause harmful interference, and (2) this device must accept any interference received, including interference that may cause undesired operation.

CAUTION: Changes or modifications not expressly approved by the party responsible for compliance could void the user's authority to operate the equipment.

NOTE: This equipment has been tested and found to comply with the limits for a Class B digital device, pursuant to part 15 of the FCC Rules. These limits are designed to provide reasonable protection against harmful interference in a residential installation. This equipment generates, uses, and can radiate radio frequency energy and, if not installed and used in accordance with the instruction manual, may cause harmful interference to radio communications. However, there is no guarantee that interference will not occur in a particular installation. If this equipment does cause harmful interference to radio or television reception, which can be determined by turning the equipment off and on, the user is encouraged to try to correct the interference by one or more of the following measures:

- Reorient or relocate the receiving antenna.
- Increase the separation between the equipment and receiver.
- Connect the equipment into an outlet on a circuit different from that to which the receiver is connected.
- Consult the dealer or an experienced radio/TV technician for help.

# DECLARATION OF CONFORMITY

**Issued By:** Harman International.  
1718 W. Mishawaka Rd.  
Elkhart, IN 46517 U.S.A.

FOR FIELD SERVICE  
QUESTIONS CALL: 1 800 342 6939

## European Representative's Name and Address:

David J. Budge  
10 Harvest Close  
Yateley, GU46 6YS  
United Kingdom

**Equipment Type:** Commercial Audio Power Amplifiers

**Family Name:** ITECH-HD

**Model Names:** VRack

## EMC Standards:

**EN 55103-1:1997** Electromagnetic Compatibility - Product Family Standard for Audio, Video, Audiovisual and Entertainment Lighting Control Apparatus for Professional Use, Part 1: Emissions

**EN 55103-1:1997** Magnetic Field Emissions-Annex A @ 10 cm and 20 cm

**EN 61000-3-2:2005 & Amd 1: 2008** Limits for Harmonic Current Emissions (equipment input current ≤16A per phase)

**EN 61000-3-3:1998** Limitation of Voltage Fluctuations and Flicker in Low-Voltage Supply Systems Rated Current ≤16A

**EN 55022:2006** Limits and Methods of Measurement of Radio Disturbance Characteristics of ITE: Radiated, Class B Limits; Conducted, Class A

**EN 55103-2:1997** Electromagnetic Compatibility - Product Family Standard for Audio, Video, Audiovisual and Entertainment Lighting Control Apparatus for Professional Use, Part 2: Immunity

**EN 61000-4-2:2001** Electrostatic Discharge Immunity (Environment E2-Criteria B, 4k V Contact, 8k V Air Discharge)

**EN 61000-4-3:2006** Radiated, Radio-Frequency, Electromagnetic Immunity (Environment E2, Criteria A)

**EN 61000-4-4:2007** Electrical Fast Transient/Burst Immunity (Criteria B)

**EN 61000-4-5:2006** Surge Immunity (Criteria B)

**EN 61000-4-6:2006** Immunity to Conducted Disturbances Induced by Radio-Frequency Fields (Criteria A)

**EN 61000-4-11:2004** Voltage Dips, Short Interruptions and Voltage Variation

## Safety Standard:

**IEC 60065: 2001: 7Ed & Amd 1: 2005** Safety Requirements - Audio Video and Similar Electronic Apparatus

I certify that the product identified above conforms to the requirements of the EMC Council Directive 89/336/EEC as amended by 92/31/EEC, and the Low Voltage Directive 73/23/EEC as amended by 93/68/EEC.

Signed

Scott Potosky

Title: Director of Engineering

Date of Issue: February 1, 2010

# Table of Contents

<b>Features</b> .....	5
<b>Setup</b> .....	6
VRack Power Distribution Overview .....	9
I-Tech HD Amplifier Specifications.....	12
<b>Input Panel</b> .....	15
<b>Input Wiring Modes</b> .....	16
Analog .....	16
Digital .....	21
Hybrid .....	24
<b>Network Wiring Schematic</b> .....	26
<b>VDrive</b> .....	27
<b>Output Panel</b> .....	28
<b>Output Wiring Modes</b> .....	29
<b>HiQnet™ Software</b> .....	38
<b>System Diagrams</b> .....	43
<b>Product Registration</b> .....	51
<b>Crown Audio Factory Service Information</b> .....	53

# Welcome

The VRack is comprised of a rugged touring rack fitted with three Crown IT12000HD amplifiers, a power input panel, and custom engineered input and output panels. The input panel is mounted at the top rear and supplies CobraNet(TM) network connections as well as AES/EBU and analog XLR connections. The output panel on the bottom rear of the rack offers 12 Speakon outputs: 3 x 2-way NL4 outputs, 6 x 1-way NL4 outputs, and 3 x 3-way NL8 outputs. The front-mounted power panel includes a 5-pin Hubbell Twist-Lock connector and a 5-pin CEE-Form connector.

Because the VRack is supplied with all components installed and internally connected, there is no need for laborious rack building; no chance that a component might be improperly connected; and a dramatically lower chance of connection failure.

The VRack is best thought of not as just an amp rack, but as a building block for your system. Every time you add 1 VRack into a system, you are adding 1 block that powers a proper 3:2 ratio of tops and subs for optimal performance, and seamlessly integrates into your system via analog or digital connections.

Each IT12000HD has 2 channels, each one capable of 2100 watts into 8 ohms and 4500 watts into 4 ohms. The input and output panels are both engineered by Crown to give the VRack user optimum flexibility when deploying a VRack system for powering VerTec fullsize (VT4889), midsize (VT4888), compact (VT4887A), subcompact (VT4886) models, companion subwoofers (VT4880, VT4880A, VT4881A, VT4882, VT4883), and the latest JBL VTX and STX800 models.

The input panel automatically buffers AES signals, reducing or eliminating the need for digital distribution amplifiers. Through VDrive (pg.27), the user is able to run Ethernet control and AES digital audio over a single Cat5 which jumps from rack to rack.

The output panel is designed to offer easy configuration for a variety of PA systems. It gives the ability to run tops off NL8 and subs off NL4s, monitors or fills off 2-way NL4 outputs, or for VT4887A/VT4881A and VT4886/VT4883 systems, an entire circuit of tops+subs off a single NL8. See pg.28 for output panel and a summary of wiring configurations.

VRack is manufactured and tested to a single meticulous standard, and then shipped around the world. This means that any time you supply or cross-rent a VRack it is the same as every other VRack in the world.

# Features

- 3 IT12000HD amplifiers
- Fully assembled package from one source
- Worldwide power distribution with both L21-30 and 32A CEE-Form connections
- Flexible input panel with Analog, AES, and VDrive
- Versatile output panel
- Fail-over AES and network connection
- Rear rack lighting
- VDrive AES digital distribution over CAT5
- Built-in network control
- Built-in captive suspension
- Shock-mounted rack
- Removable dolly board
- Side-storing rack doors
- Entire package is UL/CSA/ETL
- HiQnet™ control

### Rack Specific

Weight: 184 lbs (84.5 kg)

Dimensions:

L x W x H with caster plate – 22 ½" X 23 ½" X 31 ¼" ( 57.2 cm X 59.7 cm X 79.4 cm )

L x W x H without caster plate – 22 ½" X 23 ½" X 25 7/8" (57.2 cm X 59.7 cm X 65.7 cm)

**Front View (23-1/2" x 31-1/4")**



**Side View (22-1/2" x 31-1/4")**



**Top View (23-1/2" x 22-1/2")**

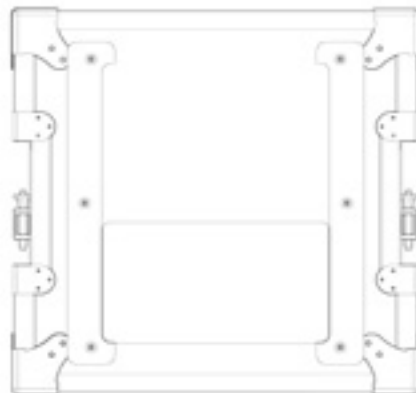

**Bottom View (22-1/2" x 23-1/2")**

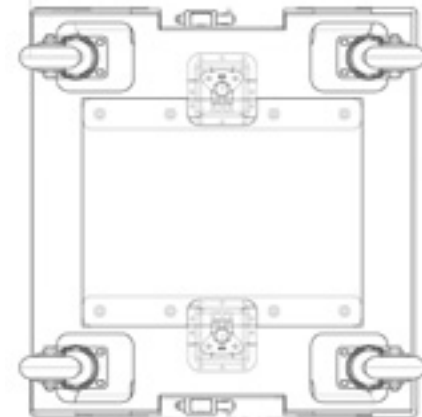

### Rack-Specific Info:

- Colson 3 ½" polyurethane casters rated at 250 lbs (113 kg) per caster
- Polycarbonate, UV stabilized, "virtually unbreakable" front see-through door with 30x the impact resistance of acrylic
- Shock mounting using 8 neoprene rubber isolators rated at 90 lbs (41 kg) vertical and 30 lbs (13.6 kg) horizontal with steel insert
- Captive pocket door system with a single-slam latch
- Removable caster plate with interlocking stacking system

### Suspension

**Safety Precautions:** Before attempting to suspend your speakers or power amplifier rack, read and understand the following safety information.

### Important Suspension Safety Warning!

The information in this section has been assembled from recognized engineering data and is intended for informational purposes only. None of the information in this section should be used without first obtaining competent advice with respect to applicability to a given circumstance. None of the information presented herein is intended as a representation or warranty on the part of Crown. Anyone making use of this information assumes all liability arising from such use.

All information presented herein is based upon materials and practices common to North America and may not directly apply to other countries because of differing material dimensions, specifications, and/or local regulations. Users in other countries should consult with appropriate engineering and regulatory authorities for specific guidelines.

Correct use of all hardware is required for secure system suspension. Careful calculations should always be performed to ensure that all components are used within their rated workload before the array is suspended. Never exceed maximum recommended load ratings.

Before suspending any speaker system or power amplifier rack, always inspect all components (enclosure, suspension frames, pins, etc.) for cracks; deformation; corrosion; missing, loose or damaged parts that could reduce strength and safety of the array. Do not suspend the speaker or power amplifier rack until the proper corrective action has been taken. Use only load-rated hardware when suspending the VRack.

### Are You New to Suspension?

If you are new to suspension, you should do the following:

- Read and study.
- Know the Rules for Safe Suspension.
- Attend a safe suspension seminar, such as that presented by professionals like Suspension Seminars™ or by Chain Motor Hoist manufacturers like Columbus McKinnon Corp. (manufacturers of the C/M Lodestar).
- Meet and establish a relationship with a licensed mechanical or structural engineer. Get in the habit of asking them questions instead of guessing about their answers. Learn from what they tell you.
- Meet and discuss this aspect of your business with your Insurance Agent.
- Research and understand the codes, practices, and requirements in the venues where you intend to operate your system.

### General Hardware Information

Any hardware used in an overhead suspension application must be load rated for the intended use. Generally, this type of hardware is available from suspension supply houses, industrial supply catalogs and specialized suspension distributors. Local hardware stores do not usually stock these products.

### Attachment to Structures

A licensed Professional Engineer must approve placement and method of attachment to structures prior to installation of any overhead object. The following performance standards should be provided to the Professional Engineer for design purposes: Uniform Building Code as applicable, Municipal Building Code as applicable, Seismic Code as applicable. Installation of hardware and method of attachment must be carried out in the manner specified by the Professional Engineer. Improper installation may result in damage, injury or death.

### Suspension Hardware Inspection & Maintenance

Suspension systems are comprised of mechanical devices and, as such, they require regular inspection and routine maintenance to ensure proper function ability. The Crown VRack must be inspected for fatigue at least annually. The inspection shall include a visual survey of all corners and load-bearing surfaces for signs of cracking, water damage, de-lamination, or any other condition that may decrease the strength of the power amplifier rack enclosure. Accessory suspension hardware provided with or for the Crown VRack must be inspected for fatigue at least annually. The inspection shall include a visual material survey for signs of corrosion, bending or any other condition that may decrease strength of the fastener. For other fittings used, refer to the manufacturer's inspection and maintenance guidelines for process.

*Crown is not responsible for the application of its products for any purpose or the misuse of this information for any purpose. Furthermore, Crown is not responsible for the abuse of its products caused by avoiding compliance with inspection and maintenance procedures or any other abuse. Prior to suspending the system, an expert trained and experienced in flying loudspeaker and power amplifier systems should inspect all suspension parts and components.*

### Industry Resources

Allen Products  
562-424-1100  
1635 E. Burnett Street  
Signal Hill, CA 90755  
www.adapttechgroup.com

McMaster Carr  
Various locations throughout the U.S.A.  
For a location near you, visit them online:  
www.mcmastercarr.com

M.A.N. Flying Systems  
20 Sidar Road Brook Road  
Industrial Estate  
Rayleigh, Essex SS6 7XF U.K.  
www.manfly.co.uk

### Safe Suspension

The Crown VRack is equipped with integral suspension hardware and should only be suspended using the supplied equipment. The system is designed to facilitate the suspension of the VRacks by a qualified person familiar with suspension hardware and industry practices. Improper installation may result in damage, injury or death.

### Working Load Limit

The working load limit (WLL) for any group of VRack products is noted on the appropriate VRack Array Frame. If interested in suspending your VRacks, contact your local Crown representative for information on ordering VRack Suspension Frame.

### VRack Connectors

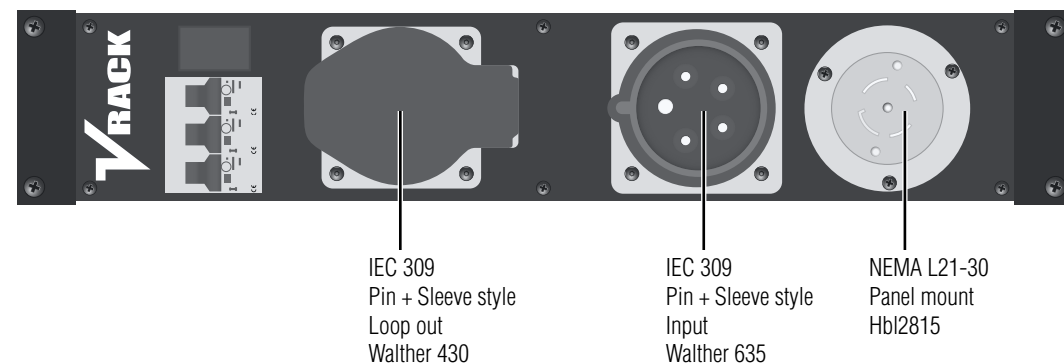

### Type of Connectors to Use with VRack

#### L21-30

Mcaster-Carr  
Female: 7184K35  
Male: 7184K34

Hubbel Catalog  
Female: HBL2813  
Male: HBL2811

#### IEC 309 Pin + Sleeve

Walther-Electric  
Female: 330  
Male: 230

Cooper Crouse-Hinds  
Female: CH532C6W  
Male: CH532P6W

### VRack Power Distribution Overview

The VRack Power Distribution panel offers worldwide use capabilities as well as multiple AC operations when used with 120VAC input. This power distribution system allows 120VAC input to 120VAC output, 120VAC input to 208VAC output when used with 3 phase power, 220VAC – 240VAC input to 220VAC – 240VAC output. It also features a 32A per circuit, 3-pole, single-throw breaker as well as an LCD readout that indicates AC Voltage. Built-in +5V and +12V outputs power the VRack's built-in network switch and rear rack lighting features. Combine this worldwide capable power distro with the I-Tech HD's Universal, Power-Factor-Corrected Power Supply and the VRack can be used anywhere in the world.

### Hubbell L21-30 U.S. Operation

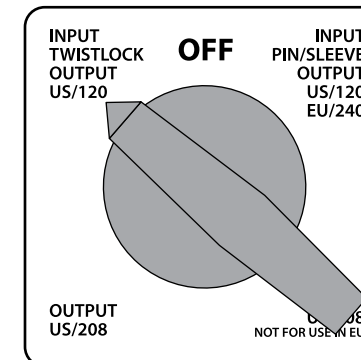

### Hubbell L21-30 120VAC Operation

Switch position "Input Twistlock, Output US/120" provides the user with 120V operation to the I-Tech HD amplifiers in the rack. From an external power distribution system, send 3 phase 120VAC power to the X, Y, and Z pin of the Hubbell connector and the VRack will operate in 120V mode. Each I-Tech HD amplifier will see a dedicated X, Y, or Z phase to the line input, neutral, and Ground connection.

**Amp 1 = X, Neutral, and GND**

**Amp 2 = Y, Neutral, and GND**

**Amp 3 = Z, Neutral, and GND**

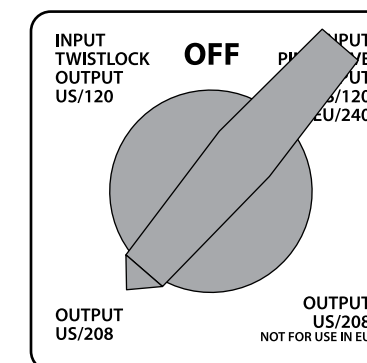

### Hubbell L21-30 208VAC Operation

Switch Position "Input Twistlock, Output US/208" provides the user with 208VAC operation to the I-Tech HD amplifiers in the rack. From an external power distribution system, send 3 phase 120VAC power to the X, Y, and Z pin of the Hubbell connector and the VRack will operate in 208V mode. Each I-Tech HD amplifier will see a dedicated line-to-line and ground connection resulting in the VRack operating in 208VAC mode.

**Amp 1 = X, Y, and GND**

**Amp 2 = Y, Z, and GND**

**Amp 3 = X, Z, and GND**

### Cee-Form U.S. Operation

#### Cee-Form 120VAC Operation

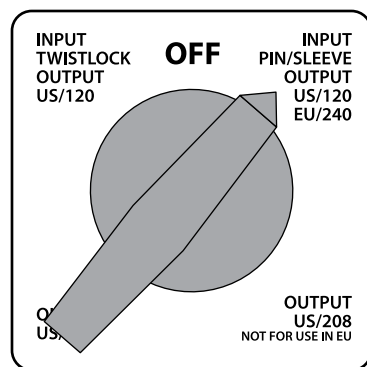

Switch Position "Input Pin/Sleeve, Output US/120 EU/240" provides 120VAC operation from the Cee-Form pin and sleeve connector. From an external power distribution system, send 3 phase 120VAC power to the X, Y, and Z pin of the Cee-Form connector and the VRack will operate in 120VAC operation mode. Each I-Tech HD amplifier will see a dedicated line-to-neutral connection as well as a ground. Once the Cee-Form connector is landed to the VRack, one can link to the next VRack using a Cee-Form jumper cable. (**\*\*\*To link VRacks using this method at 110VAC-120VAC, the end user must ensure they have proper AC current available. Also, please refer to the I-Tech HD Thermal and Current Draw specifications to ensure you are not overloading the AC lines, resulting in breakers opening. It is recommended if you wish to link VRacks, they be operated at 220VAC-240VAC.**)

Amp 1 = X, Neutral, and GND

Amp 2 = Y, Neutral, and GND

Amp 3 = Z, Neutral, and GND

#### Cee-Form 208VAC Operation

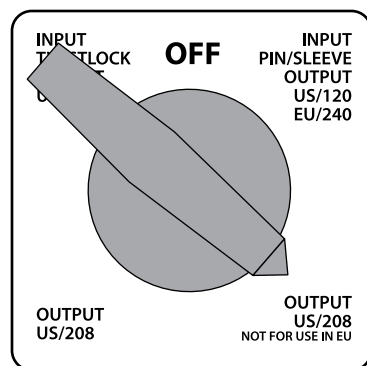

Switch Position "Input Pin/Sleeve, Output US/208" provides 208VAC Operation from the Cee-Form pin and sleeve connector. From an external power distribution system, send 3 phase 120VAC power to the X, Y, and Z pin of the Cee-Form connector and the VRack will operate in 208VAC operation mode. Each I-Tech HD amplifier will see a dedicated line-to-line connection as well as ground. In "Input Pin/Sleeve, Output US/208" mode, the end user is able to link 2 VRacks together. Amp 1 = X, Y, and GND

Amp 2 = Y, Z, and GND

Amp 3 = X, Z, and GND

### Cee-Form Non-U.S. Operation

#### Cee-Form 220VAC-240VAC Operation

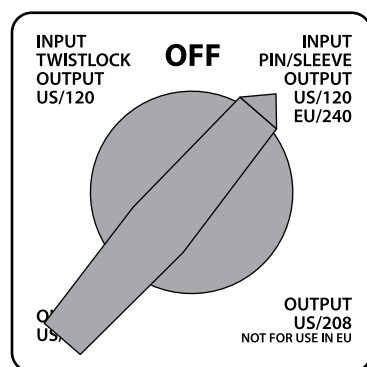

Switch Position "Input Pin/Sleeve, Output US/120 EU/240" provides 220VAC-240VAC operation from the Cee-Form pin and sleeve connector. From an external power distribution system, send 3 phase 220VAC-240VAC power to the X, Y, and Z pin of the Cee-Form connector and the VRack will operate in 220VAC-240VAC operation mode. Each I-Tech HD amplifier will see a dedicated line-to-neutral connection as well as a ground. Once the Cee-Form connector is landed to the VRack, one can link to the next VRack using a Cee-Form jumper cable. (**\*\*\*To link VRacks using this method at 220VAC-240VAC, the end user must ensure they have proper AC current available. Also, please refer to the I-Tech HD Thermal and Current Draw specifications to ensure you are not overloading the AC lines, resulting in breakers opening. It is recommended if you wish to link VRacks, they be operated at 220VAC-240VAC.**)

Amp 1 = X, Neutral, and GND

Amp 2 = Y, Neutral, and GND

Amp 3 = Z, Neutral, and GND

### Power Supply Schematic

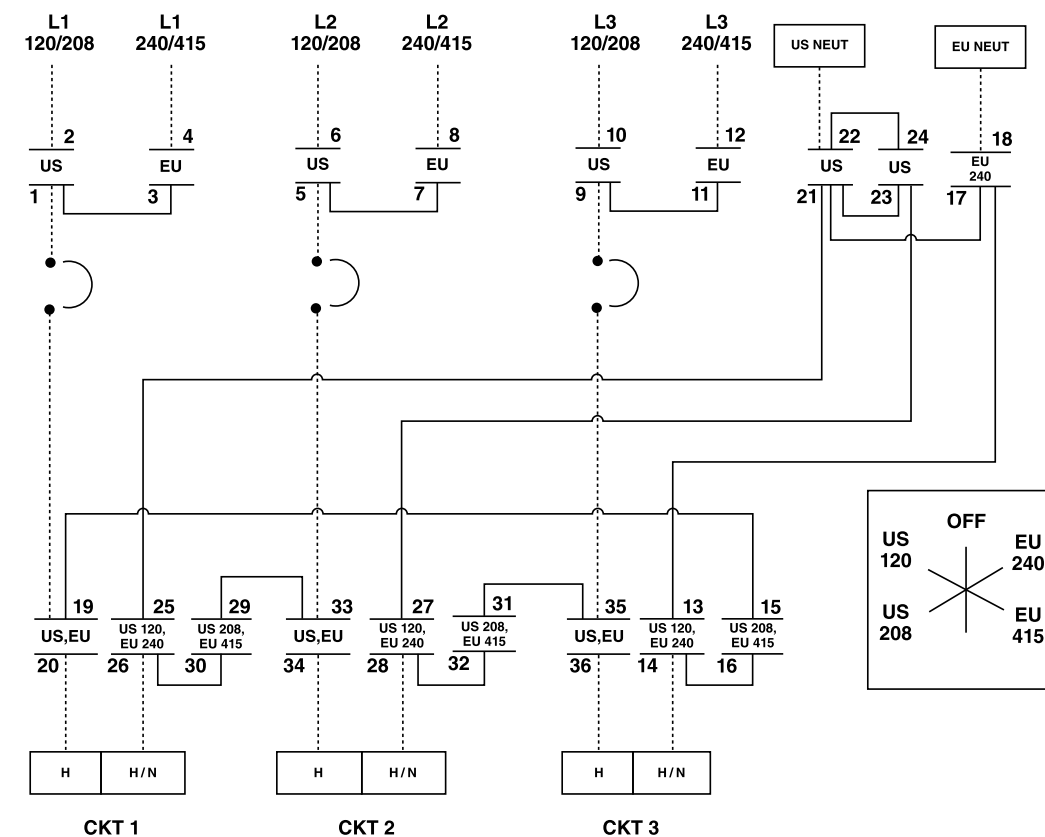

# I-Tech HD Amplifier Specifications

The Crown® I-Tech HD Series offers amazing power, light weight and ease of use for tour sound applications. Unlike other amplifiers, it includes onboard high-definition DSP, an LCD control screen, and a built-in network connection.

Modern power amplifiers are sophisticated pieces of engineering capable of producing extremely high power levels. They must be treated with respect and correctly installed if they are to provide the many years of reliable service for which they were designed.

In addition, I-TechHD Series amplifiers include a number of features which require some explanation before they can be used to their maximum advantage. Please take the time to study this manual so that you can obtain the best possible service from your amplifier.

For more information please refer to I-Tech HD manual.

## Features

- Global Power Supply with PFC (Power Factor Correction) works anywhere in the world
- High power density, up to 8000 watts in a 2U chassis
- Highest output voltage in the industry (200V peak) provides clean transient peaks
- Third-generation patented Class I (BCA®) circuitry couples power efficiently to the load and provides low AC current draw
- Onboard high-definition DSP with 24-bit, 192 kHz Cirrus Logic SHARC A/D and D/A converters; advanced IIR filters and linear phase FIR filters
- Pushbutton presets simplify setup; custom presets for various loudspeakers can be downloaded or created
- AES/EBU digital audio input
- EtherCon® Ethernet connector for HiQnet™ control or CobraNet™ digital audio transport – this “Single Plug” connection allows HiQnet™ protocol and CobraNet™ digital audio through the same CAT 5 cable
- Analog and digital thru connectors
- LCD Control Screen is used to adjust the amplifier’s attenuation and muting, configure the amp, set up and view error monitoring, and recall DSP presets to reconfigure the amp for various applications
- Comprehensive array of indicators provide accurate diagnostics: Power, Data, along with Ready, Signal, Clip, Thermal and Fault for each channel
- AC mains indicator in power switch glows green when AC power is present
- Front-panel USB connector accepts a USB drive to transfer presets from the drive to the amplifier DSP, and vice versa
- Lightweight due to aluminum chassis, special internal construction and switching power supply
- Thermal management controller and two discrete thermal zones with variable-speed fans, forced-air cooling
- Advanced protection circuitry guards against: shorted outputs, DC, mismatched loads, general overheating, under/over voltage, high-frequency overloads and internal faults
- Five-Year, No-Fault, Fully Transferable Warranty completely protects your investment and guarantees its specifications



# Front Panel Features

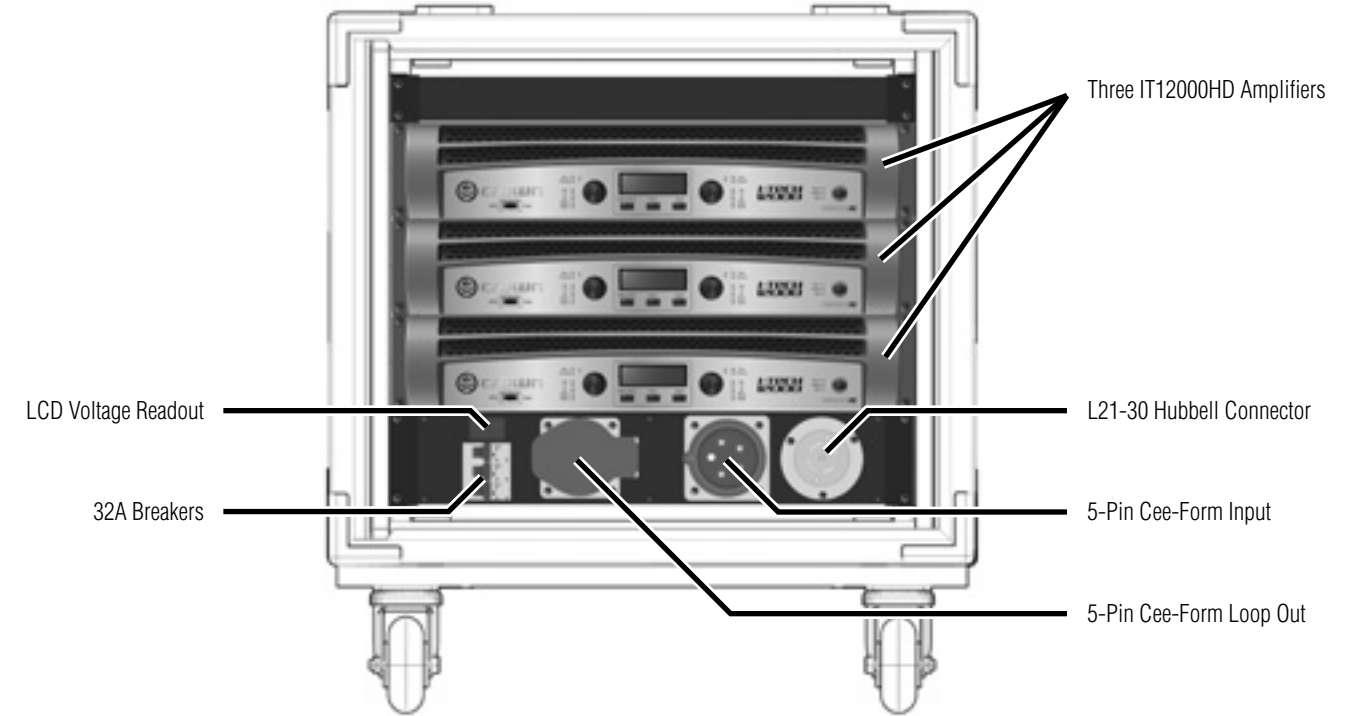

# Back Panel Features

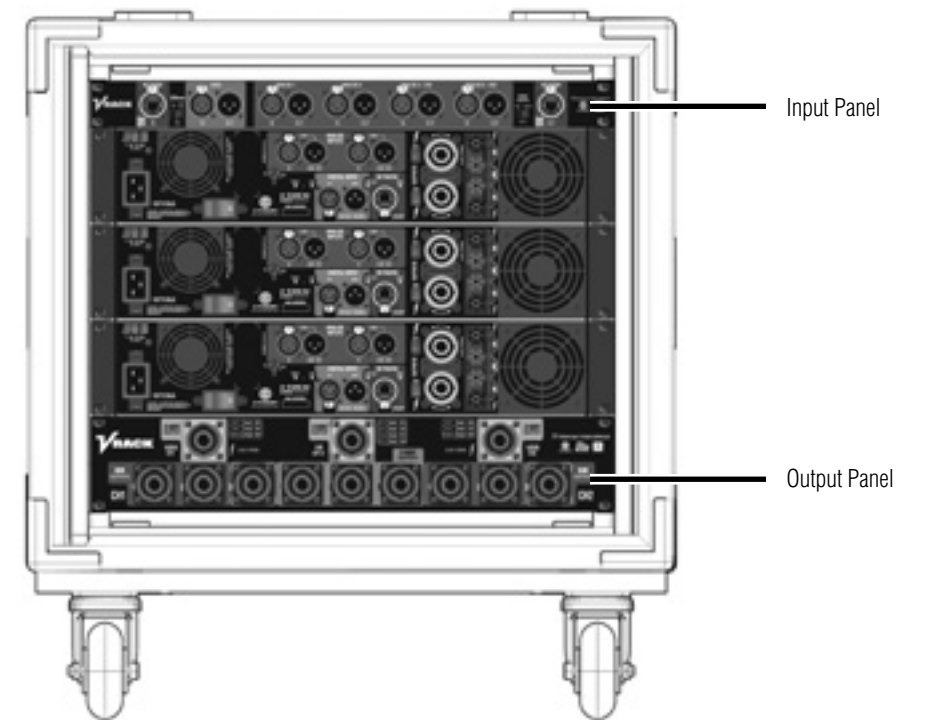

# Setup

## Choose Input Wire and Connectors

Crown recommends using pre-built or professionally wired, balanced line (two-conductor plus shield), 22-24 gauge cables with 3-pin XLR connectors. Unbalanced line may also be used but may result in noise over long cable runs.

Figure 1 shows connector pin assignments for balanced analog wiring or AES/EBU digital wiring. **(The use of standard analog cable with AES/EBU will result in diminished performance)** For best results, 110 ohm shielded twisted-pair cable for AES/EBU signals is highly recommended. Figure 2 shows connector pin assignments for unbalanced analog wiring.

NOTE: Custom wiring should only be performed by qualified personnel.

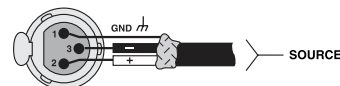

Figure 1  
Balanced Analog Input Connector Wiring or  
AES/EBU Digital Connector Wiring



Figure 2  
Unbalanced Analog Input Connector Wiring

## Choose Output Wire and Connectors

Crown recommends using pre-built or professionally wired, high-quality, two-, four- or eight-conductor, heavy gauge speaker wire and connectors. Use Class 2 output wiring. You may use a 4- or 8-pole Speakon® connector. To prevent the possibility of short circuits, wrap or otherwise insulate exposed loudspeaker cable connectors.

**CAUTION – SHOCK HAZARD: Potentially lethal voltages exist at the output connectors when the amplifier is turned on and is passing a signal.**

Using the guidelines below, select the appropriate size of wire based on the distance from amplifier to speaker.

Distance	Wire Size
up to 25 ft. (up to 7.62 m)	16 AWG
26-40 ft. (7.62-12.2 m)	14 AWG
41-60 ft. (12.2-18.3 m)	12 AWG
61-100 ft. (18.3-30.5 m)	10 AWG
101-150 ft. (30.5-45.7 m)	8 AWG
151-250 ft. (45.7-76.2 m)	6 AWG

CAUTION: Never use shielded cable for output wiring.

# Input Panel

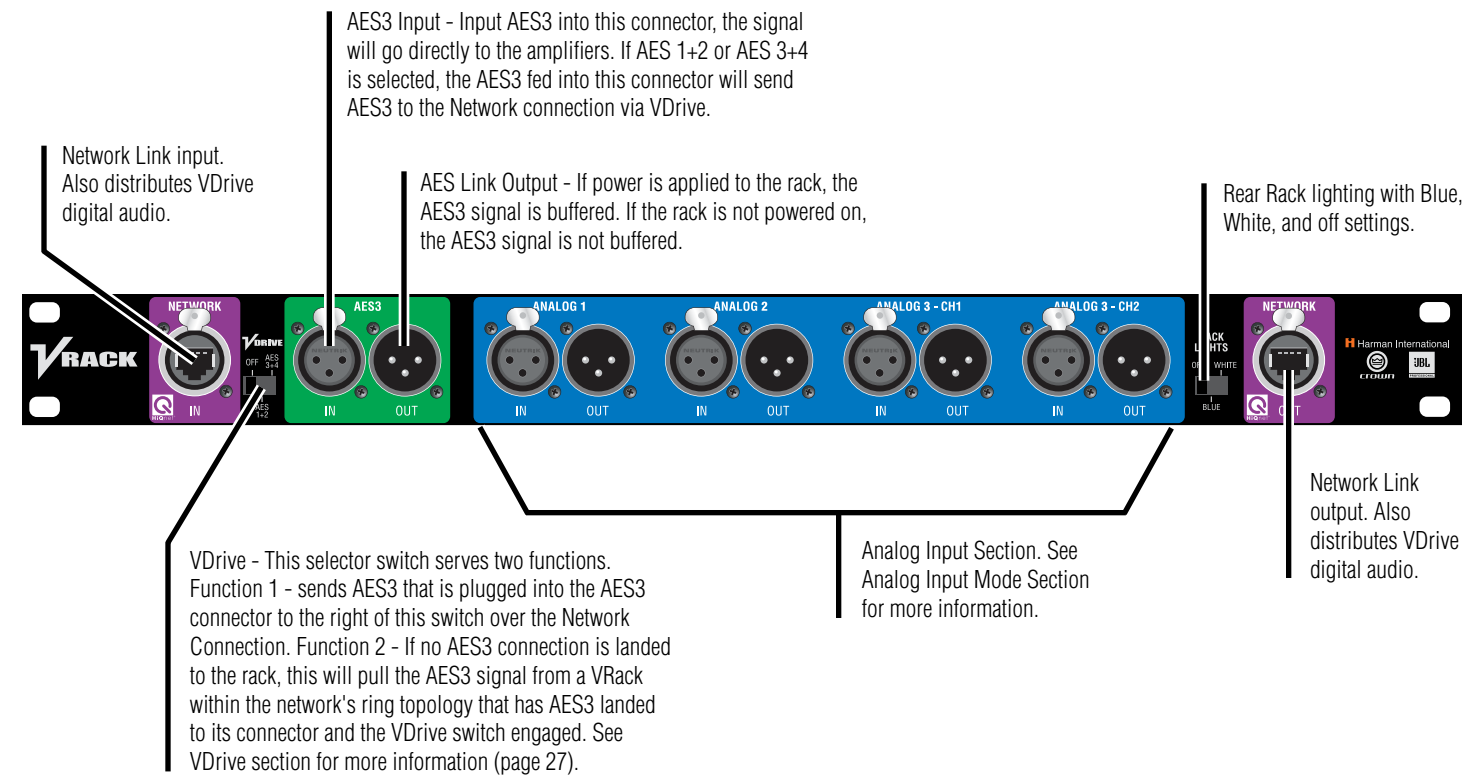

# Analog Input Wiring Schematic

## Analog Input Rack Wiring Schematic

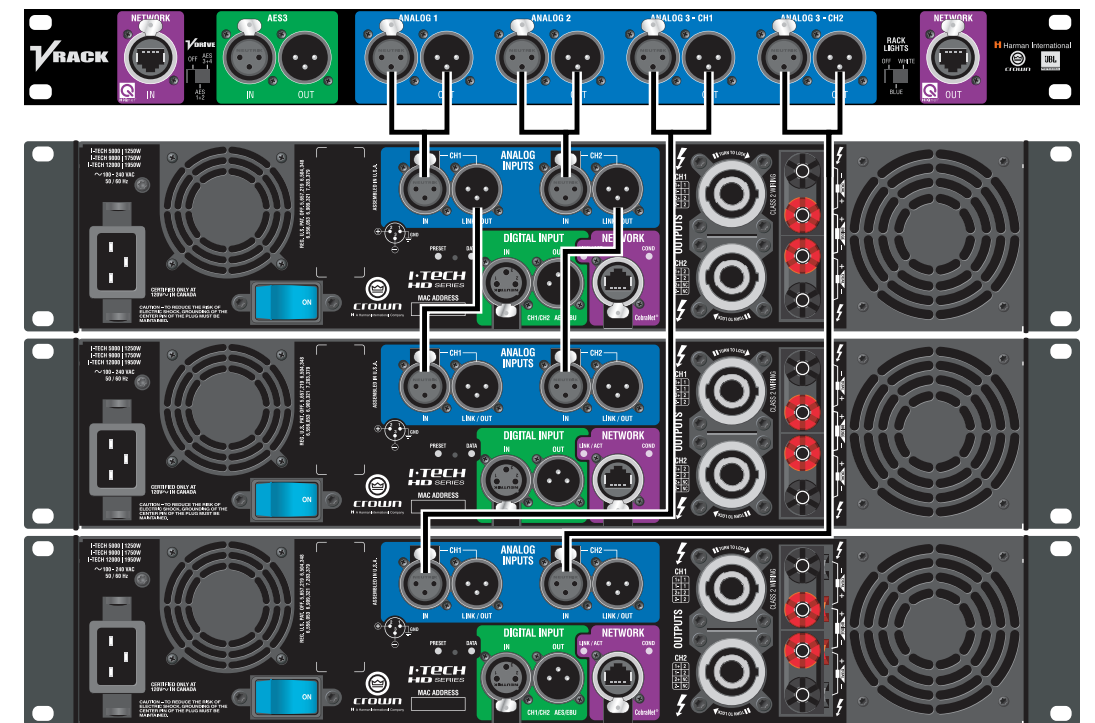



# Input Wiring Modes - Analog

## Mono 1

- MONO 1
- MONO 2
- STEREO
- MONO (1+2)
- 3-MIX
- MONO 1 + AUX
- MONO 2 + AUX

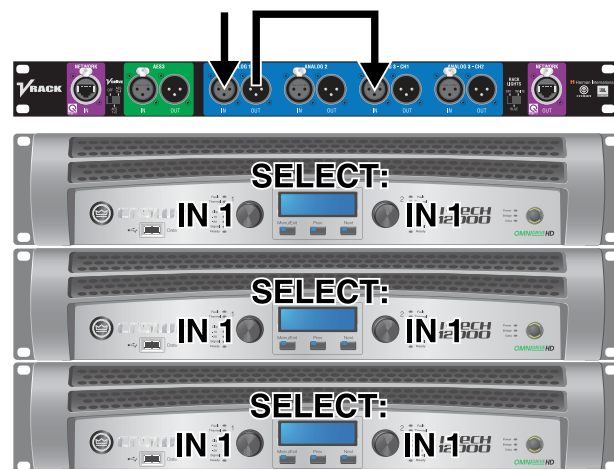

Source Routing  
Channel 1:



Source Routing  
Channel 2:



# Input Wiring Modes - Analog

## Stereo

- MONO 1
- MONO 2
- STEREO
- MONO (1+2)
- 3-MIX
- MONO 1 + AUX
- MONO 2 + AUX

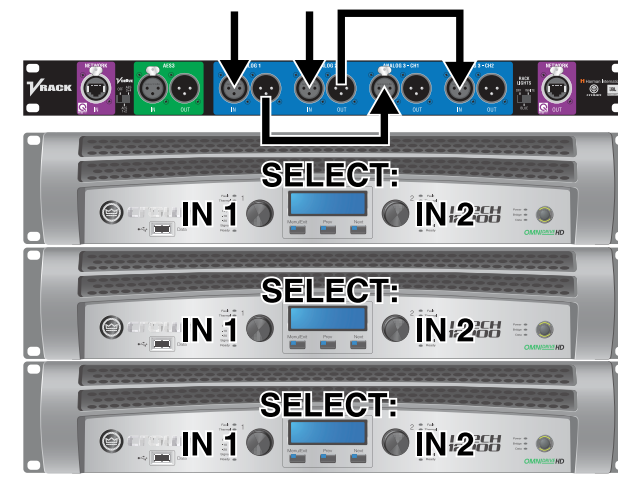

Source Routing  
Channel 1:



Source Routing  
Channel 2:



## Mono 2

- MONO 1
- MONO 2**
- STEREO
- MONO (1+2)
- 3-MIX
- MONO 1 + AUX
- MONO 2 + AUX

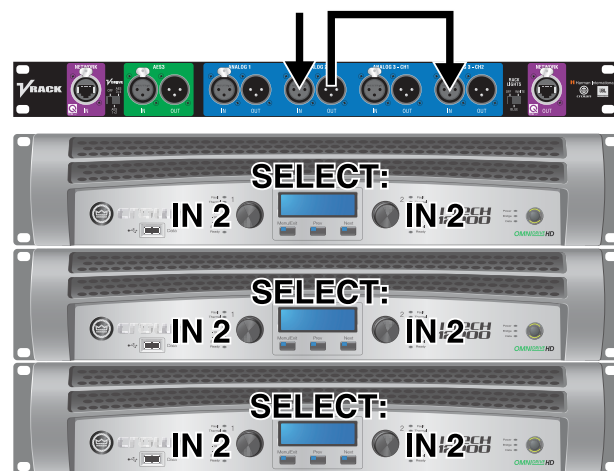

Source Routing  
Channel 1:



Source Routing  
Channel 2:



## Mono (1+2)

- MONO 1
- MONO 2
- STEREO
- MONO (1+2)**
- 3-MIX
- MONO 1 + AUX
- MONO 2 + AUX

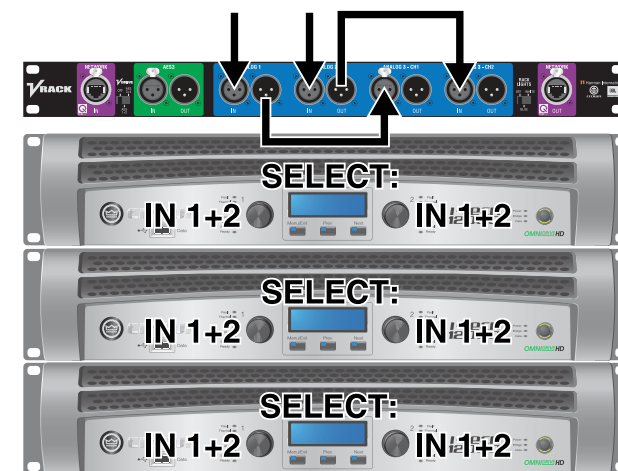

Source Routing  
Channel 1:



Source Routing  
Channel 2:



# Input Wiring Modes - Analog

3-Mix

- MONO 1
- MONO 2
- STEREO
- MONO (1+2)
- 3-MIX**
- MONO 1 + AUX
- MONO 2 + AUX

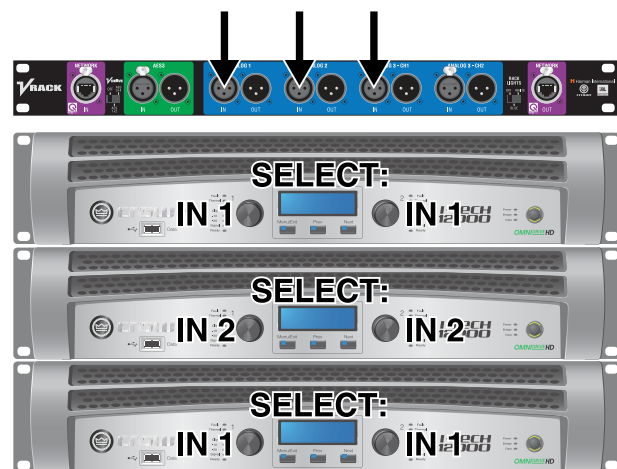

Source Routing  
Channel 1:

ANALOG SOURCE  
IN 1 IN 2 1+2  
CH1

ANALOG SOURCE  
IN 1 IN 2 1+2  
CH1

ANALOG SOURCE  
IN 1 IN 2 1+2  
CH1

Source Routing  
Channel 2:

ANALOG SOURCE  
IN 1 IN 2 1+2  
CH2

ANALOG SOURCE  
IN 1 IN 2 1+2  
CH2

ANALOG SOURCE  
IN 1 IN 2 1+2  
CH2

# Input Wiring Modes - Analog

Mono 2 + Aux

- MONO 1
- MONO 2
- STEREO
- MONO (1+2)
- 3-MIX
- MONO 1 + AUX
- MONO 2 + AUX**

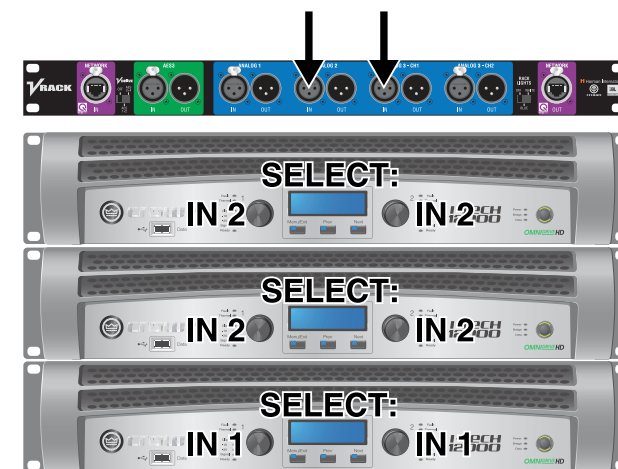

Source Routing  
Channel 1:

ANALOG SOURCE  
IN 1 IN 2 1+2  
CH1

ANALOG SOURCE  
IN 1 IN 2 1+2  
CH1

ANALOG SOURCE  
IN 1 IN 2 1+2  
CH1

Source Routing  
Channel 2:

ANALOG SOURCE  
IN 1 IN 2 1+2  
CH2

ANALOG SOURCE  
IN 1 IN 2 1+2  
CH2

ANALOG SOURCE  
IN 1 IN 2 1+2  
CH2

Mono 1 + Aux

- MONO 1
- MONO 2
- STEREO
- MONO (1+2)
- 3-MIX
- MONO 1 + AUX**
- MONO 2 + AUX

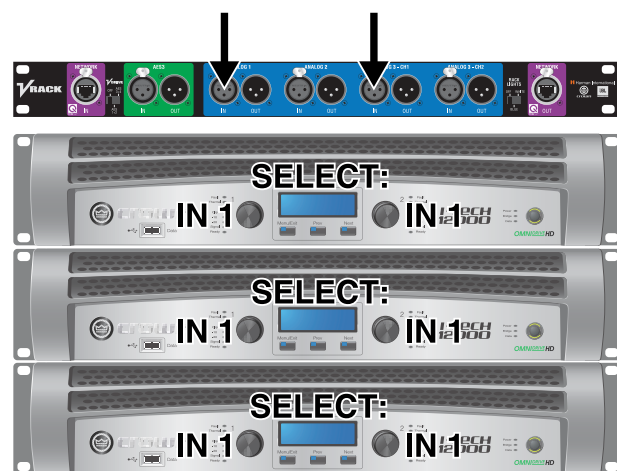

Source Routing  
Channel 1:

ANALOG SOURCE  
IN 1 IN 2 1+2  
CH1

ANALOG SOURCE  
IN 1 IN 2 1+2  
CH1

ANALOG SOURCE  
IN 1 IN 2 1+2  
CH1

Source Routing  
Channel 2:

ANALOG SOURCE  
IN 1 IN 2 1+2  
CH2

ANALOG SOURCE  
IN 1 IN 2 1+2  
CH2

ANALOG SOURCE  
IN 1 IN 2 1+2  
CH2

# Digital Input Wiring Schematic

Digital Input Rack Wiring Schematic

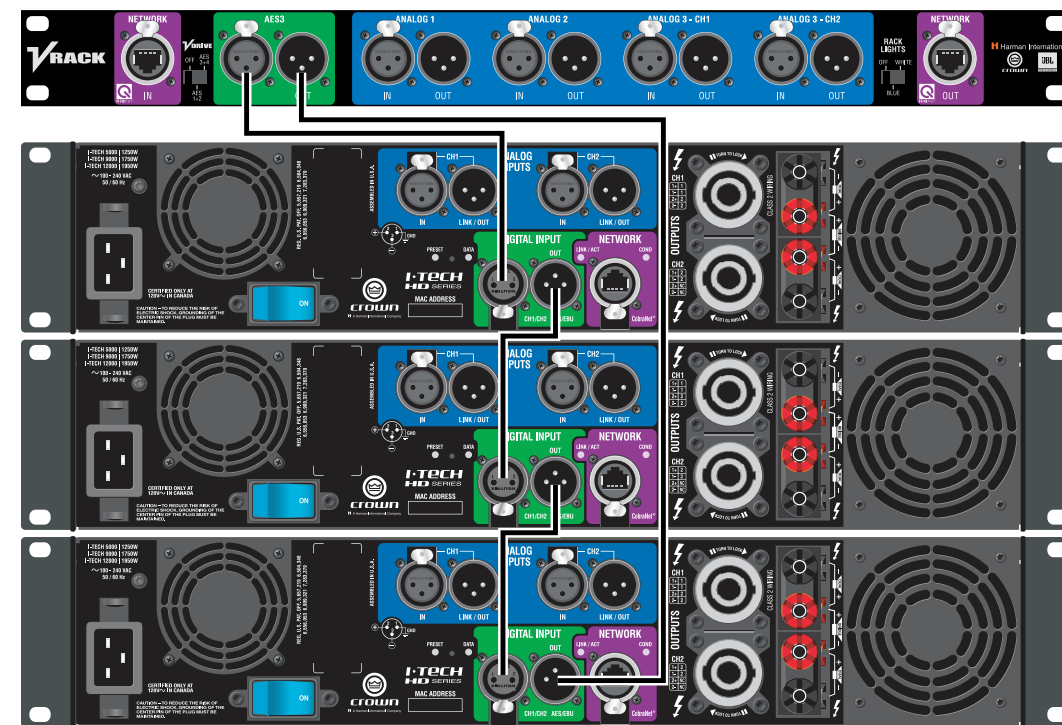

# Input Wiring Modes – Digital

## Mono 1

MONO 1  
MONO 2  
STEREO  
MONO (1+2)

## Mono 2

MONO 1  
MONO 2  
STEREO  
MONO (1+2)

# Input Wiring Modes - Digital

## Stereo

MONO 1  
MONO 2  
STEREO  
MONO (1+2)

## Mono (1+2)

MONO 1  
MONO 2  
STEREO  
MONO (1+2)

# Input Wiring Modes – Hybrid, Digital and Analog

3-Mix

3-MIX  
MONO 1 + AUX  
MONO 2 + AUX

**Source Routing Channel 1:**

**DIGITAL SOURCE**

- AES
- COBRANET
- DIGITAL SOURCE INPUT SELECT
- IN 1 IN 2 1+2
- CH1

**DIGITAL SOURCE**

- AES
- COBRANET
- DIGITAL SOURCE INPUT SELECT
- IN 1 IN 2 1+2
- CH2

**ANALOG SOURCE**

- IN 1
- IN 2
- 1+2
- CH1

**Source Routing Channel 2:**

**DIGITAL SOURCE**

- AES
- COBRANET
- DIGITAL SOURCE INPUT SELECT
- IN 1 IN 2 1+2
- CH2

**DIGITAL SOURCE**

- AES
- COBRANET
- DIGITAL SOURCE INPUT SELECT
- IN 1 IN 2 1+2
- CH2

**ANALOG SOURCE**

- IN 1
- IN 2
- 1+2
- CH2

# Input Wiring Modes – Hybrid, Digital and Analog

AES 2 + Aux

3-MIX  
MONO 1 + AUX  
MONO 2 + AUX  
STEREO + AUX

**Source Routing Channel 1:**

**DIGITAL SOURCE**

- AES
- COBRANET
- DIGITAL SOURCE INPUT SELECT
- IN 1 IN 2 1+2
- CH1

**DIGITAL SOURCE**

- AES
- COBRANET
- DIGITAL SOURCE INPUT SELECT
- IN 1 IN 2 1+2
- CH1

**ANALOG SOURCE**

- IN 1
- IN 2
- 1+2
- CH1

**Source Routing Channel 2:**

**DIGITAL SOURCE**

- AES
- COBRANET
- DIGITAL SOURCE INPUT SELECT
- IN 1 IN 2 1+2
- CH2

**DIGITAL SOURCE**

- AES
- COBRANET
- DIGITAL SOURCE INPUT SELECT
- IN 1 IN 2 1+2
- CH2

**ANALOG SOURCE**

- IN 1
- IN 2
- 1+2
- CH2

AES 1 + Aux

3-MIX  
MONO 1 + AUX  
MONO 2 + AUX  
STEREO + AUX

**Source Routing Channel 1:**

**DIGITAL SOURCE**

- AES
- COBRANET
- DIGITAL SOURCE INPUT SELECT
- IN 1 IN 2 1+2
- CH1

**DIGITAL SOURCE**

- AES
- COBRANET
- DIGITAL SOURCE INPUT SELECT
- IN 1 IN 2 1+2
- CH1

**ANALOG SOURCE**

- IN 1
- IN 2
- 1+2
- CH1

**Source Routing Channel 2:**

**DIGITAL SOURCE**

- AES
- COBRANET
- DIGITAL SOURCE INPUT SELECT
- IN 1 IN 2 1+2
- CH2

**DIGITAL SOURCE**

- AES
- COBRANET
- DIGITAL SOURCE INPUT SELECT
- IN 1 IN 2 1+2
- CH2

**ANALOG SOURCE**

- IN 1
- IN 2
- 1+2
- CH2

AES1 + AES2 + Aux

3-MIX  
MONO 1 + AUX  
MONO 2 + AUX  
STEREO + AUX

**Source Routing Channel 1:**

**DIGITAL SOURCE**

- AES
- COBRANET
- DIGITAL SOURCE INPUT SELECT
- IN 1 IN 2 1+2
- CH1

**DIGITAL SOURCE**

- AES
- COBRANET
- DIGITAL SOURCE INPUT SELECT
- IN 1 IN 2 1+2
- CH1

**ANALOG SOURCE**

- IN 1
- IN 2
- 1+2
- CH1

**Source Routing Channel 2:**

**DIGITAL SOURCE**

- AES
- COBRANET
- DIGITAL SOURCE INPUT SELECT
- IN 1 IN 2 1+2
- CH2

**DIGITAL SOURCE**

- AES
- COBRANET
- DIGITAL SOURCE INPUT SELECT
- IN 1 IN 2 1+2
- CH2

**ANALOG SOURCE**

- IN 1
- IN 2
- 1+2
- CH2

# Network Wiring Schematic

Network Input Rack Wiring Schematic

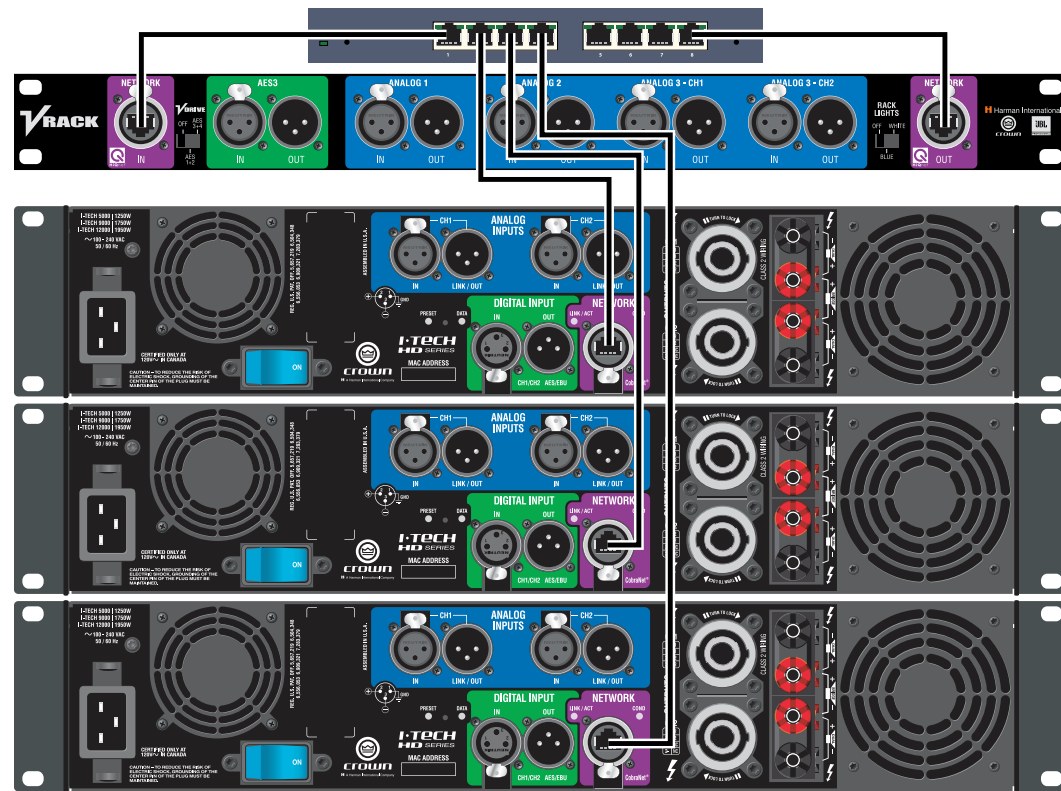

Network Switch info:



ProSafe® 8-Port Gigabit Smart Switch (GS108T)

## VDrive

VDrive Wiring Schematic

RJ45 Pin #	Wire Color (T568A)	Wire Diagram (T568A)	10Base-T Signal 100Base-TX Signal	1000Base-T Signal
1	White/Green		Transmit +	BI_DA+
2	Green		Transmit -	BI_DA-
3	White/Orange		Receive +	BI_DB+
4	Blue		AES 1/2 +	BI_DC+
5	White/Blue		AES 1/2 -	BI_DC-
6	Orange		Receive -	BI_DB-
7	White/Brown		AES 3/4 +	BI_DD+
8	Brown		AES 3/4 -	BI_DD-

## VDrive

VDrive is a digital AES3 transport mechanism that combines a standard 10/100MB network connection with AES3 signals. VDrive employs the unused pins of a 10/100MB network to transport AES3 digital audio signals. As indicated in the chart above, one is able to transmit 4 channels of digital audio using a standard CAT5 cable.

The idea behind VDrive is to connect your VRacks in a ring topology, feed AES3 into the first rack and select the switch of which AES3 stream (1/2 or 3/4) to send via the CAT5 connection to subsequent VRacks in the network ring. On the VRacks after the first rack, simply select the desired AES stream via the VDrive switch (SEE THE FOLLOWING DIAGRAMS).

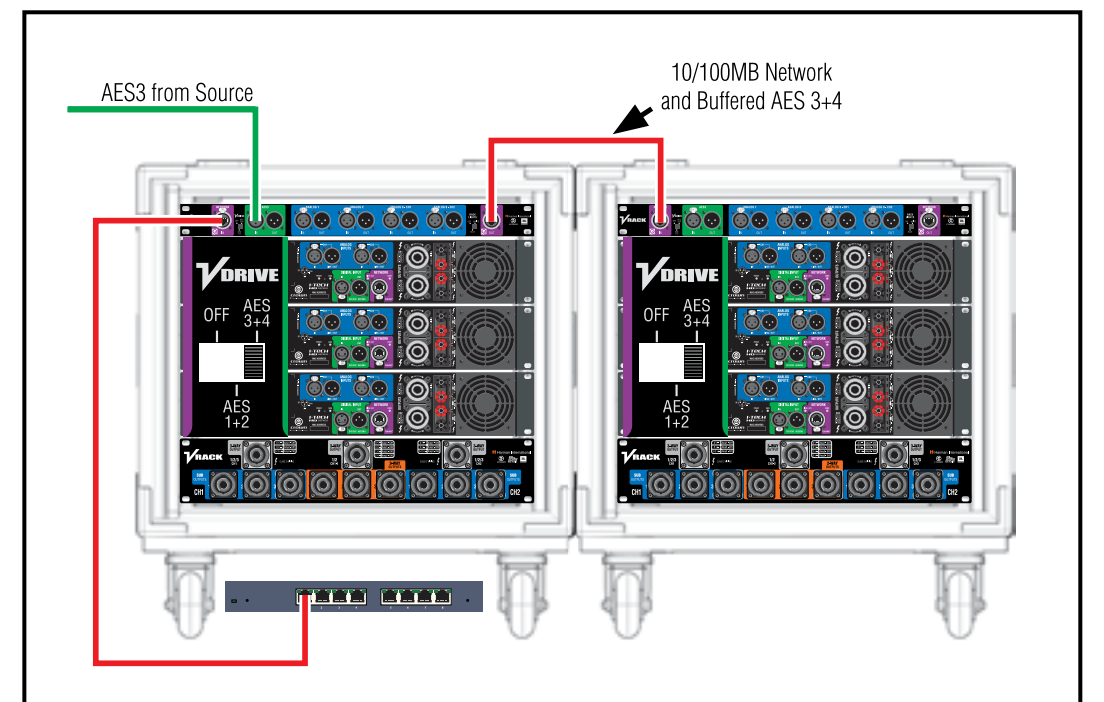
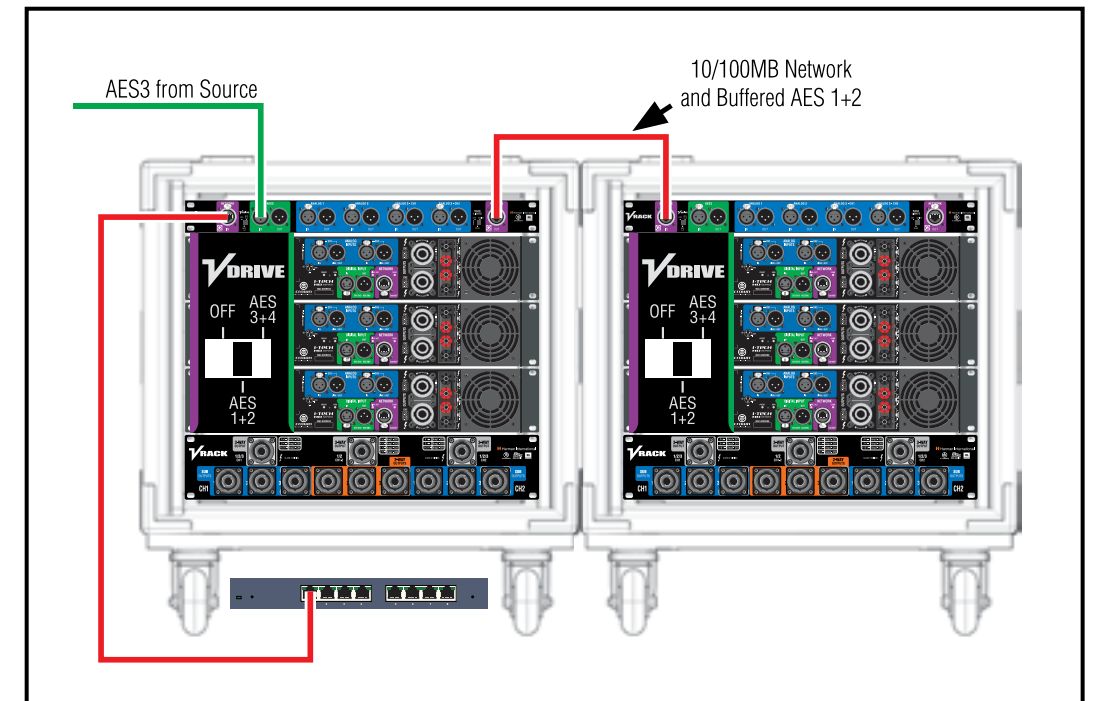

# Output Panel

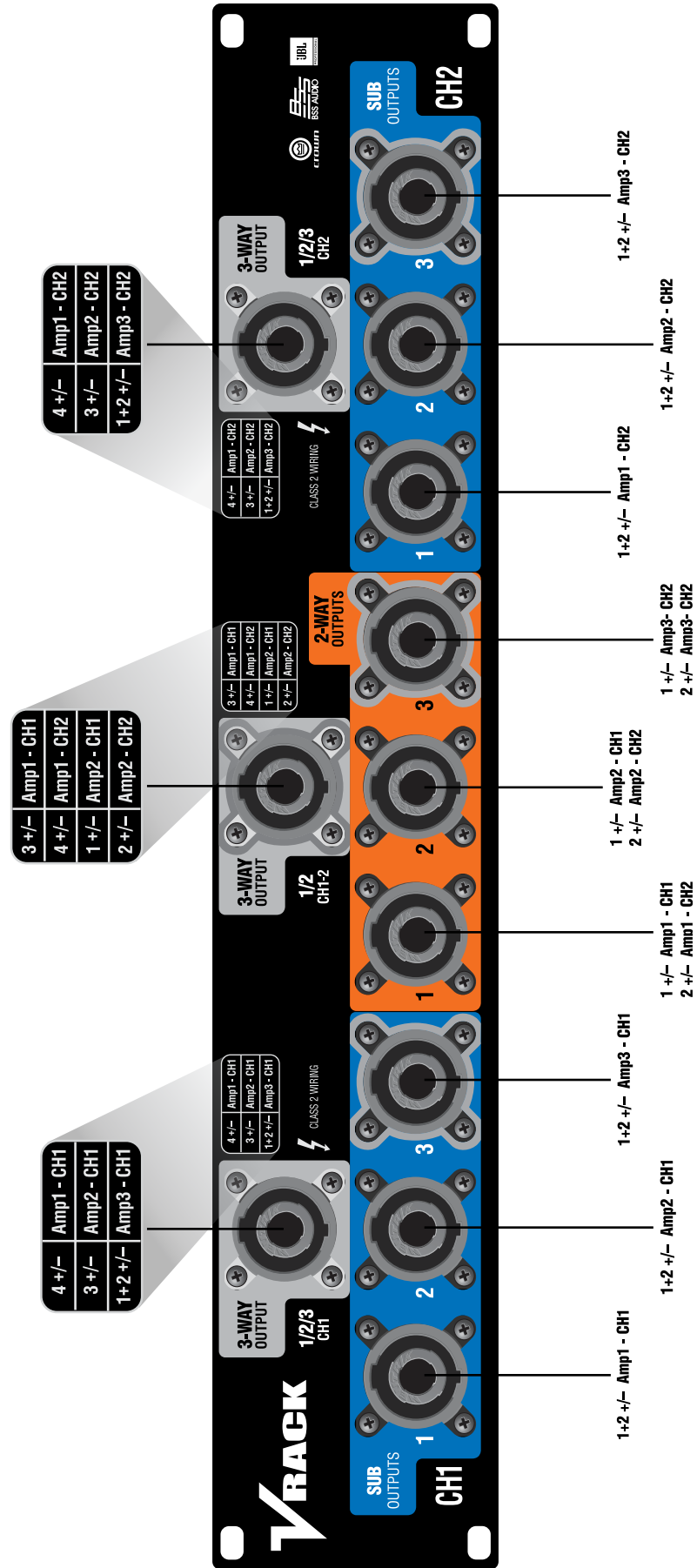

NOTE: Each subwoofer output is wired with the conductors in parallel: 1+2+ and 1-2-  
 NOTE: Center NL8 connector (1/2 ch.1-2) LF sections are wired discretely. Max: 4x4889, 4x4888 (2ohm LF section load). Rec'd: 3x4889, 3x4888 (2.7ohm LF section load).  
 NOTE: Outside NL8 connectors (1/2/3 ch.1 & 1/2/3 ch.2) have pins 3+/- and 4+/- wired in parallel. When using these connectors, max 2x4889 or 2x4888 (2ohm LF section load).

# Output Wiring Modes

JBL and Crown have established this set of recommended circuiting configurations for all VerTec/iTechHD systems worldwide. Please follow these good/better/best guidelines in order to ensure optimum system performance.

## High Performance

A High Performance (HP) system has the following characteristics:

- 1:1 Ratio of Tops to Subs
- NO sub or LF section loads below 4ohms
- 2 cabinets per circuit for optimal array shading and tapering resolution
- Best possible power match to iTechHD amplifiers, with most systemwide headroom for loud concerts and highly dynamic content.

## Nominal

A Nominal (Nom) system has the following characteristics:

- 3:2 Ratio of Tops to Subs
- Some driver loads at 2.7ohms
- 3 cabinets per circuit for good match between power handling and array shading and tapering resolution
- Appropriate power match for iTechHD amplifiers, good balance between systemwide headroom and increased array coverage

## Economy Power

An Economy Power (Econ) system has the following characteristics:

- 2:1 Ratio of Tops to Subs, or no subs
- Some driver loads at 2ohms
- Using 3-Way+3-Way mode which powers lows at 2ohms on a circuit of 2 x VT4889 or VT4888
- Economy mode is appropriate for speech or music reinforcement with limited SPL requirements.

# Output Wiring Modes

## 3-Way + 3-Way Mode

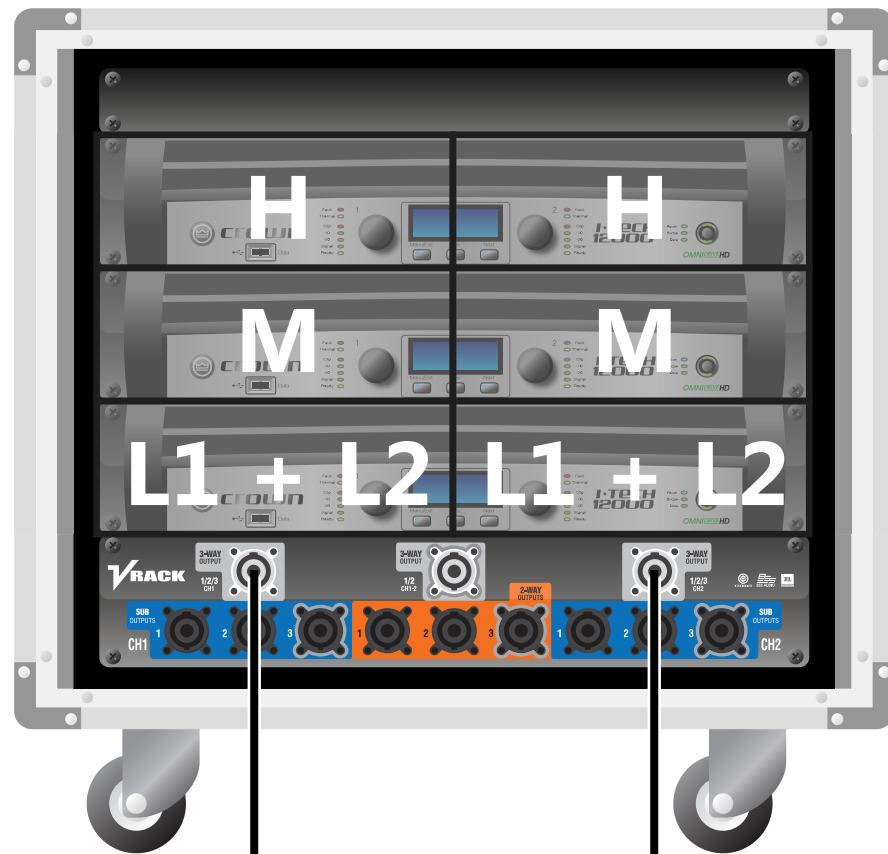

	HP	Nom	Econ	Max
VT4889	1	1	2	2
VT4888	1	1	2	2
VTX V25	1	1	2	2

	HP	Nom	Econ	Max
VT4889	1	1	2	2
VT4888	1	1	2	2
VTX V25	1	1	2	2

# Output Wiring Modes

## 3-Way + Sub Mode

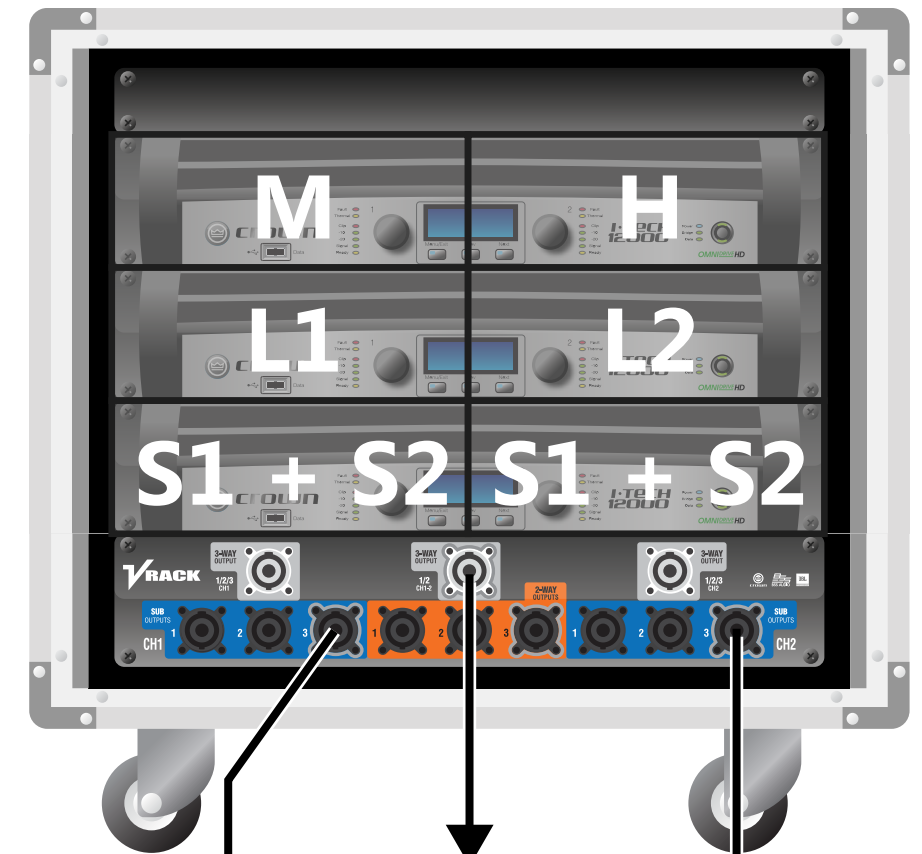

	HP	Nom	Econ	Max
VT4889	2	3	4	4
VT4888	2	3	4	4
VTX V25	2	3	4	4

	HP	Nom	Econ	Max
VT4880A	1	1	1	1
VT4880	1	1	2	2
VT4881A	2	2	3	3
VT4882	1	1	2	2
VT4883	1	1	2	2
VTX S28	1	1	2	2
VTX G28	1	1	2	2

	HP	Nom	Econ	Max
VT4880A	1	1	1	1
VT4880	1	1	2	2
VT4881A	2	2	3	3
VT4882	1	1	2	2
VT4883	1	1	2	2
VTX S28	1	1	2	2
VTX G28	1	1	2	2

# Output Wiring Modes

## 3-Way + 2-Way Mode

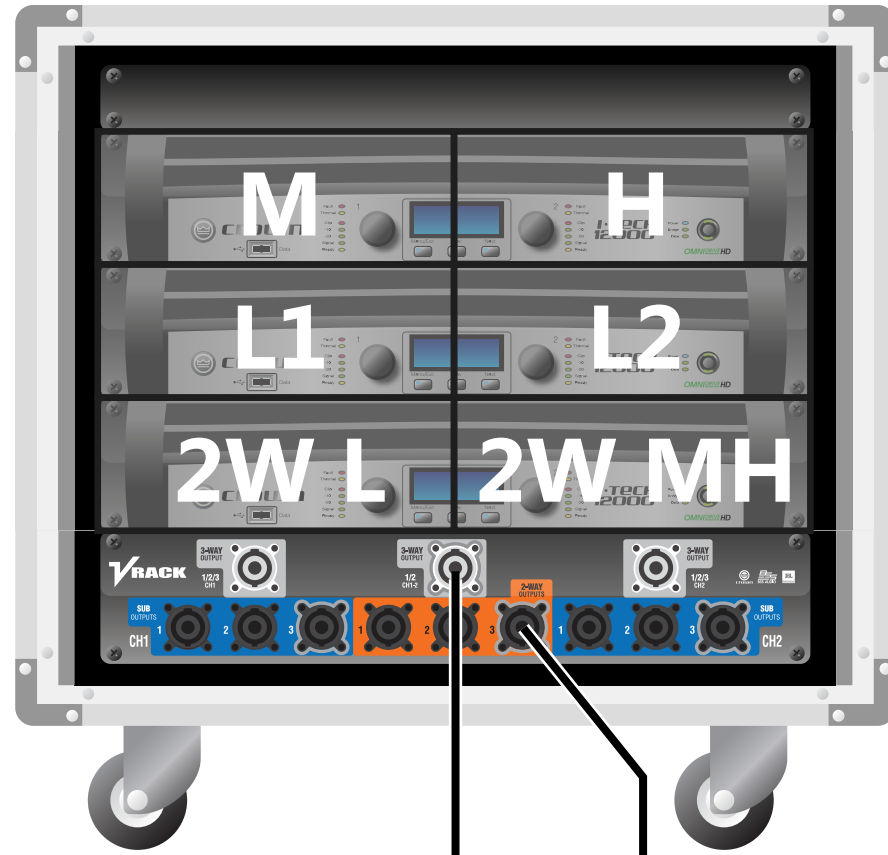

	HP	Nom	Econ	Max
VT4889	2	3	4	4
VT4888	2	3	4	4
VTX V25	2	3	4	4

	HP	Nom	Econ	Max
VT4887A	2	3	4	4
VT4887	2	3	4	4

# Output Wiring Modes

## 3-Way + Passive

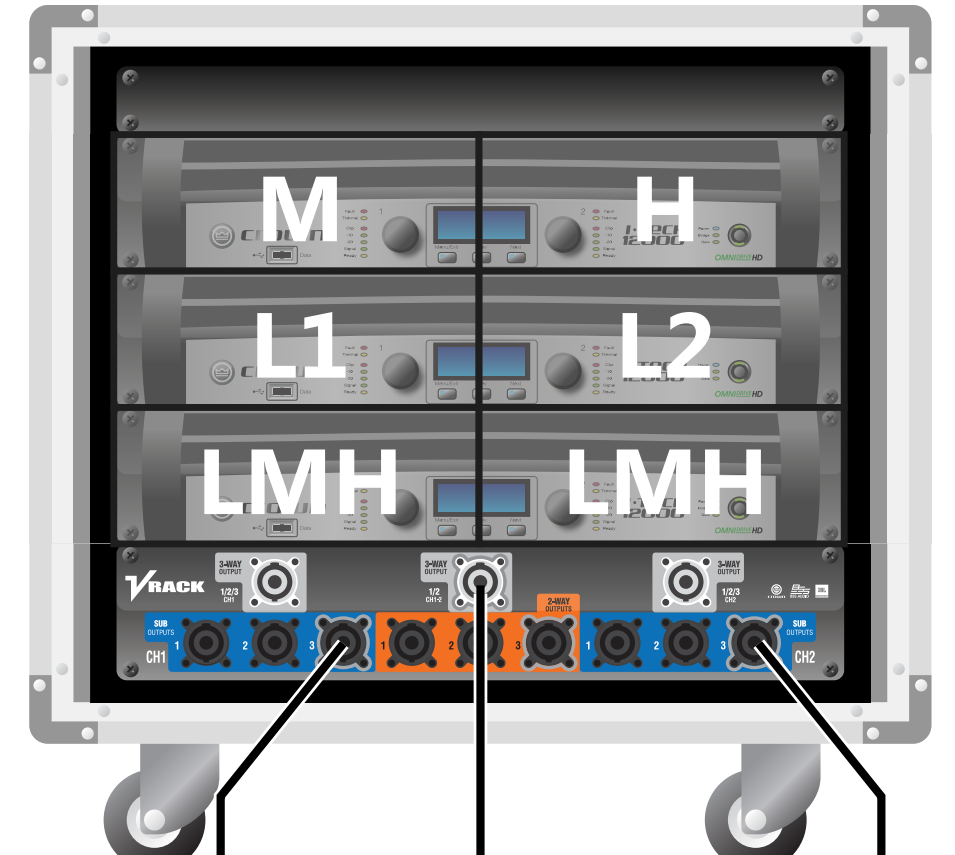

	HP	Nom	Econ	Max
VT4889	2	3	4	4
VT4888	2	3	4	4
VTX V25	2	3	4	4

	HP	Nom	Econ	Max
VT4886	2	3	4	6

	HP	Nom	Econ	Max
VT4886	2	3	4	6



# Output Wiring Modes

Sub Mode

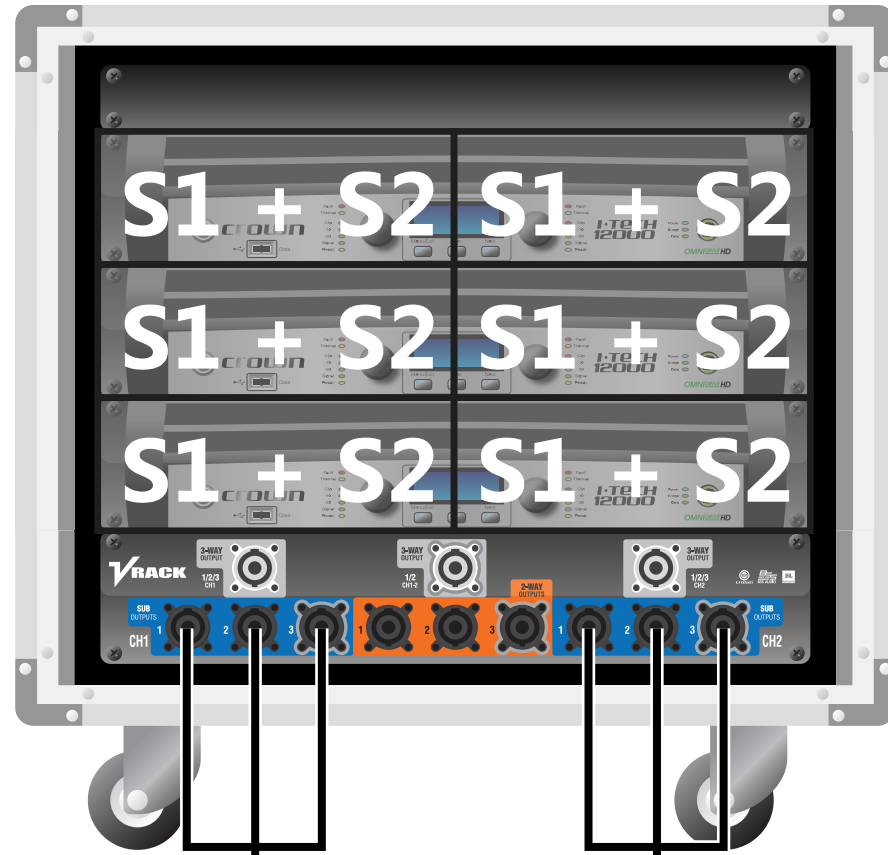

	HP	Nom	Econ	Max
VT4880A	1	1	1	1
VT4880	1	1	2	2
VT4881A	2	2	3	3
VT4882	1	1	2	2
VT4883	1	1	2	2
VTX S28	1	1	2	2
VTX G28	1	1	2	2

(Each output)

	HP	Nom	Econ	Max
VT4880A	1	1	1	1
VT4880	1	1	2	2
VT4881A	2	2	3	3
VT4882	1	1	2	2
VT4883	1	1	2	2
VTX S28	1	1	2	2
VTX G28	1	1	2	2

(Each output)

# Output Wiring Modes

Sub + 3-Way Mode

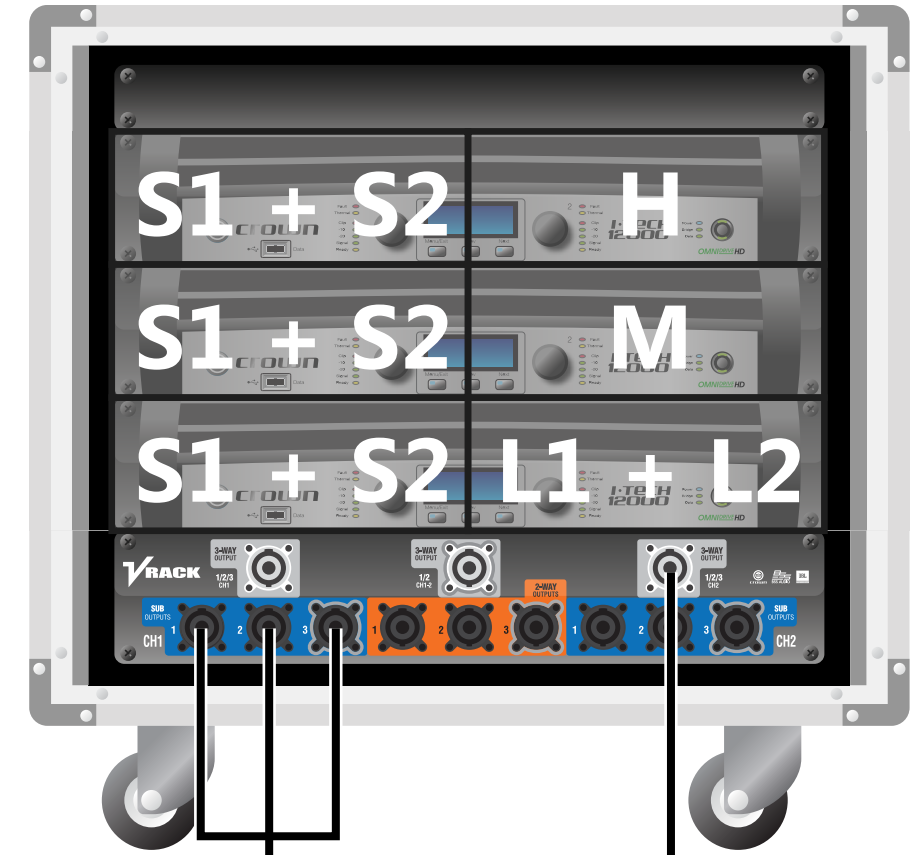

	HP	Nom	Econ	Max
VT4880A	1	1	1	1
VT4880	1	1	2	2
VT4881A	2	2	3	3
VT4882	1	1	2	2
VT4883	1	1	2	2
VTX S28	1	1	2	2
VTX G28	1	1	2	2

(Each output)

	HP	Nom	Econ	Max
VT4889	1	1	2	2
VT4888	1	1	2	2
VTX V25	1	1	2	2

# Output Wiring Modes

## 2-Way Mode

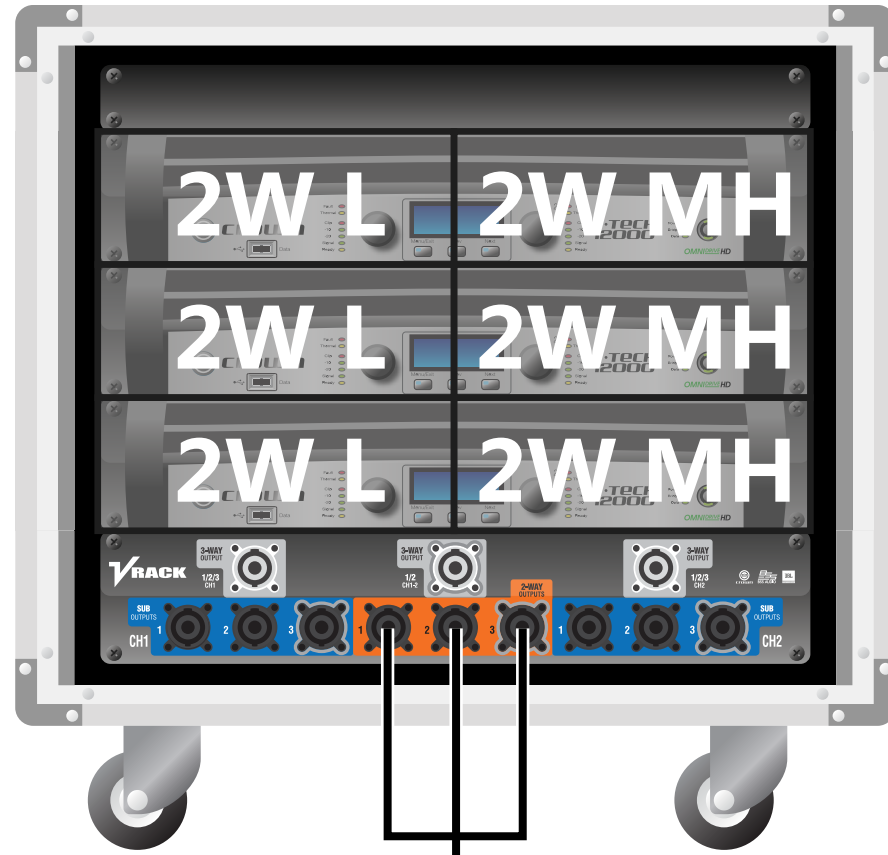

	HP	Nom	Econ	Max
VT4887A	2	3	4	4
VT4887	2	3	4	4

(Each output)

# Output Wiring Modes

## 2-Way + Sub Mode 1

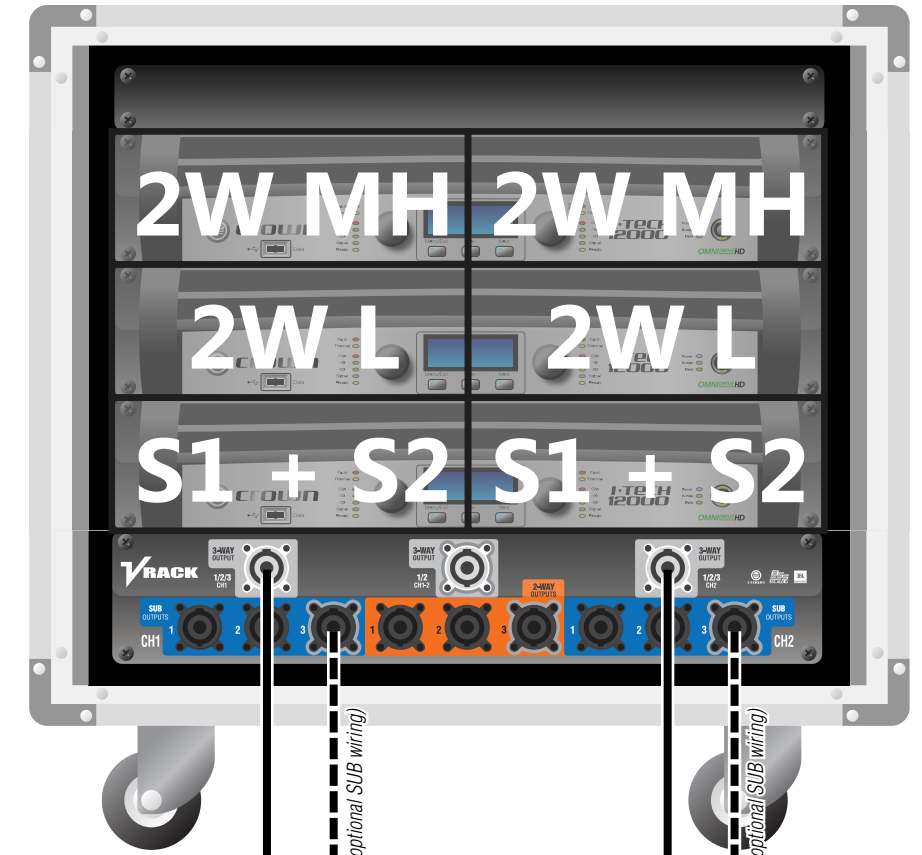

	HP	Nom	Econ	Max
VT4887A	2	3	4	4
VT4887	2	3	4	4
VT4880A	1	1	1	1
VT4880	1	1	2	2
VT4881A	2	2	3	3
VT4882	1	1	2	2
VT4883	1	1	2	2
VTX S28	1	1	2	2
VTX G28	1	1	2	2

(Each output)

	HP	Nom	Econ	Max
VT4887A	2	3	4	4
VT4887	2	3	4	4
VT4880A	1	1	1	1
VT4880	1	1	2	2
VT4881A	2	2	3	3
VT4882	1	1	2	2
VT4883	1	1	2	2
VTX S28	1	1	2	2
VTX G28	1	1	2	2

(Each output)

# Output Wiring Modes

2-Way + Subs Mode 2

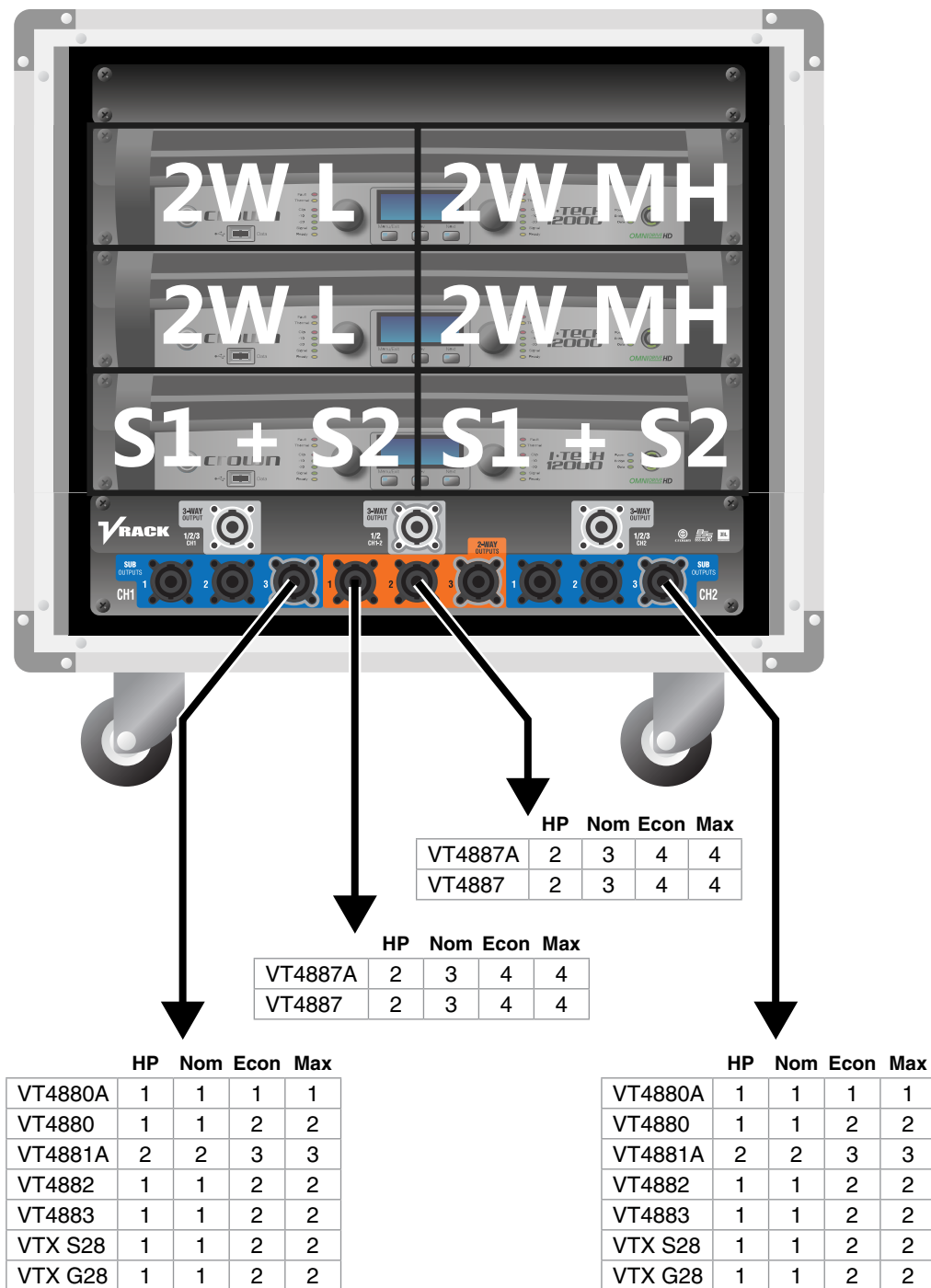

# Output Wiring Modes

Passive Mode

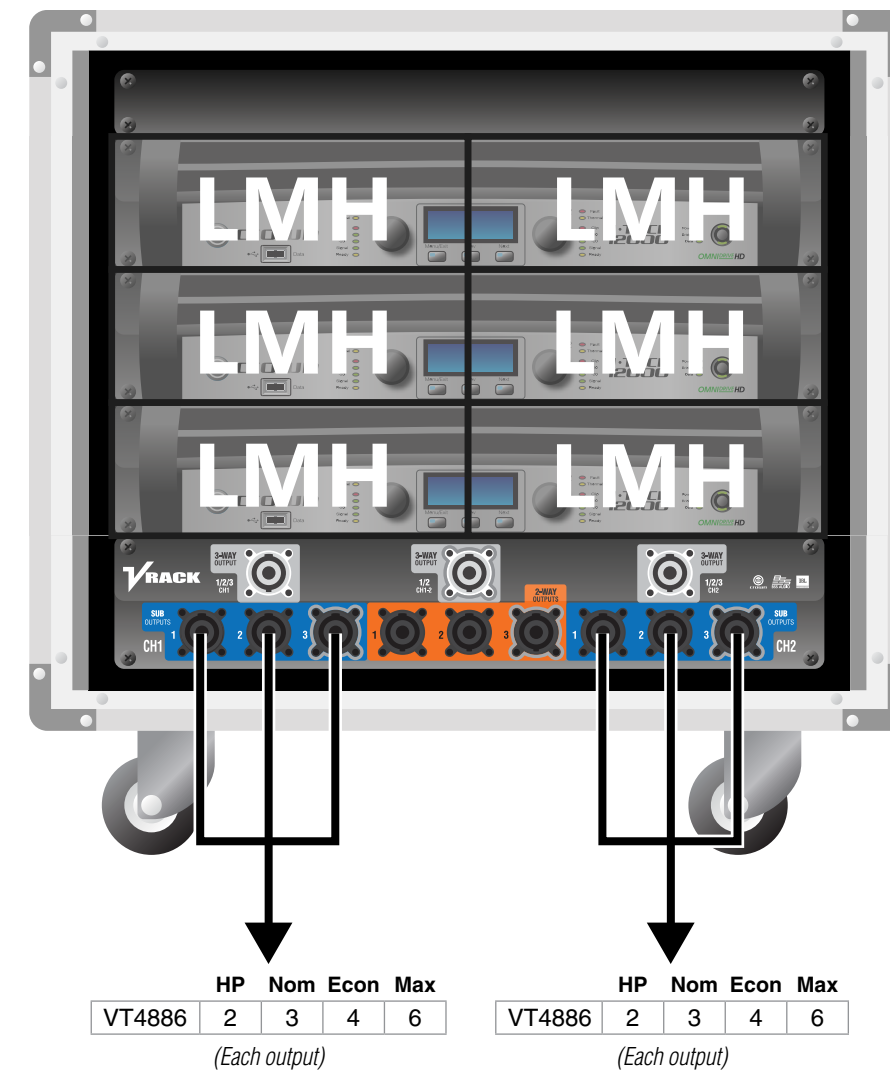

# Output Wiring Modes

Passive + Sub Mode 1

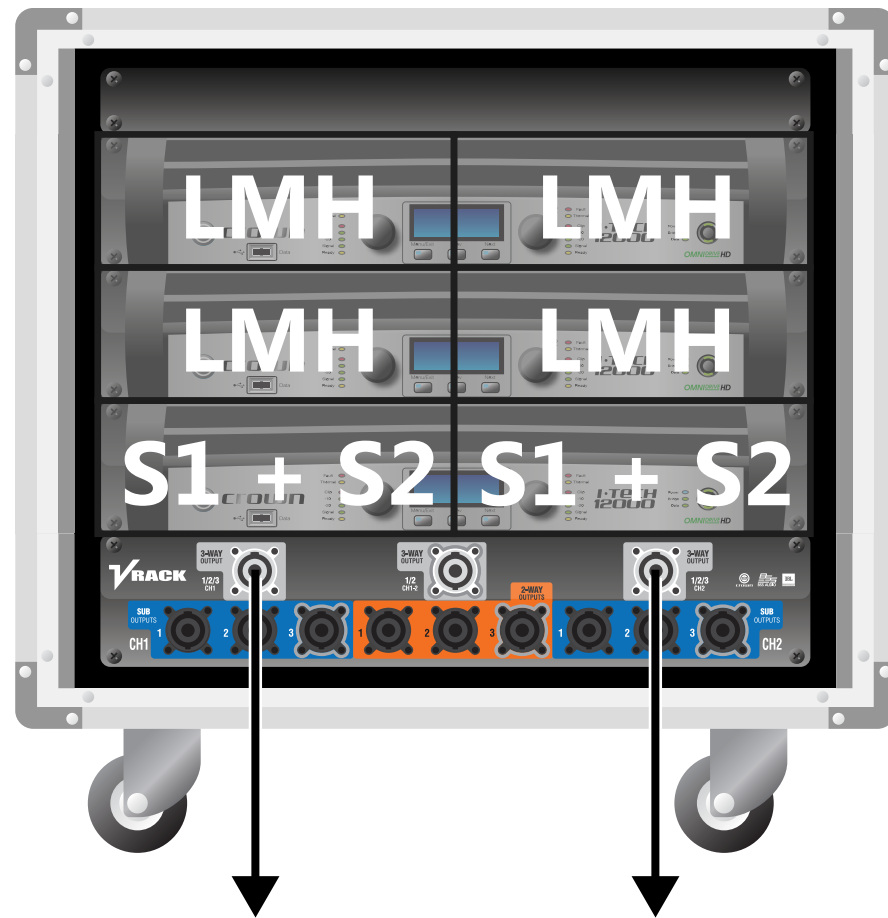

	HP	Nom	Econ	Max
VT4886-A switch	2	3	4	6
VT4886-B switch	2	3	4	6
VT4883	1	1	2	2

	HP	Nom	Econ	Max
VT4886-A switch	2	3	4	6
VT4886-B switch	2	3	4	6
VT4883	1	1	2	2

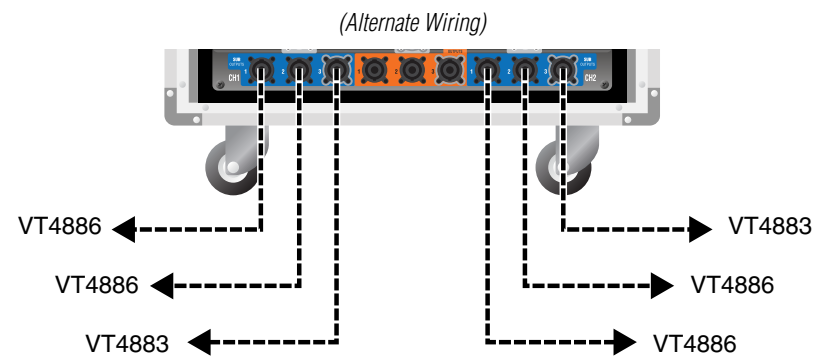

# Output Wiring Modes

Sub + Passive Mode 2

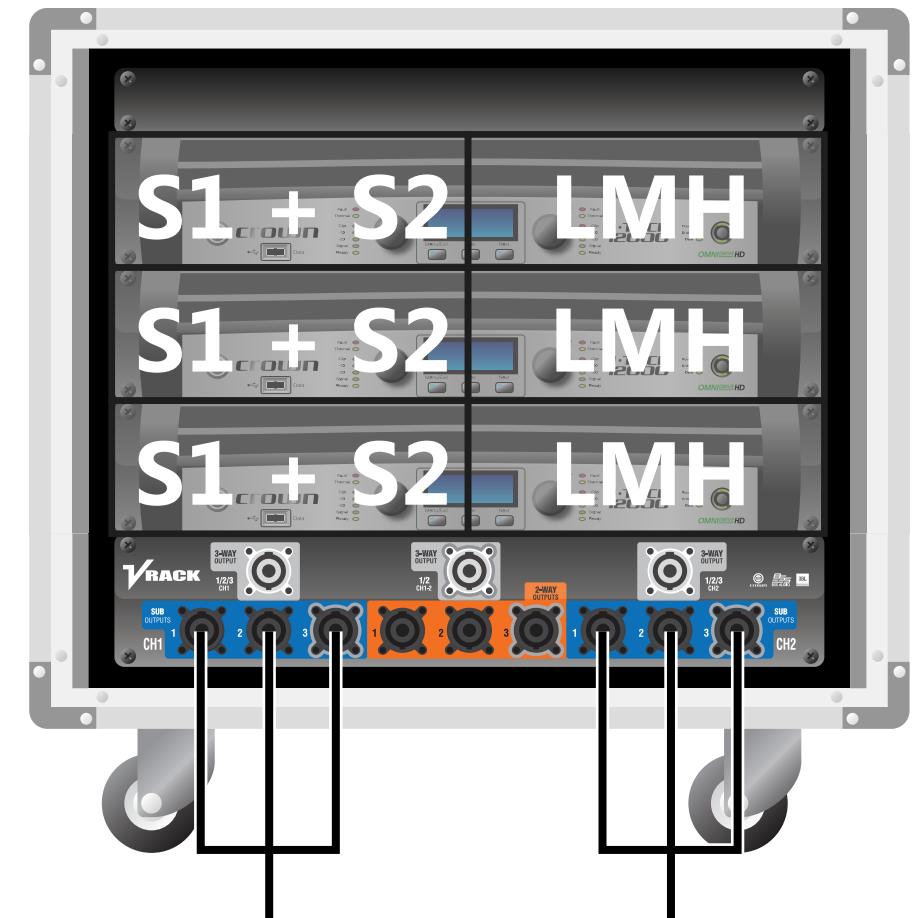

	HP	Nom	Econ	Max
VT4880A	1	1	1	1
VT4880	1	1	2	2
VT4881A	1	2	3	3
VT4882	1	1	2	2
VT4883	1	1	2	2
VTX S28	1	1	2	2
VTX G28	1	1	2	2

(Each output)

	HP	Nom	Econ	Max
VT4886	2	3	4	6

(Each output)

# Output Wiring Modes

## Passive + Sub Mode 3

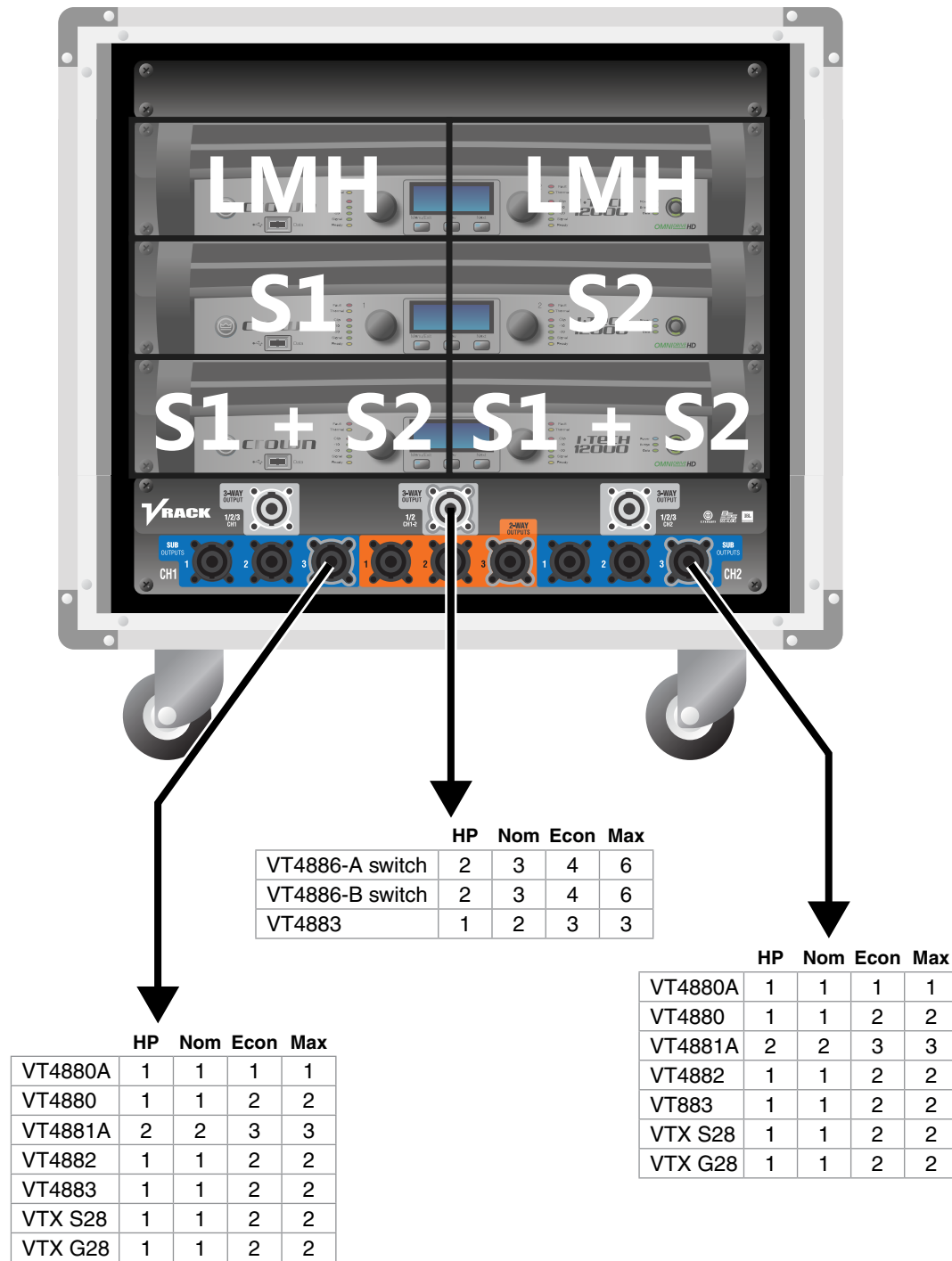

# HiQnet™ Software

The Crown VRack has a unique advantage when used with Harman's HiQnet System Architect software. The software is able to literally 'see' that your iTechHD12000 amplifiers are in a rack, and specifically they're in a VRack. You get specific advantages in speeding up deployment, programming, tuning, and monitoring of a VRack powered system.

In addition, the user can combine the presets in all 3 VRack amplifiers into a single 'VRack Preset'. This is done by loading the individual preset into each amplifier, and then using the VRack control panels 'Preset' tab to save each individual preset into the same preset memory location on each amp. Now with a single click, an 'entire rack' setting can be recalled. For most sound companies this means that with an initial investment of some time in the shop, single-click 'entire rack' settings can be configured for most of the PA in inventory, eliminating the need to program and recall individual presets in the field.

See page 42 for details.

# HiQnet™ Software

## Preset Tab

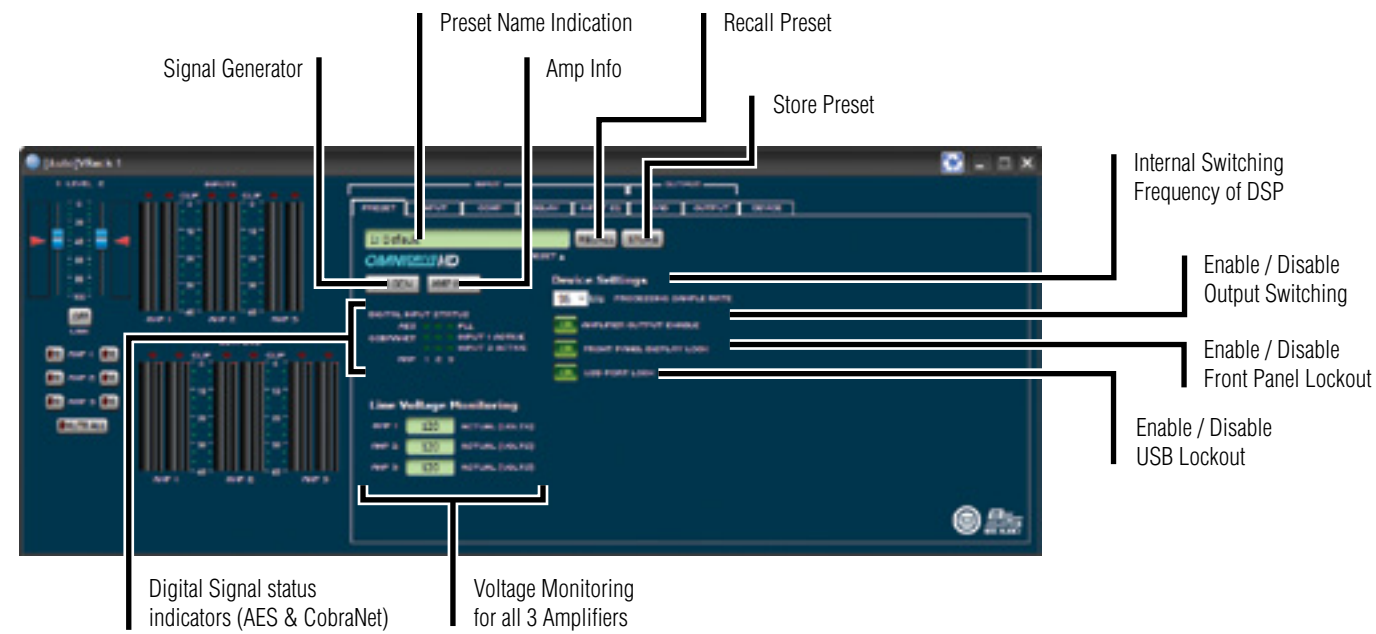

## Monitoring, Mutes, and Attenuation

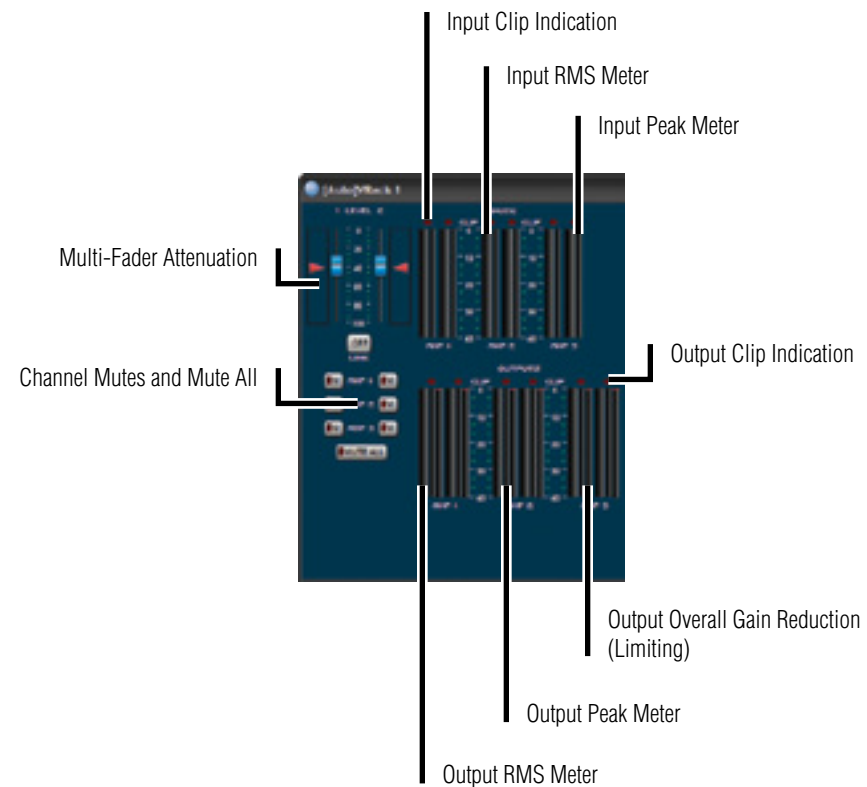

# HiQnet™ Software

## Input Tab

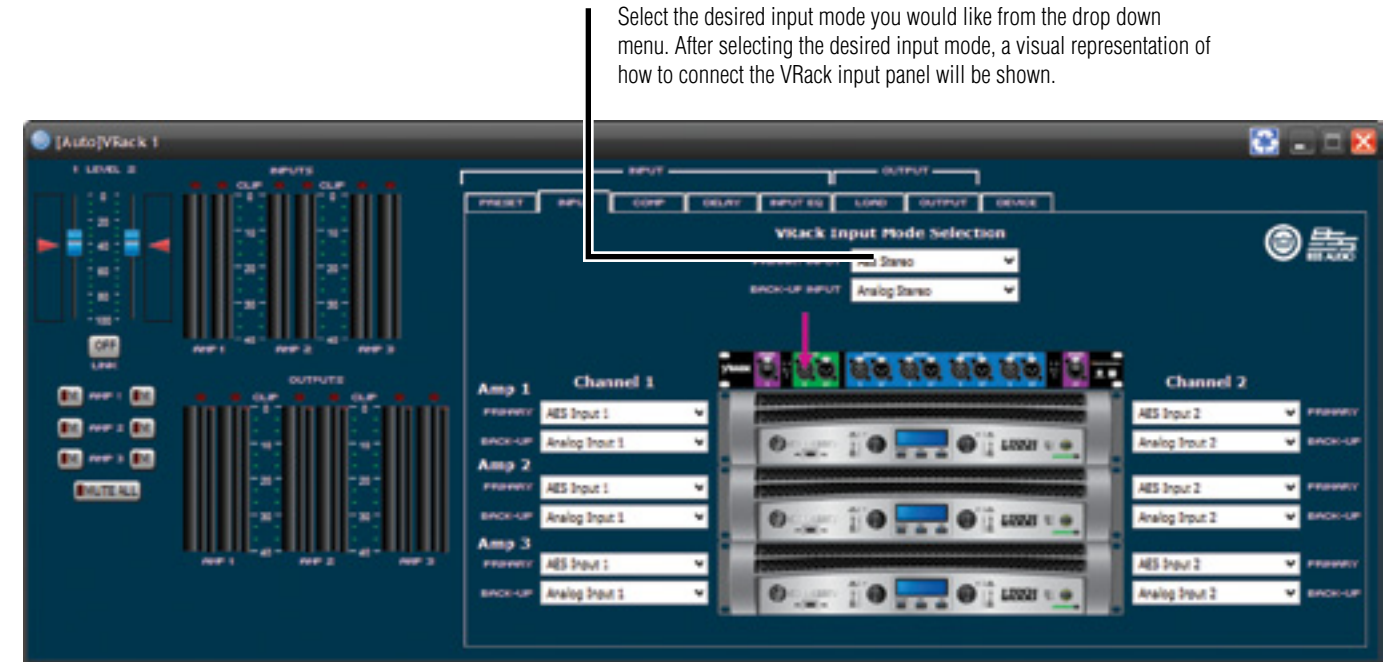

## Compressor Tab

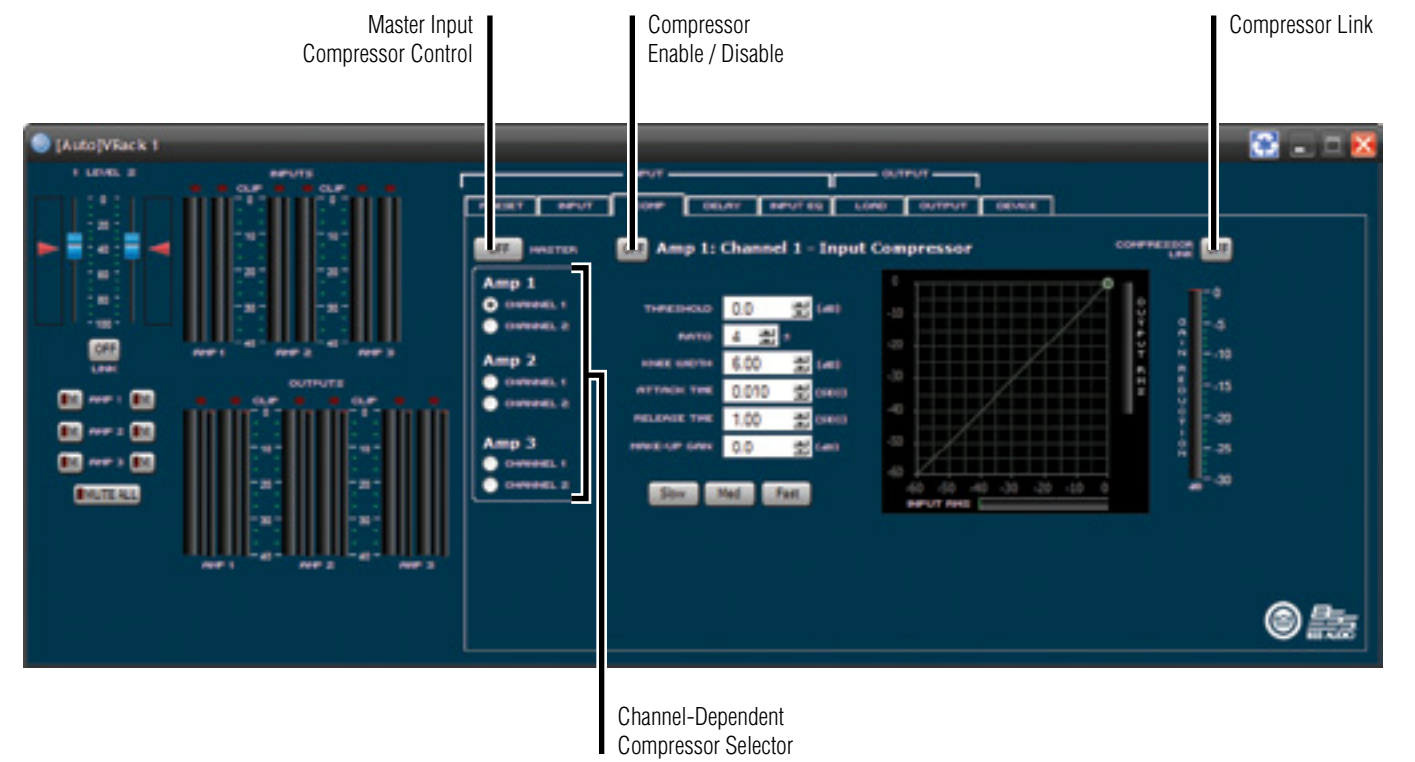

# HiQnet™ Software

## Delay Tab

Channel-Specific Input Delay in Feet, Meters, and Seconds

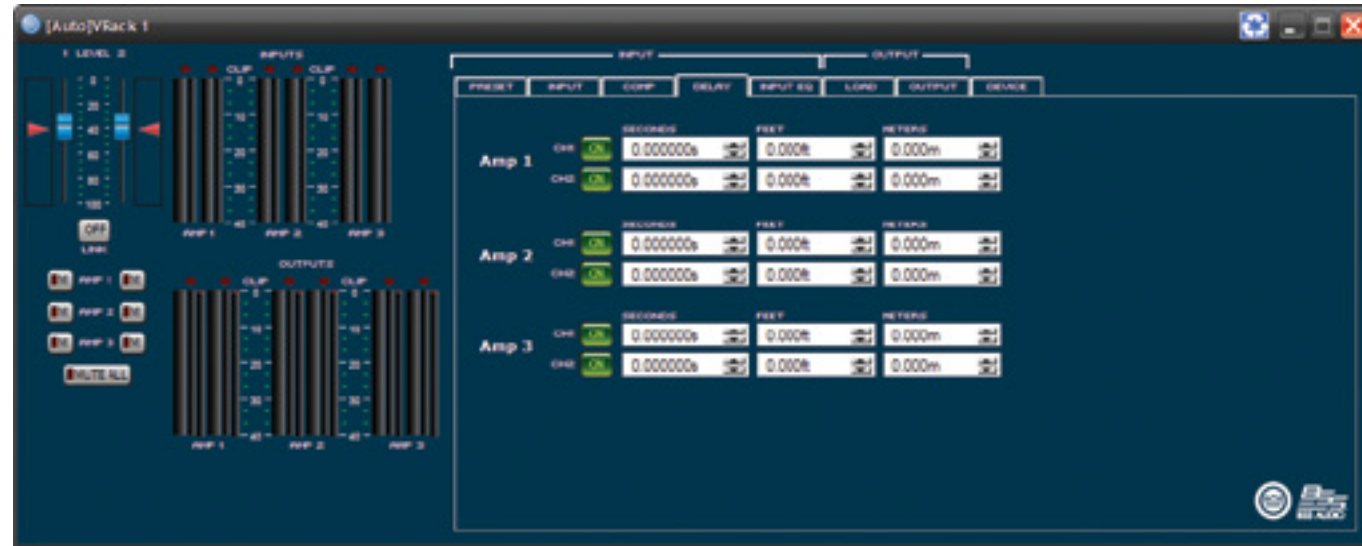

## Input EQ Tab

VRack Input EQ (affects all amps in the rack)  
Types available: Parametric, LP shelf, HP shelf, LP/HP Butterworth, LP/HP EQ, All pass

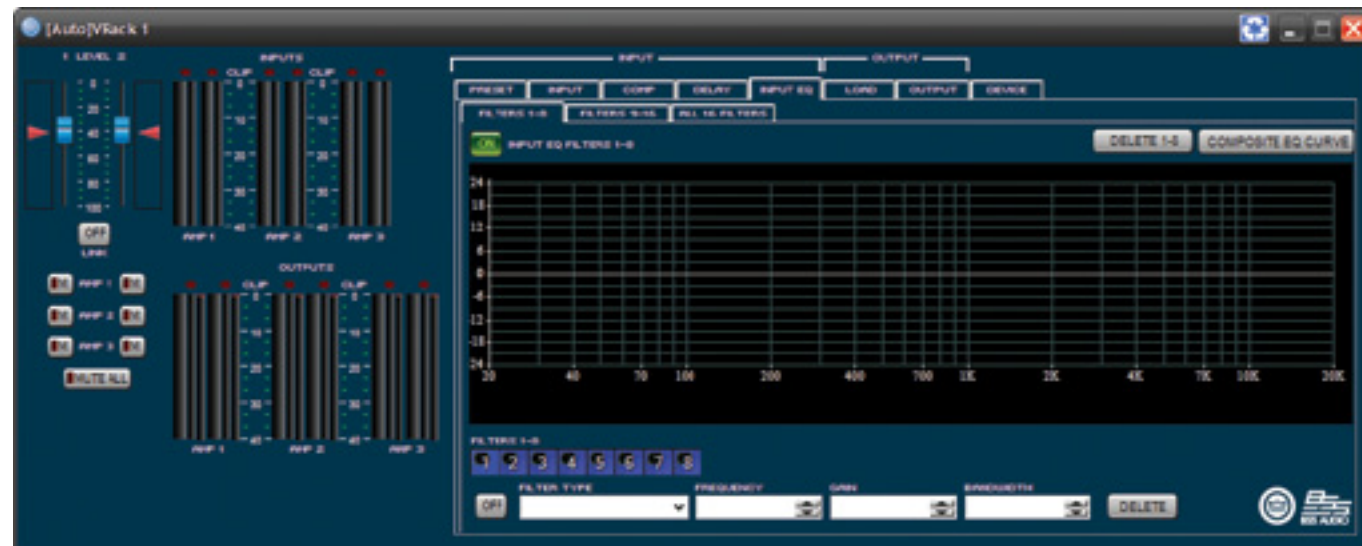

# HiQnet™ Software

## Load Output Tab

Channel 1 Load Monitoring  
Enable / Disable

Channel 2 Load Monitoring  
Enable / Disable



## Device Tab

Single click on the device to select amplifier-specific settings not included in the VRack device panel. By selecting one of the amplifiers, the standard I-Tech HD device panel will appear.

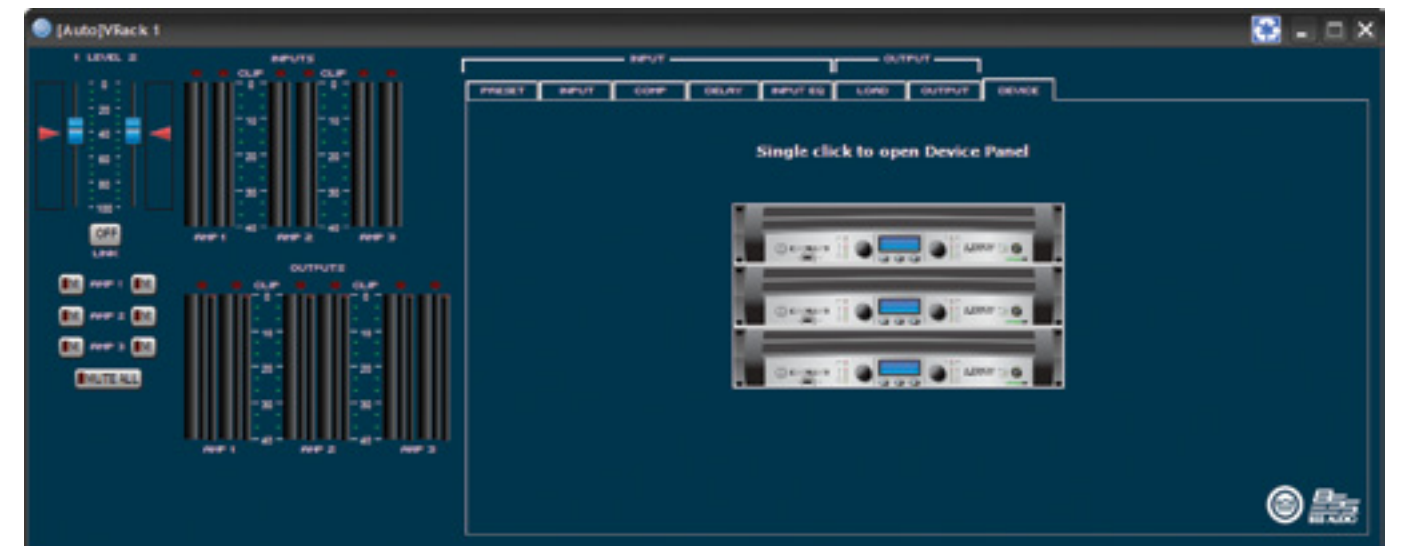

# HiQnet™ Software

## Designing and Recalling Presets

The VRack Preset Tab recalls the same preset numbers on all amplifiers; therefore, it is recommended you save system-specific presets by preset numbers.

Below is an example of how to set up a 3-Way + Sub VerTec 4889/4880 preset.

Step 1: Select output mode for the application. This example is 3-way+Sub, done using OEM JBL Pro factory presets. (Available in c:\...My Documents\HPro... or online at www.jblpro.com)

Step 2: Open the device panel for the amplifier and load bandpass presets based on above Output Operation Mode.

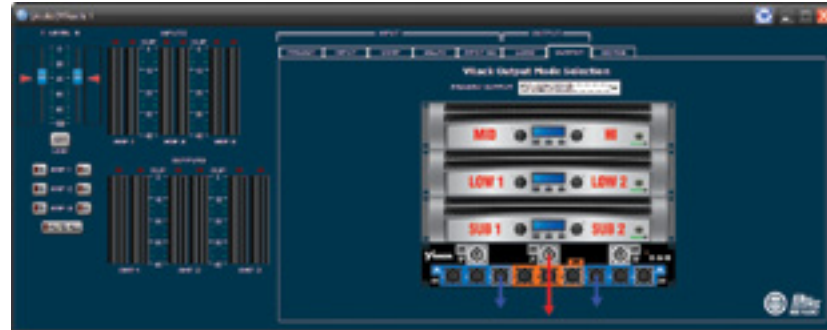

Step 3: Open the device panel for the amplifier and load bandpass presets based on above output operation mode.

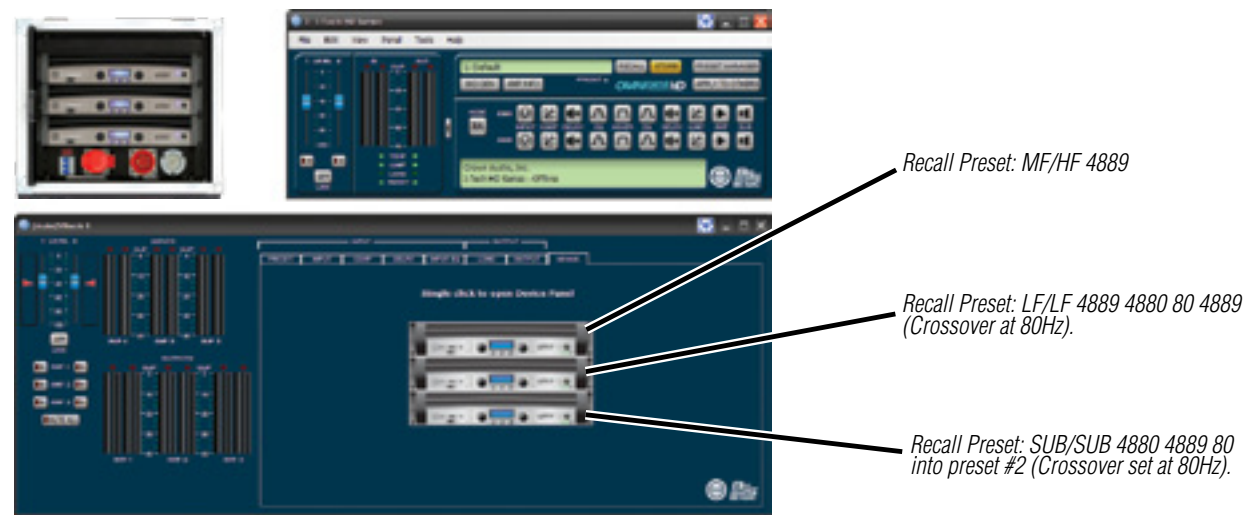

Step 4: Store presets as 4889/4980 80 VRACK, in an empty memory location in all 3 amplifiers.



Step 5: Repeat as needed for 60 and X crossovers.

Step 6: Recalling preset will reconfigure VRack amplifiers for desired operation.

# System Diagrams

3 Way + 3 Way  
4 x XVT4889

## On Each V-Rack

No.	Section	Load
2	HF	8 ohm
2	MF	4 ohm
4	LF	2 ohm

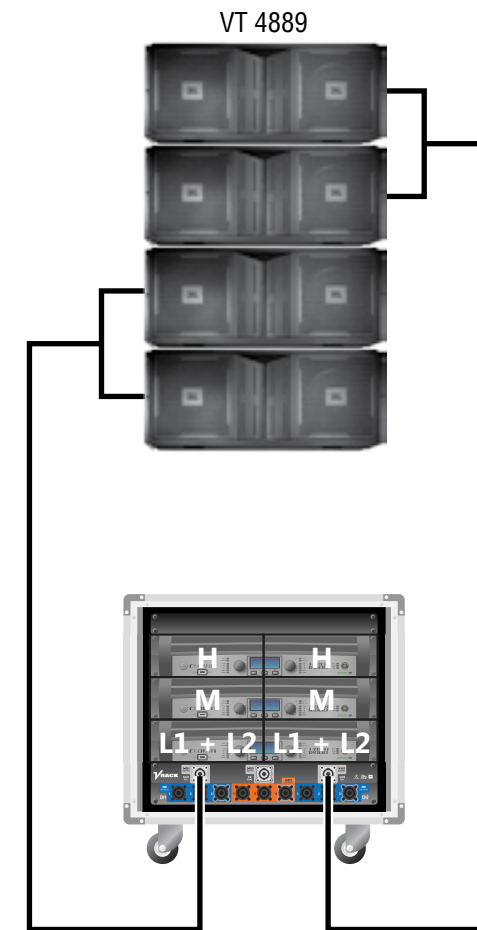



# System Diagrams

3 Way + Sub  
6 x VT4889 + 4 x VT4880A

On Each V-Rack

No.	Section	Load	CH. 1	CH. 2	
3	MF	2.7 ohm	CH. 1	CH. 2	Top Amp.
3	HF	5.3 ohm	CH. 1	CH. 2	
3	LF	2.7 ohm	CH. 1	CH. 2	Ctr. Amp.
3	LF	2.7 ohm	CH. 1	CH. 2	
1	SUB	4 ohm	CH. 1	CH. 2	Btm. Amp.
1	SUB	4 ohm	CH. 1	CH. 2	

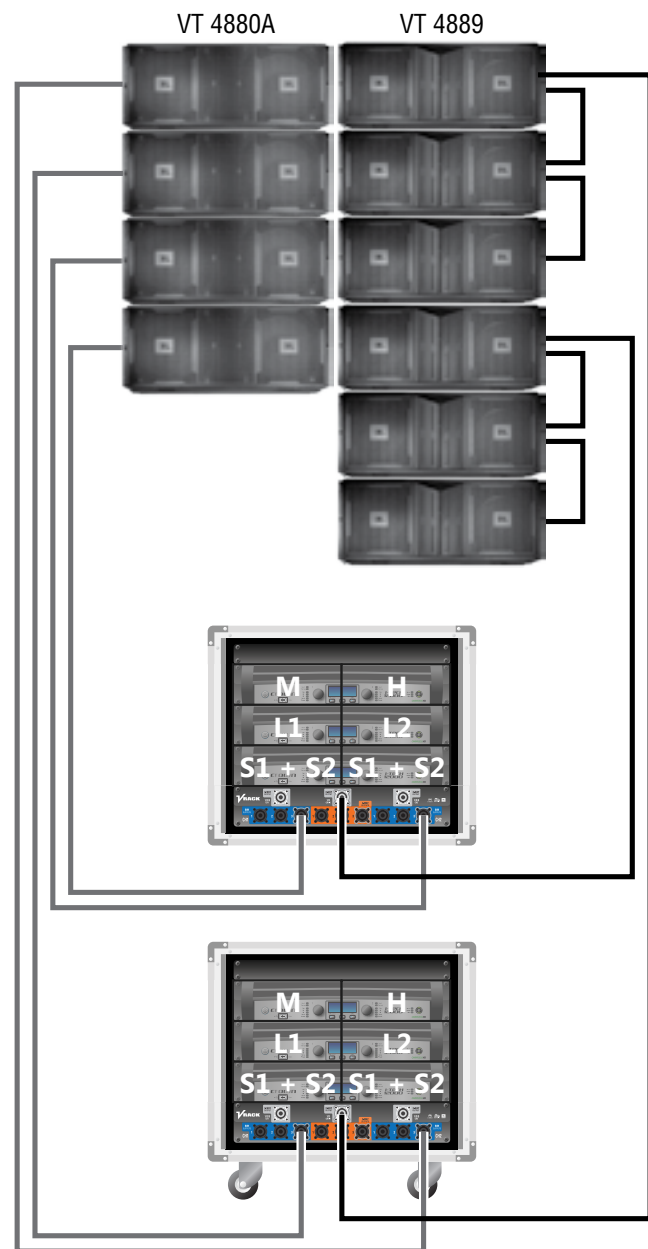

# System Diagrams

2 Way + Sub  
3 x VT4887A + 1 x VT4881A

V-Rack Option 1

No.	Section	Load	CH. 1	CH. 2	
3	MF/HF	2.7 ohm	CH. 1	CH. 2	Top Amp.
3	MF/HF	2.7 ohm	CH. 1	CH. 2	
3	LF	2.7 ohm	CH. 1	CH. 2	Ctr. Amp.
3	LF	2.7 ohm	CH. 1	CH. 2	
1	SUB	8 ohm	CH. 1	CH. 2	Btm. Amp.
1	SUB	8 ohm	CH. 1	CH. 2	

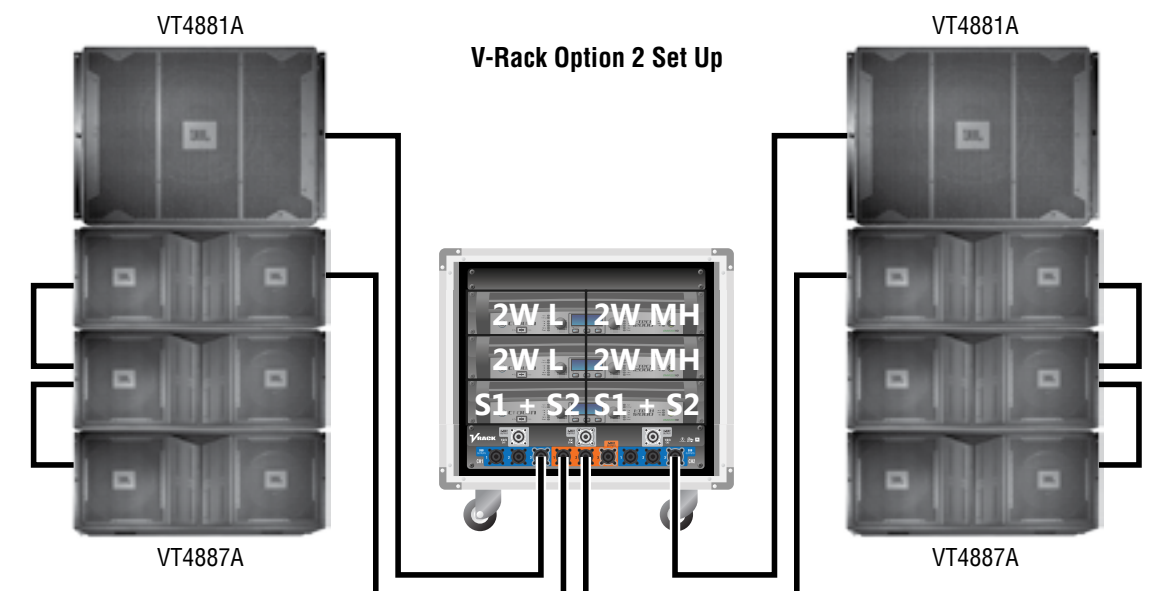
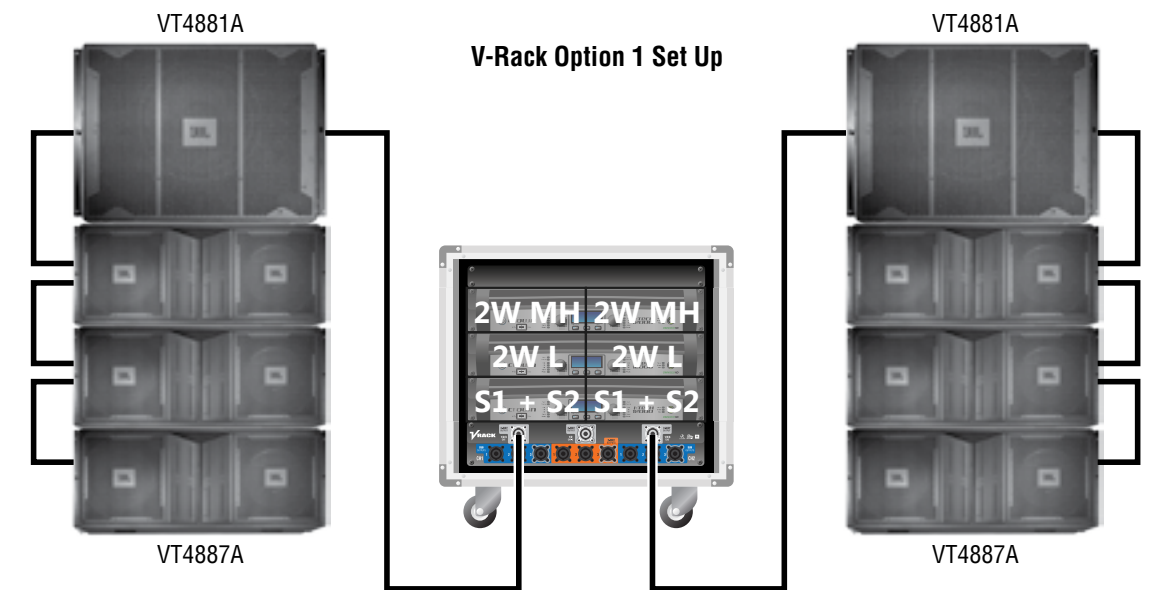

# System Diagrams

Passive + Sub  
6 x VT4886 + 2 x VT4883

On Each V-Rack

No.	Section	Load	CH. 1	CH. 2	
3	LMH	4 ohm	CH. 1	CH. 2	Top Amp.
3	LMH	4 ohm	CH. 1	CH. 2	
3	LMH	4 ohm	CH. 1	CH. 2	Ctr. Amp.
3	LMH	4 ohm	CH. 1	CH. 2	
2	SUB	2 ohm	CH. 1	CH. 2	Btm. Amp.
2	SUB	2 ohm	CH. 1	CH. 2	

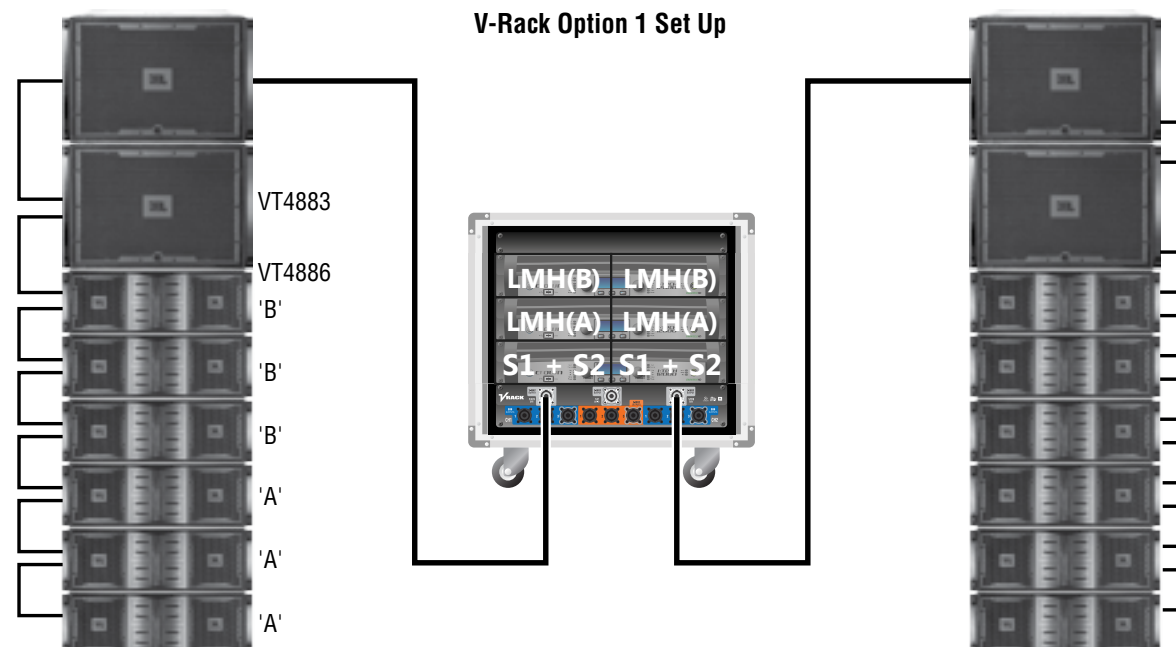

Passive + Sub  
8 x VT4886 + 3 x VT4883 + 2 x VT4880A

On Each V-Rack

No.	Section	Load	CH. 1	CH. 2	
4	LMH	3 ohm	CH. 1	CH. 2	Top Amp.
4	LMH	3 ohm	CH. 1	CH. 2	
3	SUB (1+/-)	2.7 ohm	CH. 1	CH. 2	Ctr. Amp.
3	SUB (2+/-)	2.7 ohm	CH. 1	CH. 2	
1	SUB	4 ohm	CH. 1	CH. 2	Btm. Amp.
1	SUB	4 ohm	CH. 1	CH. 2	

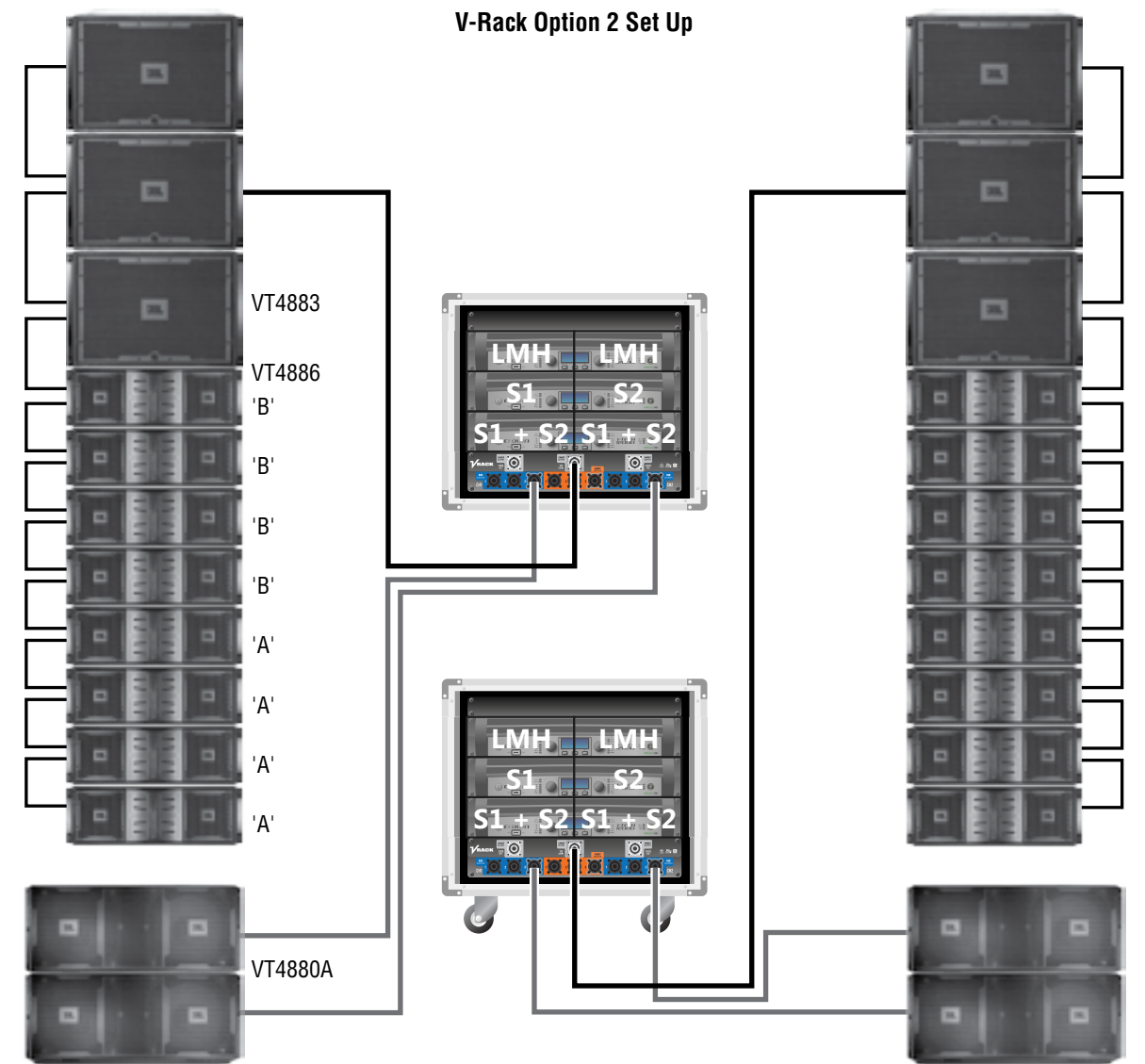



## PRODUCT REGISTRATION

Crown Audio, Inc.  
1718 W. Mishawaka Rd.  
Elkhart, IN 46517-9439  
Phone: 574-294-8000  
Fax: 574-294-8329  
www.crownaudio.com

Online registration is also available at <http://crownweb.crownintl.com/webregistration>.

*\*Warranty is only valid within the United States of America. For information on Warranty outside of the U.S.A, please contact your local distributor.*

When this form is used to register your product, it may be mailed or faxed.

Crown Audio, Inc. Fax: 574-294-8329  
1718 W. Mishawaka Rd.  
Elkhart, IN 46517-9439

Please note that some information is required. Incomplete registrations will not be processed. \* Indicates required information.

### OWNER'S INFORMATION – PLEASE PRINT

\* First name: \_\_\_\_\_ Middle initial: \_\_\_\_\_ \* Last name: \_\_\_\_\_  
Company: \_\_\_\_\_  
\* Mailing address: \_\_\_\_\_  
\* City: \_\_\_\_\_ \* State: \_\_\_\_\_ \* ZIP code: \_\_\_\_\_  
\* Country: \_\_\_\_\_ E-mail address: \_\_\_\_\_  
\* Phone # (include area code): \_\_\_\_\_ Fax #: \_\_\_\_\_

### PRODUCT INFORMATION

* MODEL e.g., IT8000, CDi1000, PCC16	* SERIAL # e.g., 800000000	* PURCHASE DATE mo/day/yr
_____	_____	___/___/___
_____	_____	___/___/___
_____	_____	___/___/___
_____	_____	___/___/___

Product purchased from:\*(Business/Individual) \_\_\_\_\_ Country: \_\_\_\_\_

Comments: \_\_\_\_\_  
\_\_\_\_\_  
\_\_\_\_\_

THIS PAGE INTENTIONALLY LEFT BLANK

CUT ON THIS LINE

## Crown Audio Factory Service Information

Shipping Address: Crown Audio Factory Service, 1718 W. Mishawaka Rd., Elkhart, IN 46517-9439

### PLEASE PRINT CLEARLY

SRA #: \_\_\_\_\_ (if sending product to Crown factory service)

Model: \_\_\_\_\_ Serial number: \_\_\_\_\_ Purchase date: \_\_\_\_\_

### PRODUCT RETURN INFORMATION

Individual or business name: \_\_\_\_\_

Phone #: \_\_\_\_\_ Fax #: \_\_\_\_\_ E-mail: \_\_\_\_\_

Street address (please, no P.O. Boxes): \_\_\_\_\_

City: \_\_\_\_\_ State/Prov: \_\_\_\_\_ Postal code: \_\_\_\_\_ Country: \_\_\_\_\_

Nature of problem: \_\_\_\_\_

\_\_\_\_\_

\_\_\_\_\_

\_\_\_\_\_

Other equipment in your system: \_\_\_\_\_

If warranty is expired, please provide method of payment. Proof of purchase may be required to validate warranty.

### PAYMENT OPTIONS

I have open account payment terms. Purchase order required. PO#: \_\_\_\_\_  COD

Credit Card (Information below is required; however, if you do not want to provide this information at this time, we will contact you when your unit is repaired for the information.)

Credit card information:

Type of credit card:  MasterCard  Visa  American Express  Discover

Type of credit card account:  Personal/Consumer  Business/Corporate

Card # \_\_\_\_\_ Exp. date: \_\_\_\_\_ \*Card ID #: \_\_\_\_\_

\*Card ID # is located on the back of the card following the credit card #, in the signature area. On American Express, it may be located on the front of the card. This number is required to process the charge to your account. If you do not want to provide it at this time, we will call you to obtain this number when the repair of your unit is complete.

Name on credit card: \_\_\_\_\_

Billing address of credit card: \_\_\_\_\_

\_\_\_\_\_

\_\_\_\_\_

THIS PAGE INTENTIONALLY LEFT BLANK



***CROWN***<sup>®</sup>  
by **HARMAN**