



## Studer Vista FX

*Option to Vista Digital Mixing Systems  
(from SW Version 4.9 or higher)*

## **Disclaimer**

---

The information in this document has been carefully checked and is believed to be accurate at the time of publication. However, no responsibility is taken by us for inaccuracies, errors, or omissions, nor is any liability assumed for any loss or damage resulting either directly or indirectly from use of the information contained within it.

Prepared and edited by  
Studer Professional Audio GmbH  
Technical Documentation  
Riedthofstrasse 214  
CH-8105 Regensdorf - Switzerland  
<http://www.studer.ch>

Copyright by Studer Professional Audio GmbH

Order no. 5012362 (0814)

Subject to change

## For Your Own Safety and to Avoid Invalidation of the Warranty Please Read This Section Carefully

---

- Read these instructions.
- Keep these instructions.
- Heed all warnings.
- Follow all instructions.
- Do not use this apparatus near water.
- Clean only with a dry cloth.
- Do not block any ventilation openings. Install in accordance with the manufacturer's instructions.
- Do not install near any heat sources such as radiators, heat registers, stoves, or other apparatus (including amplifiers) that produce heat.
- Do not defeat the safety purpose of a polarised or grounding type plug. A polarised plug has two blades with one wider than the other. A grounding type plug has two blades and a third grounding prong. The wide blade or the third prong are provided for your safety. If the provided plug does not fit into your outlet, consult an electrician for replacement of the obsolete outlet
- Protect the power cord from being walked on or pinched particularly at plugs, convenience receptacles and the point where they exit from the apparatus.
- Only use attachments/accessories specified by the manufacturer.
- Use only with the cart, stand, tripod, bracket or table specified by the manufacturer, or sold with the apparatus. When a cart is used, use caution when moving the cart/apparatus combination to avoid injury from tip-over.
- Refer all servicing to qualified service personnel. Servicing is required when the apparatus has been damaged in any way, such as the power supply cord or plug is damaged, liquid has been spilled or objects fallen into the apparatus, the apparatus has been exposed to rain or moisture, does not operate normally, or has been dropped.

**Note:** It is recommended that all maintenance and service on the product should be carried out by Studer or its authorised agents. Studer cannot accept any liability whatsoever for any loss or damage caused by service, maintenance or repair by unauthorised personnel.

**WARNING:** To reduce the risk of fire or electric shock, do not expose this apparatus to rain or moisture. Do not expose the apparatus to dripping or splashing and do not place objects filled with liquids, such as vases, on the apparatus.

- No naked flame sources, such as lighted candles, should be placed on the apparatus.
- Ventilation should not be impeded by covering the ventilation openings with items such as newspapers, table cloths, curtains etc.

**WARNING:** Do not use this apparatus in very dusty atmospheres, or in atmospheres containing flammable gases or chemicals.

- **THIS APPARATUS MUST BE EARTHED.** Under no circumstances should the safety earth be disconnected from the mains lead.
- The mains supply disconnect device is the mains plug. It must remain accessible so as to be readily operable when the apparatus is in use.
- If any part of the mains cord set is damaged, the complete cord set should be replaced. The following information is for reference only. The wires in the mains lead are coloured in accordance with the following code:

- **Protective Earth (Ground): Green/Yellow (US: Green or Green/Yellow)**
- **Neutral: Blue (US: White)**
- **Live (Hot): Brown (US: Black)**

As the colours of the wires in the mains lead may not correspond with the coloured markings identifying the terminals in your plug, proceed as follows:

- **The wire which is coloured Green and Yellow must be connected to the terminal in the plug which is marked with the letter E or by the earth symbol.**
- **The wire which is coloured Blue must be connected to the terminal in the plug which is marked with the letter N.**
- **The wire which is coloured Brown must be connected to the terminal in the plug which is marked with the letter L.**

Ensure that these colour codes are followed carefully in the event of the plug being changed

- **This unit is capable of operating over a range of mains voltages, as marked on the rear panel.**

**Lithium Battery**



Installed lithium batteries must be replaced by the same or an equivalent type. Danger of explosion if batteries are incorrectly replaced or when terminals are shorted.

Installed lithium batteries must not be exposed to excessive heat such as direct sunshine, fire or the like.

**Note:**

This equipment has been tested and found to comply with the limits for a Class A digital device, pursuant to Part 15 of the FCC Rules. These limits are designed to provide reasonable protection against harmful interference when the equipment is operated in a commercial environment. This equipment generates, uses and can radiate radio frequency energy and, if not installed and used in accordance with the instruction manual, may cause harmful interference to radio communications. Operation of this equipment in a residential area is likely to cause harmful interference in which case the user will be required to correct the interference at his own expense.

This Class A digital apparatus meets the requirements of the Canadian Interference-Causing Equipment Regulations.

Cet appareil numérique de la Classe A respecte toutes les exigences du Règlement sur le matériel brouilleur du Canada.

**Working Safely With Sound**

Although your new console will not make any noise until you feed it signals, it has the capability to produce sounds that, when monitored through a monitor system or headphones, can damage hearing over time. The table below is taken from the Occupational Safety & Health Administration directive on occupational noise exposure (1926.52):

**Permissible Noise Exposure:**



Duration per day [h]	Sound level [dBA, slow response]
8	90
6	92
4	95
3	97
2	100
1.5	102
1	105
0.5	110
<0.25	115

Conforming to this directive will minimise the risk of hearing damage caused by long listening periods. A simple rule to follow is: The longer you listen, the lower the average volume should be. Please take care when working with your audio system – if you are manipulating controls which you don't understand (which we all do when we are learning), make sure your monitoring level is turned down. *Remember that your ears are the most important tool of your trade. Look after them, and they will look after you. Most importantly: Don't be afraid to experiment to find out how each parameter affects the sound; this will extend your creativity and help you to get the best results.*

**A1 Safety Symbol Guide**

For your own safety and to avoid invalidation of the warranty, all text marked with these symbols should be read carefully.



To reduce the risk of electric shock, do not remove covers. No user-serviceable parts inside. Refer servicing to qualified service personnel (i.e., persons having appropriate technical training and experience necessary to be aware of hazards to which they are exposed in performing a repair action, and of measures to minimize the danger of themselves).



The lightning flash with arrowhead symbol is intended to alert the user to the presence of un-insulated “dangerous voltage” within the product’s enclosure that may be of sufficient magnitude to constitute a risk of electric shock to persons.



The exclamation point within an equilateral triangle is intended to alert the user to the presence of important operating and maintenance (servicing) instructions in the literature accompanying the appliance.



Headphones safety warnings contain important information and useful tips on headphone outputs and monitoring levels.



Assemblies or sub-assemblies of this product can contain opto-electronic devices. As long as these devices comply with Class I of laser or LED products according to EN 60825-1:1994, they will not be expressly marked on the product. If a special design should be covered by a higher class of this standard, the device concerned will be marked directly on the assembly or sub-assembly in accordance with the above standard.



**A2 First Aid**

**In Case of Electric Shock:**

Separate the person as quickly as possible from the electric power source:

- By switching the equipment off,
- By unplugging or disconnecting the mains cable, or
- By pushing the person away from the power source, using dry insulating material (such as wood or plastic).
- After having suffered an electric shock, always consult a doctor.

**Warning!**



***Do not touch the person or his clothing before the power is turned off, otherwise you stand the risk of suffering an electric shock as well!***

**If the Person is Unconscious:**

- Lay the person down
- Turn him to one side
- Check the pulse
- Reanimate the person if respiration is poor
- Call for a doctor immediately.

## **B General Installation Instructions**

---

Please consider besides these general instructions also any product-specific instructions in the “Installation” chapter of this manual.

### **B1 Unpacking**

---

Check the equipment for any transport damage. If the unit is mechanically damaged, if liquids have been spilled or if objects have fallen into the unit, it must not be connected to the AC power outlet, or it must be immediately disconnected by unplugging the power cable. Repair must only be performed by trained personnel in accordance with the applicable regulations.

### **B2 Installation Site**

---

Install the unit in a place where the following conditions are met:

- The temperature and the relative humidity of the environment must be within the specified limits during operation of the unit. Relevant values are the ones at the air inlets of the unit (refer to Appendix 1).
- Condensation must be avoided. If the unit is installed in a location with large variation of ambient temperature (e.g. in an OB-van), appropriate precautions must be taken before and after operation (refer to Appendix 1).
- Unobstructed air flow is essential for proper operation. Air vents of the unit are a functional part of the design and must not be blocked in any way during operation (e.g. by objects placed upon them, placement of the unit on a soft surface, or installation of the unit within a rack or piece of furniture).
- The unit must not be heated up by external sources of heat radiation (sunlight, spotlights).

### **B3 Earthing and Power Supply**

---

Earthing of units with mains supply (class I equipment) is performed via the protective earth (PE) conductor integrated in the mains cable. Units with battery operation (< 60 V, class III equipment) must be earthed separately. Earthing the unit is one of the measures for protection against electrical shock hazard (dangerous body currents). Hazardous voltage may not only be caused by a defective power supply insulation, but may also be introduced by the connected audio or control cables.

If the unit is installed with one or several external connections, its earthing must be provided during operation as well as while the unit is not operated. If the earthing connection can be interrupted, for example, by unplugging the mains plug of an external power supply unit, an additional, permanent earthing connection must be installed using the provided earth terminal.

Avoid ground loops (hum loops) by keeping the loop surface as small as possible (by consequently guiding the earth conductors in a narrow, parallel way), and reduce the noise current flowing through the loop by inserting an additional impedance (common-mode choke).

**Class I Equipment (Mains Operation)**

Should the equipment be delivered without a matching mains cable, the latter has to be prepared by a trained person using the attached female plug (IEC 320 / C13 or IEC 320 / C19) with respect to the applicable regulations in your country.

Before connecting the equipment to the AC power outlet, check that the local line voltage matches the equipment rating (voltage, frequency) within the admissible tolerance. The equipment fuses must be rated in accordance with the specifications on the equipment.

Equipment supplied with a 3-pole appliance inlet (protection conforming to class I equipment) must be connected to a 3-pole AC power outlet in such a way that the equipment cabinet is connected to the protective earth.

For information on mains cable strain relief, please refer to Appendix 2.

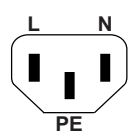
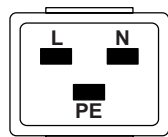
Female Plugs (IEC320), Front-Side View:		
 		
	IEC 320 / C13	IEC 320 / C19
European Standard (CENELEC)		North American Standard (NAS)
Brown	L (Live)	Black
Blue	N (Neutral)	White
Green/Yellow	PE (Protective Earth)	Green (or Green/Yellow)

**Class III Equipment (Battery Operation up to 60 VDC)**

Equipment of this protection class must be earthed using the provided earth terminal if one or more external signals are connected to the unit (see explanation at the beginning of this paragraph).

**B4 Electromagnetic Compatibility (EMC)**

The unit conforms to the protection requirements relevant to electromagnetic phenomena that are listed in guidelines 89/336/EC and FCC, part 15.

- The electromagnetic interference generated by the unit is limited in such a way that other equipment and systems can be operated normally.
- The unit is adequately protected against electromagnetic interference so that it can operate properly.

The unit has been tested and conforms to the EMC standards of the specified electromagnetic environment, as listed in the following declaration. The limits of these standards ensure protection of the environment and corresponding noise immunity of the equipment with appropriate probability. However, a professional installation and integration within the system are imperative prerequisites for operation without EMC problems.

For this purpose, the following measures must be followed:

- Install the equipment in accordance with the operating instructions. Use the supplied accessories.
- In the system and in the vicinity where the equipment is installed, use only components (systems, equipment) that also fulfill the EMC standards for the given environment.

- Use a system grounding concept that satisfies the safety requirements (class I equipment must be connected with a protective ground conductor) and that also takes into consideration the EMC requirements. When deciding between radial, surface, or combined grounding, the advantages and disadvantages should be carefully evaluated in each case.
- Use shielded cables where shielding is specified. The connection of the shield to the corresponding connector terminal or housing should have a large surface and be corrosion-proof. Please note that a cable shield connected only single-ended can act as a transmitting or receiving antenna within the corresponding frequency range.
- Avoid ground loops or reduce their adverse effects by keeping the loop surface as small as possible, and reduce the noise current flowing through the loop by inserting an additional impedance (e.g. common-mode choke).
- Reduce electrostatic discharge (ESD) of persons by installing an appropriate floor covering (e.g. a carpet with permanent electrostatic filaments) and by keeping the relative humidity above 30%. Further measures (e.g. conducting floor) are usually unnecessary and only effective if used together with corresponding personal equipment.
- When using equipment with touch-sensitive operator controls, please take care that the surrounding building structure allows for sufficient capacitive coupling of the operator. This coupling can be improved by an additional, conducting surface in the operator's area, connected to the equipment housing (e.g. metal foil underneath the floor covering, carpet with conductive backing).

## C Maintenance

All air vents and openings for operating elements (faders, rotary knobs) must be checked on a regular basis, and cleaned in case of dust accumulation. For cleaning, a soft paint-brush or a vacuum cleaner is recommended. Cleaning the surfaces of the unit is performed with a soft, dry cloth or a soft brush.

Persistent contamination can be treated with a cloth that is slightly humidified with a mild cleaning solution, such as dishwashing detergent.

For cleaning display windows, commercially available computer/TV screen cleaners are suited. Use only a slightly damp (never wet) cloth.

Never use any solvents for cleaning the exterior of the unit! Liquids must never be sprayed or poured on directly!

For equipment-specific maintenance information please refer to the corresponding chapter in the operating and service manuals.

## D Electrostatic Discharge during Maintenance and Repair

Caution:



**Observe the precautions for handling devices sensitive to electrostatic discharge!**

Many semiconductor components are sensitive to electrostatic discharge (ESD). The lifespan of assemblies containing such components can be drastically reduced by improper handling during maintenance and repair. Please observe the following rules when handling ESD sensitive components:

- ESD sensitive components should only be stored and transported in the packing material specifically provided for this purpose.



- When performing a repair by replacing complete assemblies, the removed assembly must be sent back to the supplier in the same packing material in which the replacement assembly was shipped. If this should not be the case, any claim for a possible refund will be null and void.
- Unpacked ESD sensitive components should only be handled in ESD protected areas (EPA, e.g. area for field service, repair or service bench) and only be touched by persons wearing a wristlet connected to the ground potential of the repair or service bench by a series resistor. The equipment to be repaired or serviced as well as all tools and electrically semi-conducting work, storage, and floor mats should also be connected to this ground potential.
- The terminals of ESD sensitive components must not come in uncontrolled contact with electrostatically chargeable or metallic surfaces (voltage puncture, discharge shock hazard).
- To prevent the components from undefined transient stress and possible damage due to inadmissible voltages or compensation currents, electrical connections should only be established or separated when the equipment is switched off and after any capacitor charges have decayed.

## **E Repair**

---

By removing housing parts or shields, energized parts may be exposed. For this reason the following precautions must be observed:

- Maintenance may only be performed by trained personnel in accordance with the applicable regulations.
- The equipment must be switched off and disconnected from the AC power outlet before any housing parts are removed.
- Even if the equipment is disconnected from the power outlet, parts with hazardous charges (e.g. capacitors, picture tubes) must not be touched until they have been properly discharged. Do not touch hot components (power semiconductors, heat sinks, etc.) before they have cooled off.
- If maintenance is performed on a unit that is opened while being switched on, no un-insulated circuit components and metallic semiconductor housings must be touched, neither with bare hands nor with un-insulated tools.

Certain components pose additional hazards:

- Explosion hazard from lithium batteries, electrolytic capacitors and power semiconductors (Observe the component's polarity. Do not short battery terminals. Replace batteries only by the same type).
- Implosion hazard from evacuated display units.
- Radiation hazard from laser units (non-ionizing), picture tubes (ionizing).
- Caustic effect of display units (LCD) and components containing liquid electrolyte.

Such components should only be handled by trained personnel who are properly protected (e.g. protection glasses, gloves).

**E1 SMD Components**

Studer has no commercially available SMD components in stock for service purposes. For repair, the corresponding devices have to be purchased locally. The specifications of special components can be found in the service manual. SMD components should only be replaced by skilled specialists using appropriate tools. No warranty claims will be accepted for circuit boards that have been damaged. Proper and improper SMD soldering joints are illustrated below.

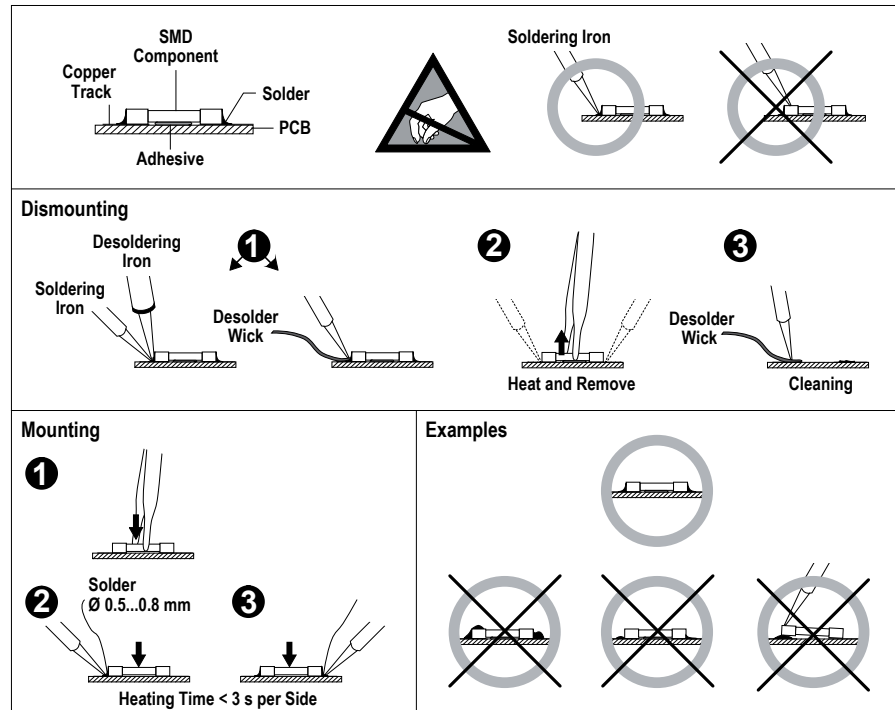

**F Disposal**

**Packing Materials**

The packing materials have been selected with environmental and disposal issues in mind. All packing material can be recycled. Recycling packing saves raw materials and reduces the volume of waste. If you need to dispose of the transport packing materials, please try to use recyclable means.

**Used Equipment**

Used equipment contains valuable raw materials as well as materials that must be disposed of professionally. Please return your used equipment via an authorized specialist dealer or via the public waste disposal system, ensuring any material that can be recycled is. Please take care that your used equipment cannot be abused. To avoid abuse, delete sensitive data from any data storage media. After having disconnected your used equipment from the mains supply, make sure that the mains connector and the mains cable are made useless.

## G Declarations of Conformity

### G1 Class A Equipment - FCC Notice

This equipment has been tested and found to comply with the limits for a Class A digital device, pursuant to Part 15 of the FCC Rules. These limits are designed to provide a reasonable protection against harmful interference when the equipment is operated in a commercial environment. This equipment generates, uses, and can radiate radio frequency energy and, if not installed and used in accordance with the instruction manual, may cause harmful interference to radio communications. Operation of this equipment in a residential area is likely to cause harmful interference, in which case the user will be required to correct the interference at his own expense.

This Class A digital apparatus meets the requirements of the Canadian Interference-Causing Equipment Regulations.

Cet appareil numérique de la Classe A respecte toutes les exigences du Règlement sur le matériel brouilleur du Canada.

*Caution: Any changes or modifications not expressly approved by the manufacturer could void the user's authority to operate the equipment. Also refer to relevant information in this manual.*

### G2 CE Declaration of Conformity

We,  
**Studer Professional Audio GmbH,**  
**CH-8105 Regensdorf,**  
 declare under our sole responsibility that the product  
**Studer Vista FX, Digital Effects Processor**  
**(starting with serial no. 1001),**  
 to which this declaration relates, according to following regulations of EU directives and amendments

- Low Voltage (LVD):  
73/23/EEC + 93/68/EEC
- Electromagnetic Compatibility (EMC):  
89/336/EEC + 92/31/EEC + 93/68/EEC

is in conformity with the following standards or normative documents:

- Safety:  
EN 60065:2002 (Class I equipment)
- Safety of laser products:  
EN 60825-1:1994 + A11 + A2, EN 60825-2:2000
- EMC:  
EN 55103-1/-2:2009, electromagnetic environment E2.

Regensdorf, April 15, 2013



B. Hochstrasser, General Manager



M. Lienert, Manager R&D

## Appendix 1: Air Temperature and Humidity

### General

Normal operation of the unit or system is warranted under the ambient conditions defined by *EN 60721-3-3, set IE32, value 3K3*.

This standard consists of an extensive catalogue of parameters, the most important of which are: ambient temperature +5...+40 °C, relative humidity 5...85% (i.e., no formation of condensation or ice); absolute humidity 1...25 g/m<sup>3</sup>; rate of temperature change < 0.5 °C/min. These parameters are dealt with in the following paragraphs.

Under these conditions the unit or system starts and works without any problem. Beyond these specifications, possible problems are described below.

### Ambient Temperature

Units and systems by Studer are generally designed for an ambient temperature range (i.e. temperature of the incoming air) of +5 °C to +40 °C. When rack mounting the units, the intended air flow and herewith adequate cooling must be provided. The following facts must be considered:

- The admissible ambient temperature range for operation of the semiconductor components is 0 °C to +70 °C (commercial temperature range for operation).
- The air flow through the installation must provide that the outgoing air is always cooler than 70 °C.
- Average heat increase of the cooling air shall be about 20 K, allowing for an additional maximum 10 K increase at the hot components.
- In order to dissipate 1 kW with this admissible average heat increase, an air flow of 2.65 m<sup>3</sup>/min is required.

**Example:** A rack dissipating  $P = 800 \text{ W}$  requires an air flow of  $0.8 * 2.65 \text{ m}^3/\text{min}$  which corresponds to  $2.12 \text{ m}^3/\text{min}$ .

- If the cooling function of the installation must be monitored (e.g. for fan failure or illumination with spot lamps), the outgoing air temperature must be measured directly above the modules at several places within the rack. The trigger temperature of the sensors should be 65 °C to 70 °C.

### Frost and Dew

The unsealed system parts (connector areas and semiconductor pins) allow for a minute formation of ice or frost. However, formation of dew visible to the naked eye will already lead to malfunctions. In practice, reliable operation can be expected in a temperature range above -15 °C, if the following general rule is considered for putting the cold system into operation:

If the air within the system is cooled down, the relative humidity rises. If it reaches 100%, condensation will arise, usually in the boundary layer between the air and a cooler surface, together with formation of ice or dew at sensitive areas of the system (contacts, IC pins, etc.). Once internal condensation occurs, trouble-free operation cannot be guaranteed, independent of temperature.

Before putting into operation, the system must be checked for internal formation of condensation or ice. Only with a minute formation of ice, direct

evaporation (sublimation) may be expected; otherwise the system must be heated and dried while switched off.

A system without visible internal formation of ice or condensation should be heated up with its own heat dissipation, as homogeneously (and subsequently as slow) as possible; the ambient temperature should then always be lower than the one of the outgoing air.

If it is absolutely necessary to operate the cold system immediately within warm ambient air, this air must be dehydrated. In such a case, the absolute humidity must be so low that the relative humidity, related to the coldest system surface, always remains below 100%.

Ensure that the enclosed air is as dry as possible when powering off (i.e. before switching off in winter, aerate the room with cold, dry air, and remove humid objects such as clothes from the room).

These relationships are visible from the following climatogram. For a controlled procedure, thermometer and hygrometer as well as a thermometer within the system will be required.

**Example 1:** An OB-van having an internal temperature of +20 °C and a relative humidity of 40% is switched off in the evening. If the temperature falls below +5 °C, the relative humidity will rise to 100% (7 g/m<sup>3</sup>); dew or ice will be forming.

**Example 2:** An OB-van is heated up in the morning with air of +20 °C and a relative humidity of 40%. On all parts being cooler than +5 °C, dew or ice will be forming.

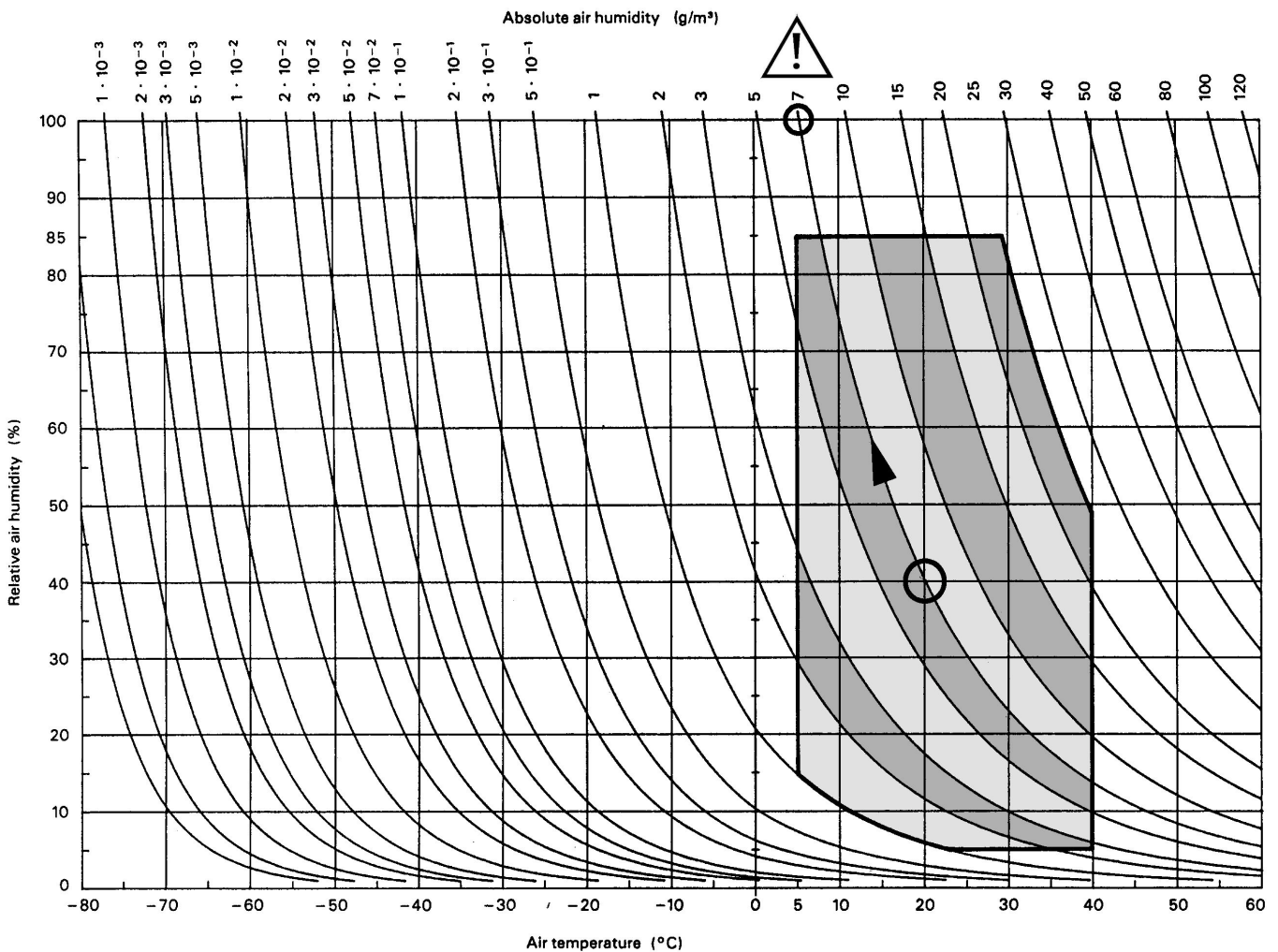

## Appendix 2: Mains Connector Strain Relief

For anchoring connectors without a mechanical lock (e.g. IEC mains connectors), we recommend the following arrangement:

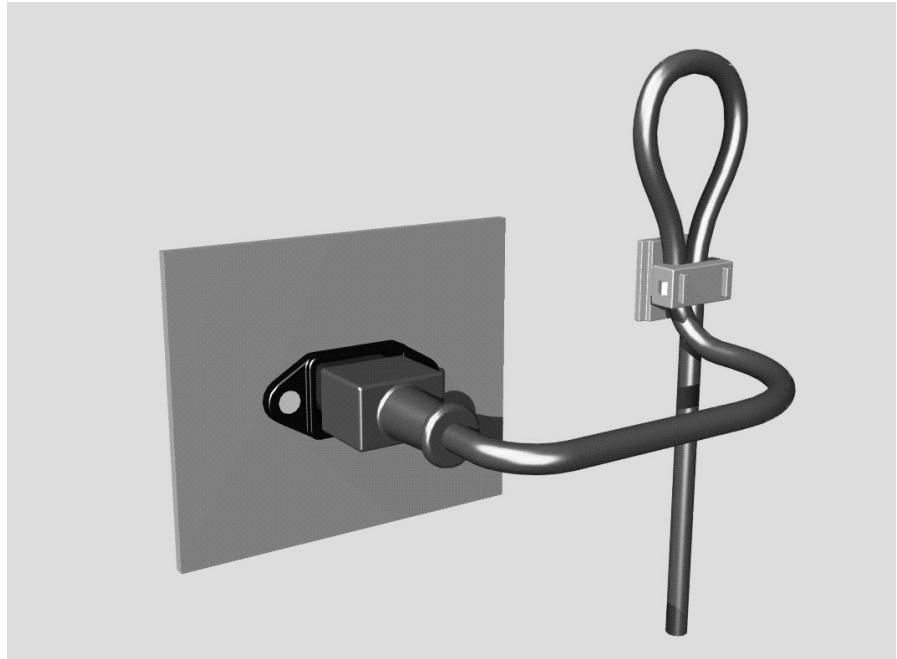

- Procedure:** The cable clamp shipped with your unit is auto-adhesive. For mounting please follow the rules below:
- The surface to be adhered to must be clean, dry, and free from grease, oil, or other contaminants. Recommended application temperature range is +20 °C to +40 °C.
  - Remove the plastic protective backing from the rear side of the clamp and apply it firmly to the surface at the desired position. Allow as much time as possible for curing. The bond continues to develop for as long as 24 hours.
  - For improved stability, the clamp should be fixed with a screw. For this purpose, a self-tapping screw and an M4 bolt and nut are included.
  - Place the cable into the clamp as shown in the illustration above and firmly press down the internal top cover until the cable is fixed.

## Appendix 3: Software License

---

*Use of the software is subject to the Studer Professional Audio Software License Agreement set forth below. Using the software indicates your acceptance of this license agreement. If you do not accept these license terms, you are not authorized to use this software.*

Under the condition and within the scope of the following Terms and Conditions, Studer Professional Audio GmbH (hereinafter ‘Studer’) grants the right to use programs developed by Studer as well as those of third parties which have been installed by Studer on or within its products. References to the license programs shall be references to the newest release of a license program installed at the Customer’s site.

### Programs Covered by the Agreement

---

**License Programs of Studer** The following Terms and Conditions grant the right to use all programs of Studer that are part of the System and/or its options at the time of its delivery to the Customer, as well as the installation software on the original data disk and the accompanying documentation (‘License Material’). In this Agreement the word ‘Programs’ shall have the meaning of programs and data written in machine code.

Using the software indicates your acceptance of this license agreement. If you do not accept these license terms, you are not authorized to use this software.

**Programs of Third Parties** Programs of third parties are all programs which constitute part of the System and/or its options at the time of delivery to the Customer but have not been developed by Studer. The following conditions are applicable to programs of third parties:

- The right to use third parties’ programs is governed by the License Agreement attached hereto (if applicable), which is an integral part of this Agreement. The Customer shall sign any and all License Agreements for all further programs of third parties installed on the system. The Customer shall be deemed to have received all License Agreements upon delivery of the system and/or its options.
- Studer shall accept no responsibility or liability for, and gives no warranties (express or implied) as to the programs of third parties. The Customer waives any and all claims versus Studer for any consequential damages, which might occur due to defects of these programs.

### Right of Use

---

**Principle** Studer grants the Customer the non-exclusive right to use the License Material in one copy on the system and/or its options as laid down by the Sales Agreement concluded between the parties and all Terms and Conditions which shall be deemed to form and be read and construed as part of the Sales Agreement. This right is assignable according to the ‘Assignability’ paragraph hereinafter.

**Customized Configurations** The Customer is not entitled to alter or develop further the License Material except within the expressly permitted configuration possibilities given by the software installed on the system or elsewhere. All altered programs, including but not limited to the products altered within the permitted configuration possibilities, are covered by this License Agreement.

**Reverse Engineering** Reverse engineering is only permitted with the express consent of Studer. The consent of Studer can be obtained but is not limited to the case in which the interface software can not be provided by Studer. In any case Studer has to be informed immediately upon complete or partial reverse engineering.

**Copying the License Material** The Customer is entitled to make one copy of all or parts of the License Material as is necessary for the use according to this Agreement, namely for backup purposes. The Customer shall apply the copyright of Studer found on the License Material onto all copies made by him. Records shall be kept by the Customer regarding the amount of copies made and their place of keeping. The responsibility for the original program and all copies made lies with the Customer. Studer is entitled to check these records on first request. Copies not needed anymore have to be destroyed immediately.

**Disclosure of License Material** The License Material is a business secret of Studer. The Customer shall not hand out or in any way give access to parts of or the complete License Material to third parties nor to publish any part of the License Material without prior written consent of Studer. The Customer shall protect the License Material and any copies made according to the paragraph above by appropriate defense measures against unauthorized access. This obligation of non-disclosure is a perpetual obligation.

Third parties are entitled to have access to the License Material if they use the License Material at the Customer's site in compliance with this Agreement. Under no circumstance are third parties entitled to have access to the installation software on the original data media. The Customer shall safeguard the original data media accordingly.

**Assignability** The rights granted to the Customer according to this License Agreement shall only be assignable to a third party together with the transfer of the system and/or its options and after the prior written consent of Studer.

## **Rights to License Material**

---

With the exception of the right of use granted by this License Agreement all proprietary rights to the License Material, especially the ownership and the intellectual property rights (such as but not limited to patents and copyright) remain with Studer even if alterations, customized changes or amendments have been made to the License Material.

Studer's proprietary rights are acknowledged by the Customer. The Customer shall undertake no infringements and make no claims of any patent, registered design, copyright, trade mark or trade name, or other intellectual property right.

## **Warranty, Disclaimer, and Liability**

---

For all issues not covered herewithin, refer to the 'General Terms and Conditions of Sales and Delivery' being part of the sales contract.



**VISTA FX**

**1 Introduction.....3**

**2 Hardware.....4**

**3 Setup with SCoreLive.....6**

3.1 Hardware setup .....6

3.2 Network configuration.....7

3.3 Files on the Vista control PC .....7

3.4 Files on the redundant Vista control PC .....8

3.5 Setup process in Vista application .....8

3.6 Startup.....10

**4 Effect routing ..... 11**

**5 Operation.....13**

5.1 Engine setup .....13

5.2 General Patch.....15

5.3 Create Send Return Effects.....18

5.4 Create Insert Effects .....20

5.5 Loading Effects.....22

5.6 Effect parameters .....24

5.6.1 Halls, Plates and Chambers.....24

5.6.2 Rooms .....27

5.6.3 Environments .....29

5.6.4 Chorus / Flange .....29

5.6.5 Delay .....29

5.6.6 Resonance .....31

5.6.7 Reverse.....31

5.6.8 Pitch Shift.....32

5.6.9 Pitch Effects .....32

5.6.10 Tap Control.....33

5.7 Copy/Paste .....33

5.8 Snapshot operation .....35

5.8.1 Snapshots and Presets .....35

5.8.2 Static Automation.....35

5.9 Dynamic automation.....37

5.10 Offline operation.....37

**6 Preset Overview .....38**

**7 Specifications.....39**



## 1 INTRODUCTION

### Legendary Lexicon® Reverbs and Effects

Software V4.9 allows to have highest quality multi-effect units deeply integrated into the Vista mixing system.

Multi-effect units are useful for any mixing application, but most importantly for sound reinforcement and live broadcast productions. In general, multi-effect units provide effects processing for the most commonly used time based effects, such as : Reverb, Flange/Chorus and Delay. Studer Vista FX is the result of a collaboration between Studer and Lexicon, which provides broadcast quality effects-processing, controlled from the intuitive Vistonics interface of the Vista console.

The processing is carried out in Vista FX DSP units which are linked to the SCoreLive. These hardware units are based on the legendary Lexicon PCM96 Surround DSP-platform, and therefore provide all PCM96 Surround effect preset categories :

- Hall & Random Hall
- Concert Hall
- Plate
- Chamber
- Room
- Dual Delay
- Random Delay
- Chorus / Flange
- Resonant Chords
- Reverse
- Pitch Shift

#### **Vista with SCoreLive**

The Vista FX units are optional hardware units which can either be part of a newly ordered mixing system, or they can be added to any existing Vista mixing system which is based on the SCoreLive DSP engine.

#### **Vista with Performa Core**

Vista mixing system based on the older Performa DSP engine cannot be equipped with Vista FX.

#### **Vista with Infinity Core**

Vista mixing systems based on the Infinity Core can make use of the original Lexicon PCM 96 Surround units to achieve the Vista FX functionality. Two Lexicon PCM 96 Surround units have the same FX resources as one Vista FX unit.

## 2 HARDWARE



The Vista FX hardware is coming in a housing which uses 2 RU in a 19" rack. It has the Studer partnumber **5003726**.

One such hardware unit is the equivalent of two Lexicon PCM96 "engines". Up to three such Vista FX units can be combined, to provide Lexicon effects in the equivalent of six Lexicon PCM96.

**Front LED's** The faceplate provides a green and a red LED for each of the redundant powersupplies, "Power1" and "Power2". The green LED indicates 'ok' state of the powersupply, the red LED indicates the 'fail' state, in case of a powersupply failure or in case of a loss of power.

**Connectors** On the rear of the unit the following connectivity is provided :

- 2x mains inlet with switches for redundant power supplies
- 8x RJ45 HD-Links for audio connection to the dsp engine as well as slave units.
- 4x RJ45 Ethernet Control Ports (A and B). Two of each for daisy chaining.

**Number of Slaves switch** A rotary switch allows to set the "Number of Slaves" (the number of additionally Vista FX units, connected to the "Master" unit). Range : **0..2**.

**Lock LED's** These LED's inform about the HD-Link Lock status of the audio connections. A solid illuminated LED means that the HD-Link is locked, and therefore the audio connection is established and ok. While the unit is booting and the audio connection is being established, the LED is flashing. When the LED stays dark, no connection is established or the Lock status has been lost. (e.g. due to the connected unit being powered down, or an error in the HD-Link connection).

**Core/Master LED** - Status of the HD-Link to the DSP Core

**Slave1 LED** - Status of the HD-Link to the first Vista FX slave unit

**Slave2 LED** - Status of the HD-Link to the second Vista FX slave unit

**Slave3 LED** - currently not used.

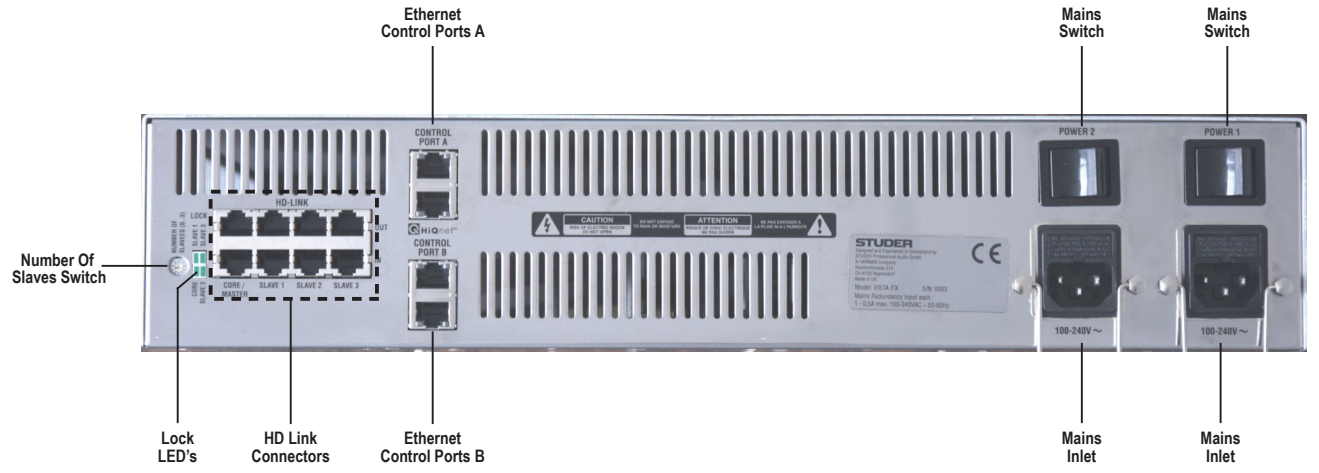

## 3 SETUP WITH SCORELIVE

### 3.1 Hardware setup

**Necessary connections** There are two types of connections that need to be established :

- Audio connections to the DSP Core
- Control connection to the Vista desk

**Audio connections** The audio connections are done by using the HD-Link ports of the first free DSP card. It is recommended to use the upper two RJ45 connectors – as they automatically detect the Vista FX hardware. Synchronising is automatically done through the HD-Link. In addition to the above cabling, it is also necessary to modify the DSP setup of the SCORELive : there need to be 48 input and output ports defined on the first DSP card that had no I/O allocated beforehand.

**Master Box Setup** Connect the „Core/Master“ IN and OUT of the master box with the HD-Link ports of the DSP card. Set the „Number of Slaves“ rotary switch to the number of connected slave FX boxes.

**Slave Box Setup** Connect the “Core/Master” IN and OUT of the Slave x box to the “Slave x” OUT and IN of the master box.  
“Number of Slaves” of Slave FX boxes must be set to 0.

**Control connection** The control connection to the desk is using Harman’s HiQNet protocol and needs a simple Ethernet connection.

**Setup** All control ports of all units need to be daisy-chained with CAT5 cables. The first or the last port then needs to be connected to the Vista desk.

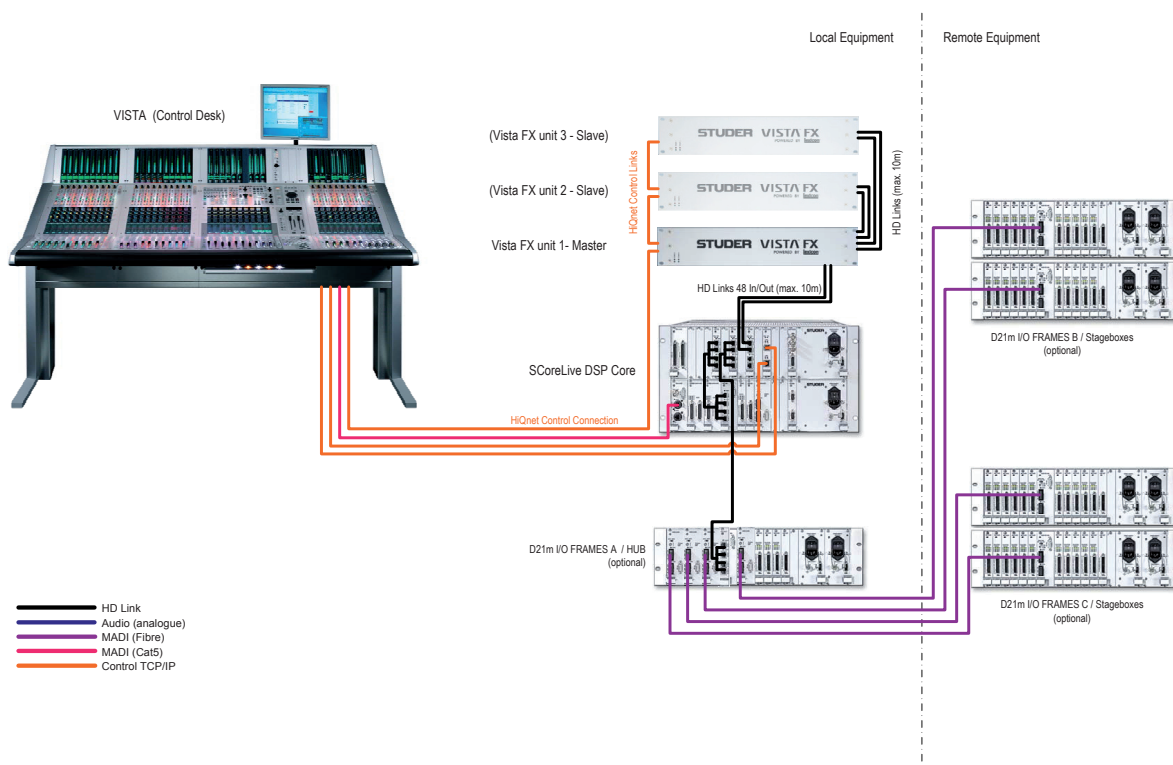

## 3.2 Network configuration

---

**Vista control PC requirements** We recommend using the subnet “xxx.xxx.3.xxx” on the used Vista network adapter by default for all Vista FX units.  
On some Vista systems (e.g. Vista 5) the subnet “xxx.xxx.3.xxx” does not yet exist. There, we recommend defining this additional subnet “xxx.xxx.3.xxx”. See note below on how to add a subnet.

**Add a subnet** This requires changes to the protected part of the operating system, so it is recommended that the windows operating system be restarted at this point. When the desk has rebooted with the Vista application closed:

- Open your secondary network adapter.
- Click Properties.
- Click Internet Protocol (TCP/IPv4) then click Properties. You should see the IP address 192.168.2.128 configured
- Click Advanced.
- On the IP Settings tab, click Add...
- Type in the new IP address (192.168.3.128 – subnet mask 255.255.255.0) then click Add.
- Click OK to close the Advanced TCP/IP settings window.
- Click OK to close the Internet Protocol (TCP/IP) Properties window.
- Click OK to close your network adapter properties window.

Please verify the added subnet settings.

In order to make these changes fixed when the desk is power cycled, the EWF system must be updated.



Do not share the same HiQNet connection with other desks having Vista FX units connected as the systems sees all Vista FX units found in the network as local hardware.



Do not connect the Vista FX units to a DHCP network. This will result in unstable connectivity of the Vista FX units.

## 3.3 Files on the Vista control PC

---

**FXConfiguration file:** The Vista desks D950System folder must contain two files :

**FXConfiguration.xml** and  
**FXConfiguration.xdr**.

If they are not available in there, they can be copied from the current SW version folder Vista/XML.

The ip address must be edited according to HiQnet entry in D950System.ini.

**D950System.ini file:** The HiQNet-node configuration in the D950system.ini file needs to be adapted.

[HiQnet]

Node=555 ← *this ID must be different on the redundant PC*  
 DhcpEnabled=No ← *must be set to "No"*  
 IpAddress=192.168.3.128 ← *this needs to be the used subnet*  
 ReconfigureDeviceInDiffSubnet=Yes ← *must be set to "Yes"*  
 ; old entries for compatibility  
 SubnetMask=255.255.255.0 ← *must be set to exact this value*  
 Gateway=0.0.0.0 ← *must be set to exact this value*  
 SerialNumber=001B214F13C6 ← *must be set to exact this value*

Make sure an "s" is added to the relevant DSP card serial port. e.g. if the Vista FX unit is connected to the DSP card in slot 4, the following entry is necessary :

[d950SerialPorts]

10= {s} TCP4 slot=4 ← *must be set to "s"*

The following entries define the DSP card slot number and HD-Link port number where the Vista FX units are connected to. The default entries are empty, allowing automatic discovery via D21m. These settings can also be used to configure Vista FX units being connected to the second HD-Link (port 1) of a DSP card, where no D21m communication can be used and therefore Vista FX units cannot be detected automatically. For Offline usage of Vista FX with e.g. a Virtual Vista where no Vista FX units have been connected before, manually entered numbers will enable to Vista SW to emulate the FX units.

[LexiconFX]

ConnectedDspCardSlot= ← *empty or 1-9*

ConnectedDspCardPort= ← *empty or 0-1*

### 3.4 Files on the redundant Vista control PC

On the redundant PC there must be an additional set of the two FXConfiguration.xml and FXConfiguration.xdr files in the D950System folder.

If both PCs share the same HiQNet subnet, then the files can be identical. This is the recommended setting for the redundant PC setup.



Make sure that the HiQNet node ID (555 is default) of the redundant PC is different to the main PC.

### 3.5 Setup process in Vista application

Setup Dialog in the Vista application : Once all the above is done correctly, the Vista application can be started and the "FX Audio Setup Dialog" can be run. This dialog is found in the System Administrator menu.



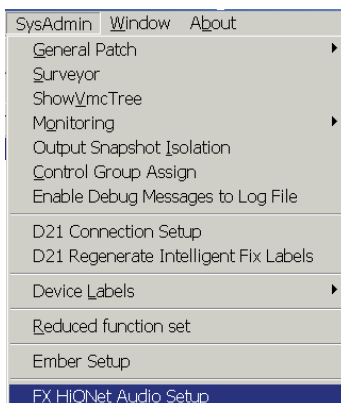

FX Audio Setup Dialog Menu

The FXAudioHiQNetSetup – window opens up, and the “Start Setup” button can be pressed.

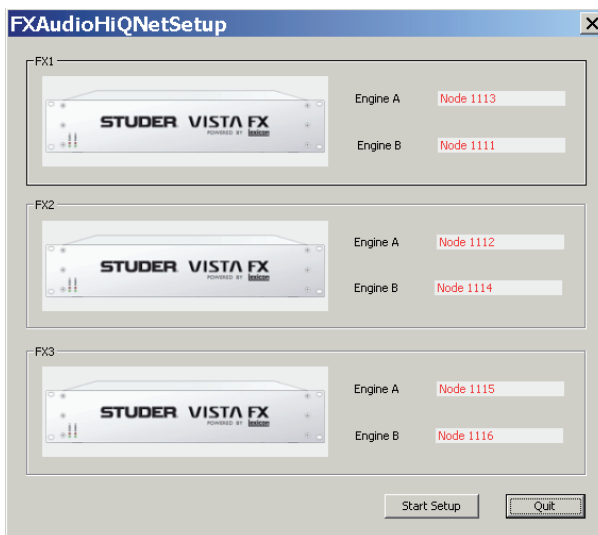

Setup Window

Then all the connected Vista FX hardware units are detected and become available for the Vista mixing system. This is then displayed in the Surveyor window :

Surveyor View

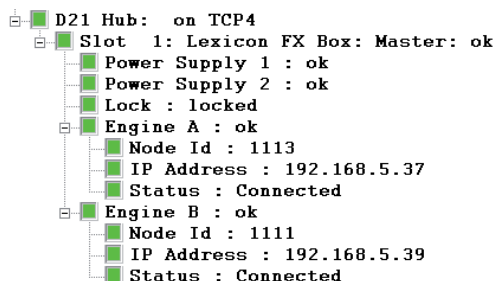

When there is any change in the IP configuration, the system prompts to ask the user to run the Audio Setup Dialog again.

## 3.6 Startup

---

Please note that all the above setup process needs to be done only once, as the initial setup. From then on, the Vista mixing system will always provide the FX, every time the system is started.

Start-up time of the Vista FX unit

During the power up of the Vista FX hardware unit, its lock LEDs of the active HD link connections are flashing. It takes about two minutes for the unit to become operational. A successful start-up and lock situation is indicated with a steady ON of the Lock LED.

## 4 EFFECT ROUTING

The Lexicon PCM96 Surround provides the categories of effects presets as mentioned in chapter 1. The routing of these effect-blocks can vary in terms of number of inputs and outputs. This can then allow a number of effects to be processed simultaneously on the same unit. In the PCM 96 Surround, the effects can also be cascaded, leading to the following variety of possible routings :

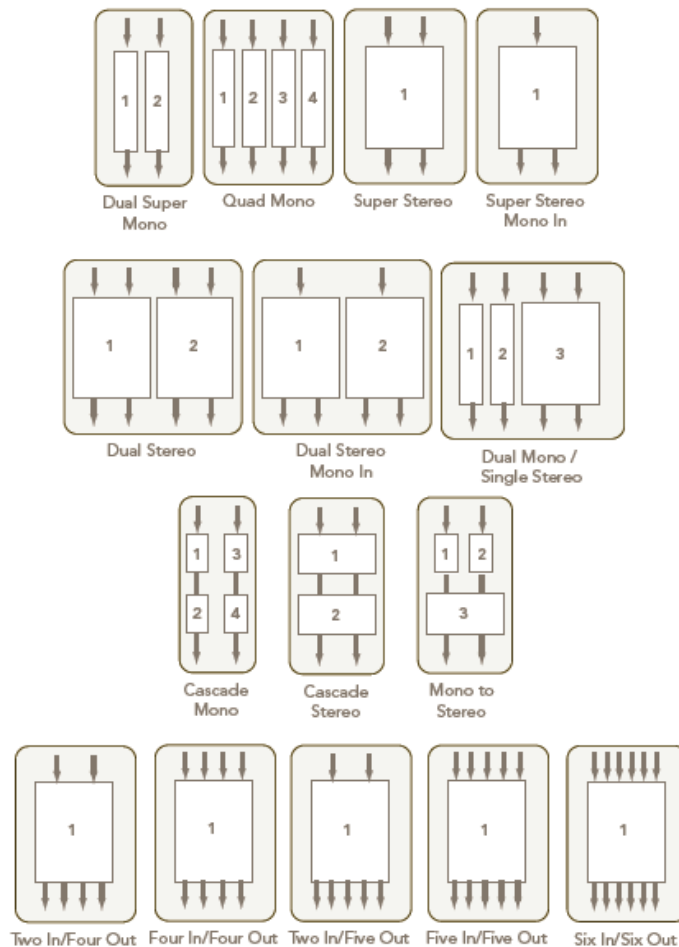

With the operating philosophy in the Vista consoles, only a subset of these routing possibilities are available for Vista FX. These are :

- **Dual Stereo**
- **Quad Mono**
- **Single Two In Five Out**
- **Single Five In Five Out**
- **Single Six In Six Out**

Once the structures of the effects engines are defined, their inputs as well as outputs are available in the general patch of the Vista consoles GC.

To make working with Vista FX as easy and straightforward as possible, Vista FX are intended to be used in two ways :

### Send-Return Effects

This is the effect structure that has been used in the analog world with traditional outboard effects - using an Aux bus to add signal from several channels, and then feed it from the Aux to one single effect unit. To get the 'wet'-only

effect signal back into the mix, an input channel (“effect-return”) has to be used.

Since this is still a practical way of working, and because many operators are very familiar with this concept, it is also used for Vista FX.

**Insert Effects**

When an effect is only used for one single channel, it can be patched into the channels insert path. The effect then cannot be used for any other channels.

These two effect concepts can be used with Vista FX, and are explained in more details in the following chapter.

## 5 OPERATION

As oposed to the initial setup process, which is described above - here, the actual operation with Vista FX is explained.

### 5.1 Engine setup

As the starting point for working on a session by session basis with Vista FX, the engine setup needs to be carried out.



By pressing the **FX** button, the Vista FX Engine Setup window opens up.

The Vista FX Engine Setup window has three tabs : **FX1**, **FX2**, **FX3**  
 Each tab is representing one Vista FX hardware unit.  
 Every unit has two engines : **Engine A** and **Engine B**, each engine being one PCM96 Surround processing board.

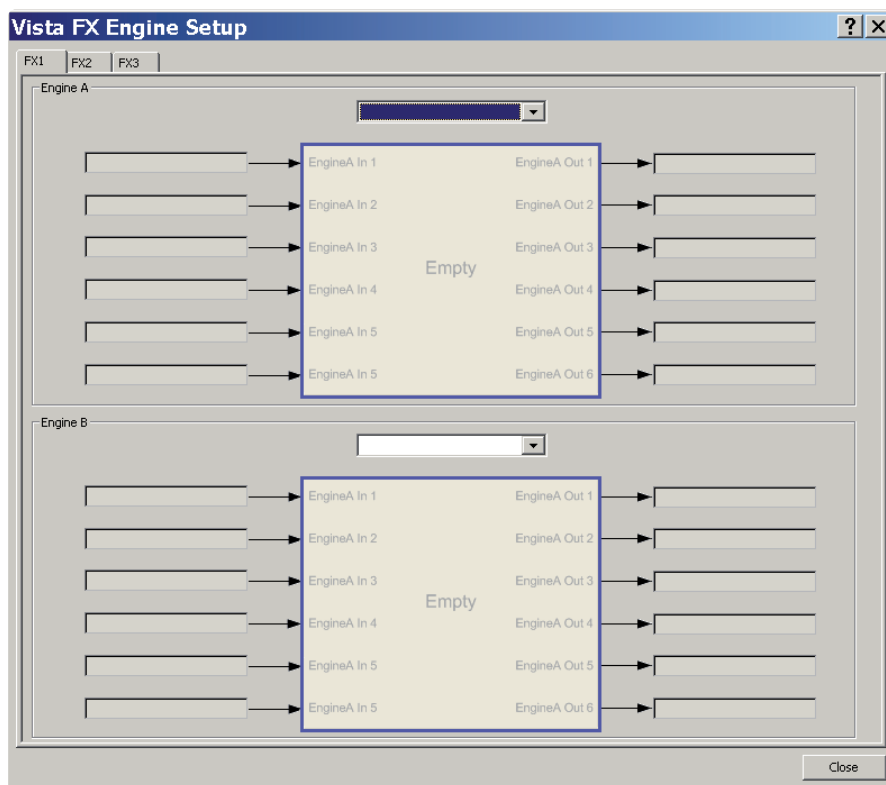

Clicking on the pull-down menu, the choice of engine setups is presented, and one can be chosen to be applied into the desired engine.

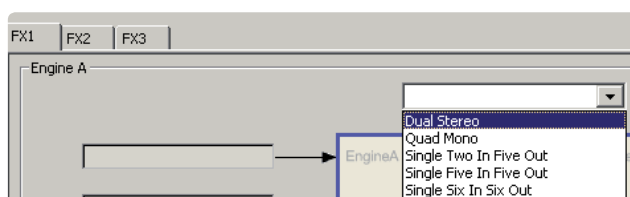

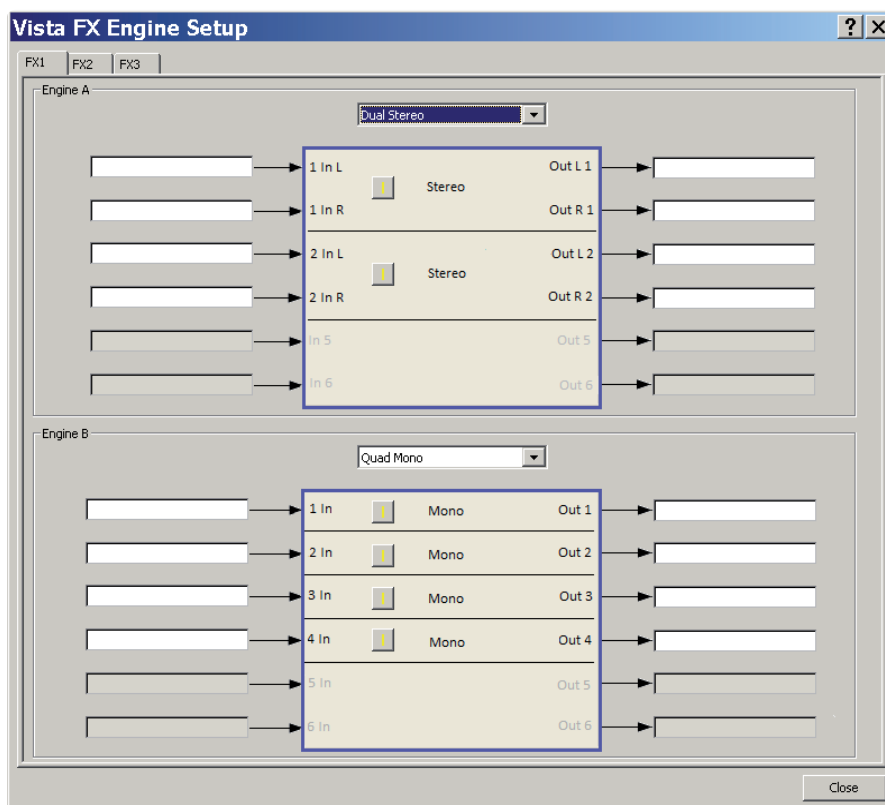

**Dual Stereo** setup : This setup provides two stereo effect blocks for one engine. It is suitable for usage of a stereo effect, e.g. a stereo reverb. Since two engines are available, the user has the benefit of running two different stereo effects at the same time. The stereo effect then can be used as a send-return effect, or also as an insert effect for a stereo channel.

**Quad Mono** setup : This provides four mono effect blocks for one engine. It is the preferred choice when using insert effects for mono channels. With both engines in this setup, up to eight insert effects can be provided. Of course, also the combination of different setups within one hardware unit is possible (see screenshot above).

**Single Two In Five Out** setup : This setup can be used to create a five channel surround effect with a simple stereo signal as the source. A nice way to create 5.1 ambiance for a stereo track.

**Single Five In Five Out** setup : This setup allows to create real surround effects. A 5.0 surround input signal will create a 5.0 effect signal.

**Single Six In Six Out** setup : For this setup only pitch shift effects can be loaded to treat a 5.1 signal in terms of pitch. For surround reverbs it is recommended to use the **Single Five In Five Out** setup.

When the setup procedure has been done for all available engines - or for at least all the engines which are required in the current project - the necessary input- and output ports are ready to be used in the general patch page. (They are not greyed out anymore).

**Note :** The engine setup is the base setup on which all later selected effects are loaded. So changing the engine setup after effects have already been worked

with will reset all effects and they will need to be reloaded again!  
 There is a warning window which informs about the consequences that the changing of the engine setup will have :

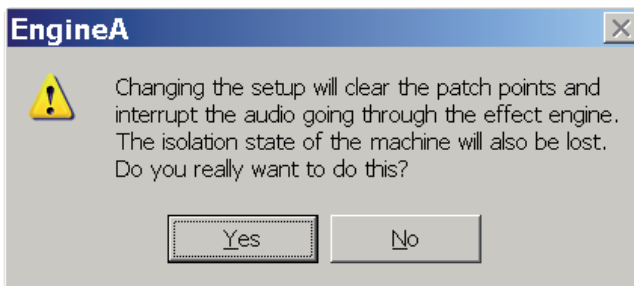

**Note :** Also the state of the engine setup is stored in snapshots. This means that the engine setup can be changed by recalling a previously created snapshot.

## 5.2 General Patch

On the general patch page (**General Patch**), there are additional sources and target categories where the effect input- and output ports can be found.

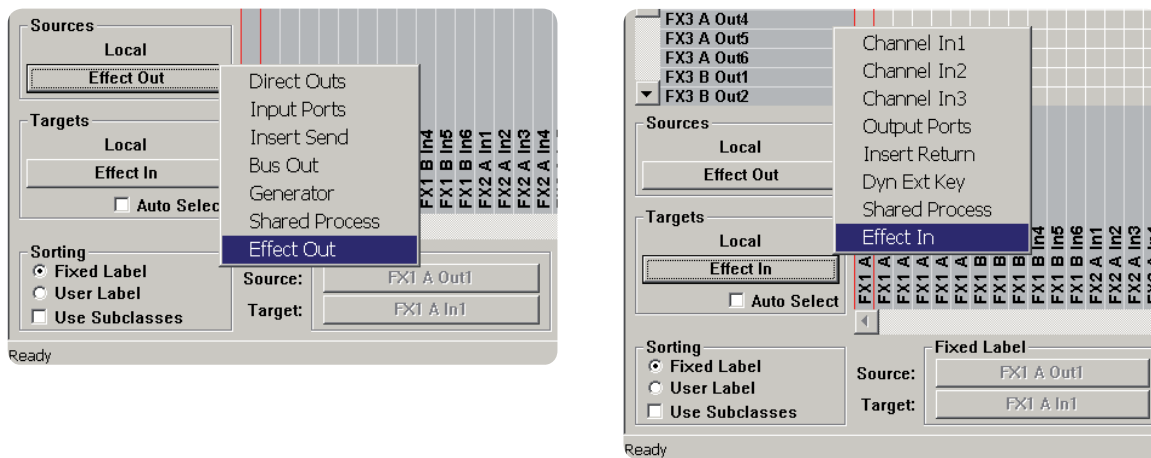

As long as *no* setup is loaded in the Engine Setup window, all effect input- and output ports are greyed out.

**Note :** When the ports are greyed out, no patch connections can be made !

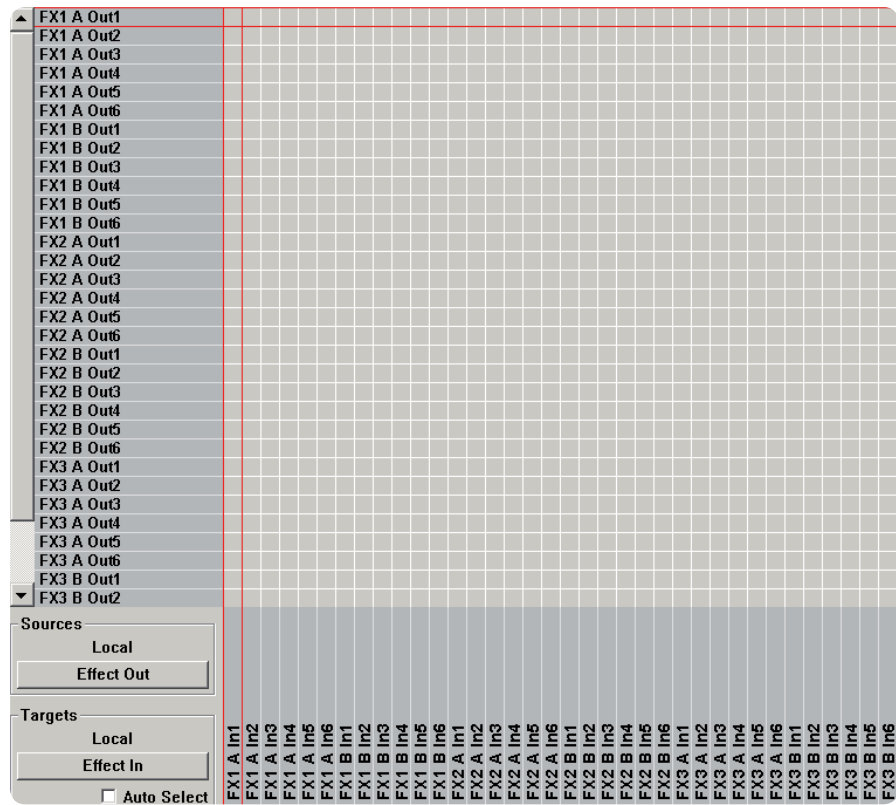

The general patch always shows six input- as well as output ports per engine. Because up to three Vista FX hardware units can be connected, and each hardware unit has two engines, the total of shown patch points is always 36 input- and 36 output ports.

(6 ports x 2 engines x 3 hardware units = 36 patch points).

After one or several setup's have been loaded, the respective input- and output ports become available and are ready to be patched. These ports are then not greyed out anymore.

**Dual Stereo** setup : For example, it can be seen that when loading a “**Dual Stereo**” setup into **Engine A** of the **FX1** hardware unit, the first four output ports become available for use. They are also labelled according to the **Dual Stereo** setup :

FX1 A Out1 M1 L
FX1 A Out2 M1 R
FX1 A Out3 M2 L
FX1 A Out4 M2 R
FX1 A Out5
FX1 A Out6

Also the input ports become available for patching and are labeled for the **Dual Stereo** setup :





window :

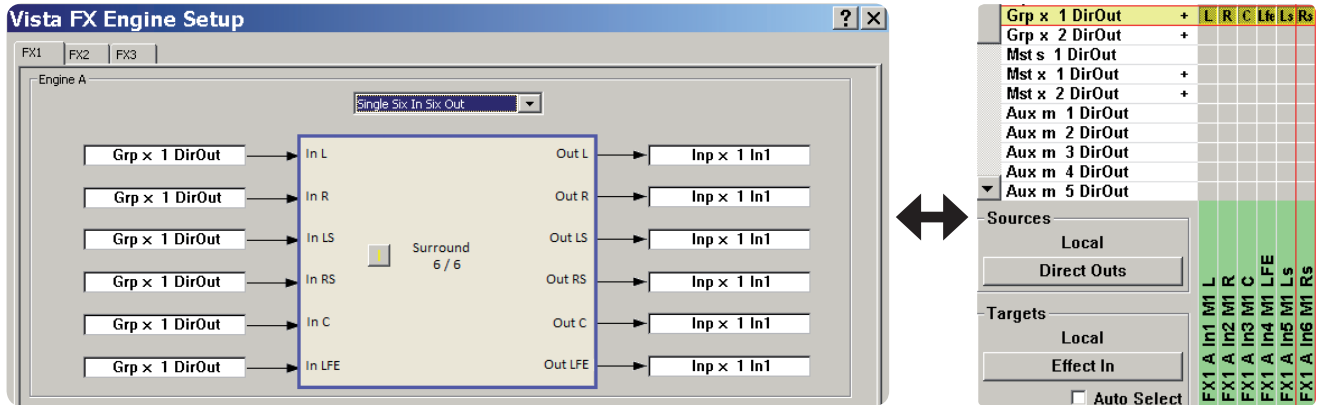

As a shortcut for ‘patching to effect targets’ and ‘from effect sources’, it is also possible to doubleclick into one of the twelve label areas in the setup window. This then navigates directly to the general patch, to the desired target or source.

### 5.3 Create Send Return Effects

To setup the desk for working with a ‘Send-Return’ effect, a few steps of preparation need to be carried out :

1. Patch the Direct Out of the desired Aux master to the effect input port.

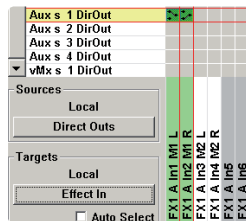

This will change the colour of the Aux send icons as well as the Aux master to blue. This is to indicate that the chosen Aux bus is used as an effect send.



2. Patch the effect out port to the desired return channel (input channel).

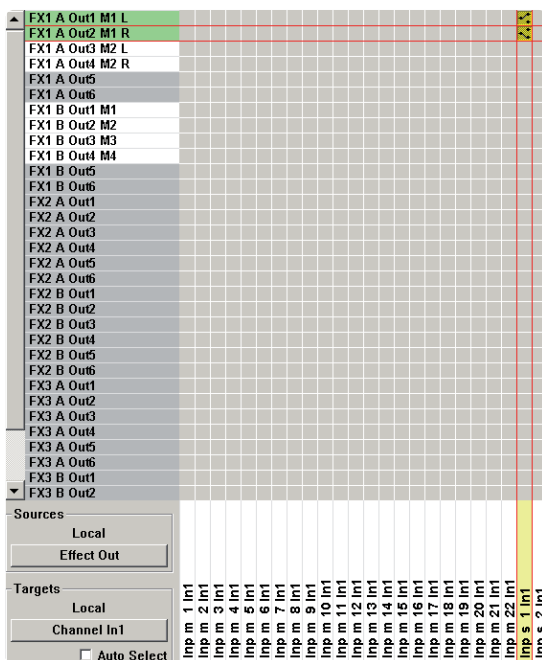

This return channel then gets the blue FX icon instead of the panning icon in the Vistonics touch area (the panning can still be done in the channel ‘misc’ view).

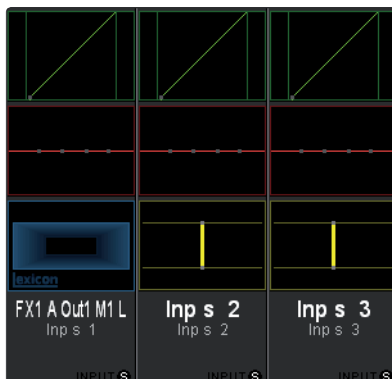

3. Make the desired bus assign for the return channel
4. Operate the FX parameters from the FX icon in the Vistonics touch area.
5. Use Filters and EQ as well as Dynamics of the return channel to further process the effect sound to taste.

These steps can be repeated for as many ‘Send-Return’ effects as needed for the current title. It is also a good idea to have such setup already as a part of the generic console setup - e.g. stored in a preset or snapshot.

## 5.4 Create Insert Effects

To setup the desk for working with an 'Insert' effect, the following steps of preparation need to be carried out :

1. Patch the effect output port and effect input port into the insert path of the desired channel - either on general patch or easier on channel patch page.

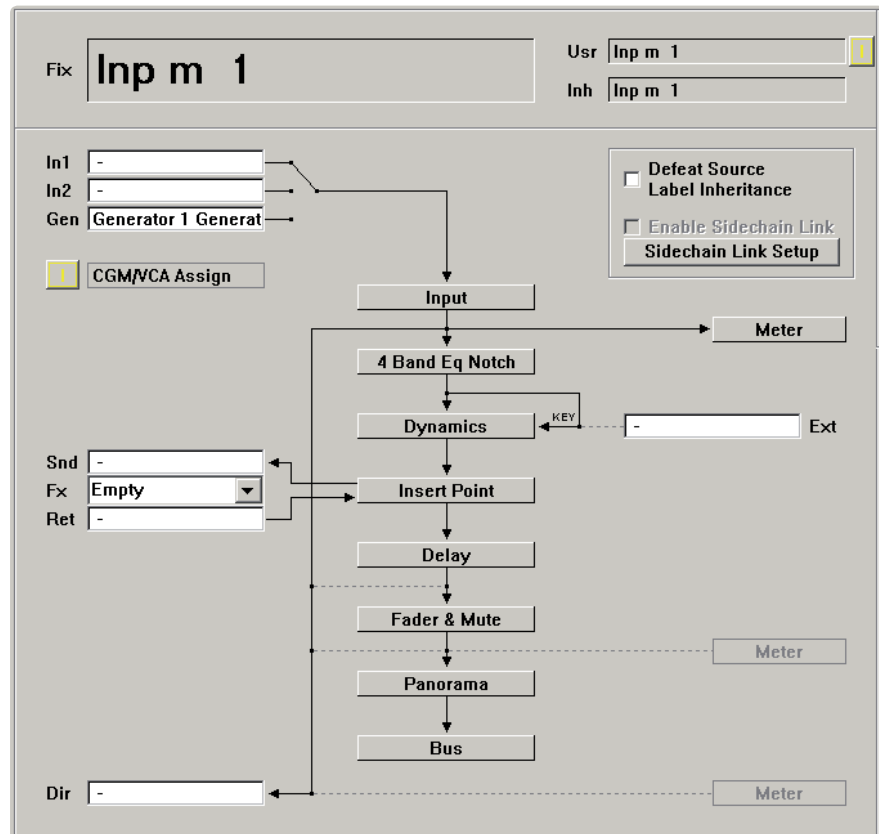

On the channel patch page : only the desired FX block needs to be chosen from the pull-down menu, patching is then done automatically. The pull-down menu shows all FX blocks which are not used yet, and which fit the channel width (mono. stereo, surround) of the channel.

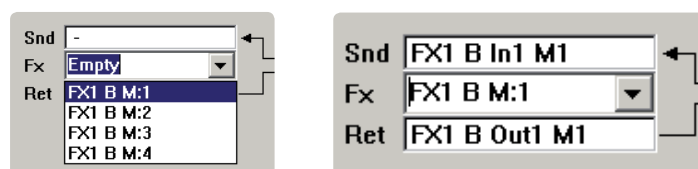

The patching, which is carried out automatically, will then show as follows :

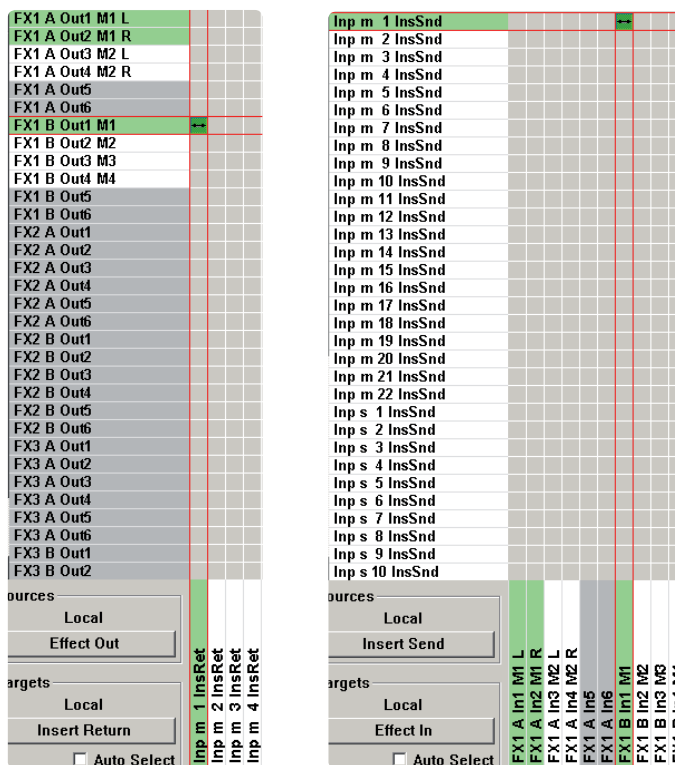

This channel then gets the blue FX icon instead of the panning icon in the Viconics touch area (the panning can still be done in the channel ‘misc’ view).

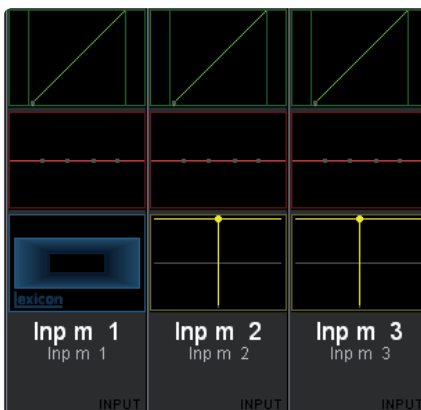

2. Operate the FX parameters from the FX icon in the Viconics touch area.
3. Activate the channels **Insert On/Off**.
4. Use the effects wet/dry **Mix** parameter to blend the processed signal to the dry signal to get the desired resulting sound.

## 5.5 Loading Effects

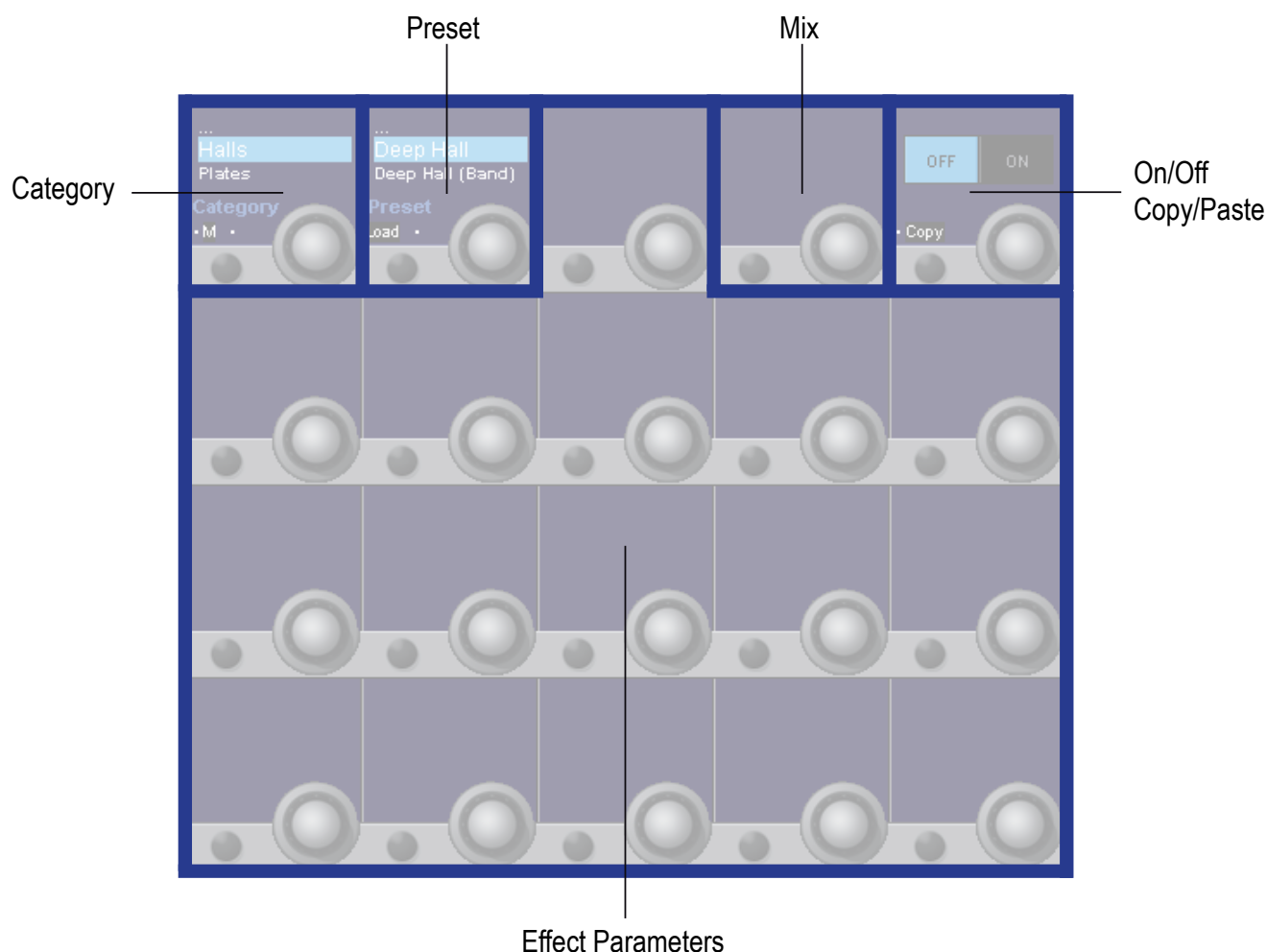

When touching into the FX icon area of the Vistronics, a number of blue coloured Vistronics rotaries and icon areas are opened up. This area is always 5 x 4 Vistronics rotaries wide. It is divided into the following areas :

**Category :** The Vista FX presets are grouped into categories. Each category has its own set of presets. Category is describing the 'type' of the effect. On all reverb effects, the categories are further divided into small, medium or large size.

**S** : small

**M** : medium

**L** : Large

The size can be toggled-through with the Vistronics button.

**Preset :** Presets are defined Lexicon factory presets, which can only be loaded. Presets cannot be stored as user presets - as is normally possible with standalone effect units.

When effect parameters are adapted to the users needs - they can be stored within a snapshot. Presets always remain as they originally have been designed by Lexicon. Once any of the presets parameters has been changed , the **Load** button is changed and becomes a **Clear** button. By pressing **Clear**, all parameters are cleared back to the original preset values.

- Mix :** Adjusts the proportion of wet (processed) signal to dry (unprocessed) signal. Ranges from 0% (all dry) to 100% (all wet). With send-return effects, you will leave this at 100% wet, and with insert-effects, the desired dry/wet blend can be created.
- On/Off - Copy/Paste :** Here, the effect processing of the engine is globally switched **On** or **Off**. Please note, that the default state of the processing is **Off** !  
The small Vistonics button has the function of a copy/paste button. With the copy/paste button, effect settings can be copied from effect engine to engine - or into the clipboard library.
- Effect Parameters :** In this area, all effect parameters are displayed and can be controlled from the Vistonics rotaries and buttons.  
(Please note that a maximum of 16 parameters can be used. Some of the original Lexicon effects have more than 16 parameters, in this case STUDER has made the choice of the 16 most important parameters - which then can be controlled.)
- Loading a preset : To load a **Preset**, first the effect **Category** has to be chosen. With all reverberation effect categories, also the choice of the space size can be made. This is done with the Vistonics element on the left side.  
With the second Vistonics element, the preset can be chosen. The list of presets which are available in the chosen category can be scrolled through with the rotary. Once the desired preset has been found, it can be loaded by pressing the **Load** button.



As soon as a preset is loaded, it's control parameters are shown on the Vistonics area. If the user then scrolls further through the preset list, the parameters disappear again, but they will come back when the preset loaded before (now marked with an asteriks in front of the name \*) is brought into the highlighted area :



This is because the loaded preset remains loaded and is running, only until a different preset is loaded by pressing the **Load** button.

The same behaviour applies for the **Category** control.

## 5.6 Effect parameters

---

Please note that per preset, a maximum of 16 parameters can be controlled on the Vistonics user interface. Some of the original Lexicon effects have more than 16 parameters, in this case STUDER has made the choice of the 16 most important parameters - which then can be controlled.

**On/Off :** Switches the effect processing On and Off.

**Mix :** Allows to blend the unprocessed signal with the processed effect signal. Range [0 .. 100] %

These two parameters are available for all effect presets.

### 5.6.1 Halls, Plates and Chambers

---

For the categories

#### **Halls, Plates and Chambers**

the following parameters are available :

**Predelay :** This is a delay that is added to the diffused signal before it enters the main part of the reverb. For all intents, it may be considered as delay that is added to the reverberated signal. It is used to temporally separate the reverb from the dry signal. Range [0 .. 1000] ms.

**Reverb Time :** This is the reverb decay time. The range is depending on the Room Size parameter. Range [0.11 .. 210] s.

**Reverb Out Frequency :** The late reverb signal is filtered by a one pole low-pass. This is the filters cutoff frequency. Range [50 .. 20'000] Hz.

**Front Reverb Frequency :** The front portion of the late reverb signal is filtered by a one pole low-pass. This is the filters cutoff frequency. Range [50 .. 20'000] Hz. *On surround engines only.*

**Back Reverb Frequency :** The back portion of the late reverb signal is filtered by a one pole low-pass. This is the filters cutoff frequency. Range [50 .. 20'000] Hz. *On surround engines only.*

**Center Reverb Frequency :** The center portion of the late reverb signal is filtered by a one pole low-pass. This is the filters cutoff frequency. Range [50 .. 20'000] Hz. *On surround engines only.*

**Diffusion :** Input diffusion is the first part of processing for any signal entering a reverb. It can be described as a smearing or softening of the signal and is typically used to lessen the impact of strong transients. Range [0 .. 100] %.

**Reverb Time HiCut :** This parameter, also known as Hicut or RTHC is a low-pass filter in the recirculating part of the reverb. It represents a frequency above which the tail dies away more quickly. In some ways, it represents the opposite end of the scale from BassRT, and may be considered an analog of air absorption. It is also closely tied to the Hi Cut Damping parameter. Range [50 .. 20'000] Hz.



- Bass RT :** This parameter controls bass reverb time. It is closely associated with the Bass Crossover parameter. BassRT applies to signal below the frequency described by Bass Crossover. If BassRT is less than 1.0, then the low frequency part of the reverb tail will be shorter than the midrange part. If BassRT is greater than 1.0, then the low frequency part of the tail is longer. Range [0.25 .. 4] multiplier.
- Tail Width :** The reverb tail (all components of the reverb except for early reflections, etc.) is passed through a simple 2x2 matrix. This provides an encoding of the tail that dramatically changes its spatial characteristics. The tail can be changed to feel narrower (even down to mono) or wider than normal stereo. There are values for the parameter to encode the tail in such a way that it decodes into surround channels.  
The parameter operates in the range of 0 to 360 degrees, with an incremental change of 1 degree. The matrix uses Sine/Cosine rules so that power distribution remains constant. This may be acceptable—even highly desirable—but the mix engineer must fully understand the process and its implications. This is a powerful tool for audio whose release format is two-channel. It is not useful in any other format. Formats include compact disc and radio/television broadcast. Some of these effects are clear and noticeable without any sort of decoder. Many are even more dramatic when a decoder is in place, such as in a home theater. Range [0 .. 360] degrees. *On stereo engines only.*
- Early Level :** This parameter acts as a master control for any early signals going to the output channels. Early signals include echoes, reflections, and the room reflection patterns. Range [Off .. 0.0] dB
- Bass Crossover :** The Bass Crossover parameter is closely tied to the BassRT parameter. It represents the frequency below which BassRT has an effect. Range [50 .. 10'000] Hz
- RtHC Damping :** The damping parameter is closely tied to the RTHC parameter. It controls the strength of the hi frequency absorption and has three values: Light, Normal, and Heavy. The normal value gives filter response identical to previous Lexicon® reverbs. The other values should be self-descriptive. Range [light, normal, heavy]
- Shape :** The Shape parameter is closely tied to the Spread parameter. Shape controls how energy is injected into the reverberator. A low value means that sound enters the reverb at the beginning of the spread window. A high value means that most sound moves into the reverb at the end of the spread window. A value somewhere in the middle means that sound enters the reverb evenly across the spread window. Range [0 .. 64]
- Room Size :** Room Size corresponds roughly to the length of the longest wall of a rectangular room. In a more general sense, it corresponds to the overall dimension of some mythical space. This space has a geometry that causes sound to bounce around. When the room size is small, the “walls” of this space are closer together and the resultant reflection density increases. When the room size is large, that density decreases. The most natural reverbs use room sizes that vary from about 24 meters to 45 meters or so, but there are many useful reverbs that are outside of this range. Range [2.0 .. 80.0] m

**Reverb Level :** This parameter acts as a master control for reverb signals going to the output channels. Range [Off .. 0.0] dB

**Spread :** The spread parameter is closely tied to the Shape parameter. Spread is a window of time during which a signal is injected into the reverb. Shape controls just how the signal is injected during this window. Range [0 .. 100] %

**Reflection Time Master :** Controls all reflection delays in the algorithm. Each reflection delay voice has its nominal delay time adjusted by this percentage. Range [0 .. 100] %

## 5.6.2 Rooms

---

For the category

### Rooms

the following parameters are available :

- Reverb Time :** This is the reverb decay time. The range is depending on the Room Size parameter. Range [0.11 .. 210] s.
- Room Size :** Room Size corresponds roughly to the length of the longest wall of a rectangular room. In a more general sense, it corresponds to the overall dimension of some mythical space. This space has a geometry that causes sound to bounce around. When the room size is small, the “walls” of this space are closer together and the resultant reflection density increases. When the room size is large, that density decreases. The most natural reverbs use room sizes that vary from about 24 meters to 45 meters or so, but there are many useful reverbs that are outside of this range. Range [2.0 .. 80.0] m
- Predelay :** This is a delay that is added to the diffused signal before it enters the main part of the reverb. For all intents, it may be considered as delay that is added to the reverberated signal. It is used to temporally separate the reverb from the dry signal. Range [0 .. 1000] ms.
- Diffusion :** Input diffusion is the first part of processing for any signal entering a reverb. It can be described as a smearing or softening of the signal and is typically used to lessen the impact of strong transients. Range [0 .. 100] %.
- Front Frequency :** The front portion of the late reverb signal is filtered by a one pole low-pass. This is the filters cutoff frequency. Range [50 .. 20'000] Hz. *On surround engines only.*
- Back Frequency :** The back portion of the late reverb signal is filtered by a one pole low-pass. This is the filters cutoff frequency. Range [50 .. 20'000] Hz. *On surround engines only.*
- Early Scale :** This parameter is used to modify the overall time of the selected early impulse. It is a multiplier that goes from 0.5x to 2.0x. The actual time of the responses varies from response to response. The Early Scale parameter simply scales that amount of time. It's fair to describe this a “rubber-banding” the impulse response. Range [0.5 .. 2.0] multiplier.
- Early Crossover :** The Early (Bass) Crossover parameter is closely tied to the Early Bass Boost parameter. It represents the frequency below which Early Bass Boost has an effect. Range [50 .. 10'000] Hz. *On mono and surround engines only.*
- Pattern Category :** This parameter lets you select a specific category from which a room response may be chosen. Changes here have a direct effect on the Pattern Selector parameter. Range [Small, Medium, Large, Exteriors, Odd, Artificial]
- Pattern :** Selects a space available in the selected Category. Range [various spaces]
- Early Level :** This parameter acts as a master control for any early signals going to the output channels. Early signals include echoes, reflections, and the room reflection

patterns. Range [Off .. 0.0] dB. *On mono and stereo engines only.*

- Reverb Level :** This parameter acts as a master control for reverb signals going to the output channels. Range [Off .. 0.0] dB. *On mono and stereo engines only.*
- RtHC Damping :** The damping parameter is closely tied to the RTHC parameter. It controls the strength of the hi frequency absorption and has three values: Light, Normal, and Heavy. The normal value gives filter response identical to previous Lexicon® reverbs. The other values should be self-descriptive. Range [light, normal, heavy]. *On stereo engines only.*
- Early Frequency :** The early reflection signal is filtered by a one pole low-pass. This is the filters cutoff frequency. Range [50 .. 20'000] Hz. *On mono engines only.*
- Early Bass Boost :** This parameter is closely tied to the Early Crossover parameter. It controls the boost (or cut) of signal below that crossover. Range [-12.0 .. +12.0] dB
- Tail Width :** The reverb tail (all components of the reverb except for early reflections, etc.) is passed through a simple 2x2 matrix. This provides an encoding of the tail that dramatically changes its spatial characteristics. The tail can be changed to feel narrower (even down to mono) or wider than normal stereo. There are values for the parameter to encode the tail in such a way that it decodes into surround channels.  
The parameter operates in the range of 0 to 360 degrees, with an incremental change of 1 degree. The matrix uses Sine/Cosine rules so that power distribution remains constant. This may be acceptable—even highly desirable—but the mix engineer must fully understand the process and its implications.  
This is a powerful tool for audio whose release format is two-channel. It is not useful in any other format. Formats include compact disc and radio/television broadcast. Some of these effects are clear and noticeable without any sort of decoder. Many are even more dramatic when a decoder is in place, such as in a home theater. Range [0 .. 360] degrees. *On stereo engines only.*
- Reverse :** Reverses the impulse response of the room. Range [On .. Off]. *On mono and stereo engines only.*

### 5.6.3 Environments

---

For the category  
**Environmens**  
a subset of the **Halls**, **Rooms** and **Delay** parameters are available.

### 5.6.4 Chorus / Flange

---

For the category  
**Chorus / Flange**  
the following parameters are available.

- Delay Level :** Controls all delays in the algorithm. Each voice has its nominal gain value adjusted by this percentage. [0 .. 100] %
- Delay Feedback :** Controls all delays in the algorithm. Each voice has its nominal feedback gain adjusted by this percentage. Range [0 .. 100] %.
- Delay Time :** Controls all delays in the algorithm. Each voice has its nominal delay time adjusted by this percentage. Range [0 .. 100] %
- LFO Rate :** Sets the speed of an LFO. Range [0.01 .. 10.0] Hz
- LFO Waveform Type :** Sets the shape of the wave the LFO will follow. Range [various waveforms].  
*On stereo and surround engines only.*
- Voice Delay Wander :** This parameter determines the amount of additional delay that the LFO process can add to a voice's offset. Range [0.0 .. 1000] ms. *On surround engines only.*
- Mst Diffusion :** Input diffusion is the first part of processing for any signal entering a delay. It can be described as a smearing or softening of the signal and is typically used to lessen the impact of strong transients. Range [0 .. 100] %.

### 5.6.5 Delay

---

For the category  
**Delay**  
the first few presets use a subset of the **Halls** parameters, all other presets have the following parameters :

- Delay Time :** Controls all delays in the algorithm. Each voice has its nominal delay time adjusted by this percentage. Range [0 .. 100] %
- Voice Delay :** Delay time of Voice 1. Range [0 .. 9500] ms
- Voice FB :** This parameter determines the feedback level for a particular voice. It is controlled independently of the voice's output level. Range [0.0 INV .. Off .. 0.0] dB
- Delay Level :** Controls all delays in the algorithm. Each voice has its nominal gain value adjusted by this percentage. [0 .. 100] %

- Voice 1 Frequency :** The delay voice output signal is filtered by a one pole low-pass. This is the filters cutoff frequency Range [50 .. 20'000] Hz
- Voice 1 FB :** The feedback signal is filtered by a one pole low-pass. This is the filters cutoff frequency Range [50 .. 20'000] Hz
- Mst Diffusion :** Input diffusion is the first part of processing for any signal entering a delay. It can be described as a smearing or softening of the signal and is typically used to lessen the impact of strong transients. Range [0 .. 100] %.
- FB Diffusion :** Feedback Diffusion is similar to Input Diffusion, except that it is applied to a delayed signal that is being added back into the input. Range [0 .. 100] %.
- LFO Rate :** Sets the speed of an LFO. Range [0.01 .. 10.0] Hz
- Delay Feedback :** Controls all delays in the algorithm. Each voice has its nominal feedback gain adjusted by this percentage. Range [0 .. 100] %.
- Tapping :** Assigns the Tap control to one of the **USR** buttons on the consoles channel strip. Range [No, USR1, USR2]

### 5.6.6 Resonance

---

For the category  
**Resonance (Resonant Chords)**  
the following parameters are available.

- Delay Level :** Controls all delays in the algorithm. Each voice has its nominal gain value adjusted by this percentage. [0 .. 100] %
- Delay Feedback :** Controls all delays in the algorithm. Each voice has its nominal feedback gain adjusted by this percentage. Range [0 .. 100] %.
- Delay Time :** Controls all delays in the algorithm. Each voice has its nominal delay time adjusted by this percentage. Range [0 .. 100] %
- Resonance Master :** Controls all voices in the algorithm. Each voice has its nominal resonance adjusted by this percentage. Range [0 .. 100] %
- Resonance Frequency :** This parameter determines at which frequency the delay voice resonates. Range [C0 .. B7] music note. *On mono engines only.*

### 5.6.7 Reverse

---

For the category  
**Reverse**  
the parameters of the Room category are available, with one additional parameter :

- Reverb Shelf :** This parameter allows a certain amount of unfiltered audio to be combined with the filtered audio. This effectively lowers the effect of the filter. Another way of looking at it is that it lessens the normal filter slope of 12 dB per octave. Range [Off .. 0.0] dB. *On mono and stereo engines only.*

### 5.6.8 Pitch Shift

---

For the category  
**Pitch Shift**  
 the following parameters are available.

- Pitch Shift :** This parameter determines the amount of positive or negative pitch shift for the shift. Expressed in semitones. Range [-12.0 .. 12.0] smt.
- Pitch Trim :** This parameter detunes the pitch shift established by the Shift Semi or Pitch Shift parameters. Range [-50.0 .. 50.0] cnt
- XFade Time :** This is used to control the crossfade time of the splice. In general a short crossfade is desirable, but more complex material may need longer crossfade times. Range [2.0 .. 15.0] ms
- Lowest Shift Frequency :** This tells the shifter the lowest frequency that it may be required to shift. As a general rule of thumb, this should be set in the higher part of the range in order to preserve detail in the shifted material. It should be lowered if artifacts appear in the low frequencies. Range [20.0 .. 250] Hz
- Smart Shift :** This tells the shifter to use smart (content-based) pitch shift or blind shift. In most cases, 'smart' is the better choice. Range [ On .. Off]

### 5.6.9 Pitch Effects

---

For the category  
**Pitch Effects**  
 the following parameters are available.

- Delay Time :** Controls all delays in the algorithm. Each voice has its nominal delay time adjusted by this percentage. Range [0 .. 100] %
- Pitch Shift :** This parameter determines the amount of positive or negative pitch shift for the shift. Expressed as a percentage. Range [0 .. 100] %
- Delay Feedback :** Controls all delays in the algorithm. Each voice has its nominal feedback gain adjusted by this percentage. Range [0 .. 100] %.
- Mst Diffusion :** Input diffusion is the first part of processing for any signal entering a delay. It can be described as a smearing or softening of the signal and is typically used to lessen the impact of strong transients. Range [0 .. 100] %. *On stereo and surround engines only.*
- Delay Level :** Controls all delays in the algorithm. Each voice has its nominal gain value adjusted by this percentage. [0 .. 100] %. *On stereo engines only.*
- Voice Frequency :** The delay voice output signal is filtered by a one pole low-pass. This is the filters cutoff frequency Range [50 .. 20'000] Hz. *On stereo and surround engines only.*
- FB Diffusion :** Feedback Diffusion is similar to Input Diffusion, except that it is applied to a delayed signal that is being added back into the input. Range [0 .. 100] %. *On surround engines only.*



### 5.6.10 Tap Control

On the category **Delay**, the presets **Simple Mono Delay (T)** and **Simple Stereo Delay (T)** are also providing an assignable Tap control.

**Tapping :** Assigns the Tap control to one of the **USR** buttons on the consoles channel strip. Range [No, USR1, USR2]

By choosing **USR1** or **USR2**, the Tap control can be done with either of the two user buttons on the consoles channel strip, above the fader. The button can then be tapped in order to configure the resulting delay time. As an optical feedback, the button is blinking with the configured time intervall.

## 5.7 Copy/Paste

With the **Copy** button, the current preset, with its current parameter settings is being copied into the clipboard. As now the clipboard library window opens up automatically, the settings can be pasted into the clipboard library.



As an alternative, the settings can also be copied into a channel which is also assigned to an effect. To achieve this, the **Paste** button can be used.



**Clipboard Library** The clipboard library has been extended by a new tap called **FX**. Here all effect library entries are stored.

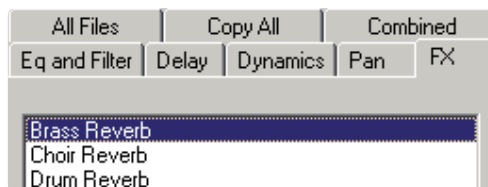

Also a new clipboard library button has been implemented - the copy button next to it can be used to copy library entries into the clipboard, and then into a the desired channel.



**Note :** Effect settings can only be copied within the same engine setup format (mono, stereo, surround) !  
The paste function will only be carried out when the target channel has the same engine format as the source channel, or the setting stored in the clipboard library.  
If the format is not matching, the settings are not pasted into the target channel. No error message is displayed - the system will just be ready for a new copy/paste operation.

---

## 5.8 Snapshot operation

---

### 5.8.1 Snapshots and Presets

---

All necessary settings to recreate any use of Vista FX can be stored in snapshots. In more detail, the following data is stored within each snapshot or system preset :

- \* the engine setup
- \* patching of the effect input- and output ports
- \* choice of preset
- \* effect parameter settings of the current state

**Note :** The recalling of a snapshot or a preset can change the Vista FX engine setup if this snapshot had been previously stored with a different engine setup.

In such a case where the engine setup is changed by a snapshot, unsaved effect parameter settings can then be overwritten.

Therefore it is important to keep in mind that the engine setup is of great importance and should be set-up correctly at the start of a session and preferably not be changed anymore.

(Of course - a snapshot recall **undo** operation would bring back the unsaved settings if a snapshot had been recalled by error.)

**Important :** Manually changing the engine setup when the engine is in use, displays a warning window. When performing the same change via a snapshot recall - *no* warning window is displayed !

---

### 5.8.2 Static Automation

---

**Global Snapshot filter** With the global snapshot filter, effect parameters can be isolated as any other audio parameter in the system. This is done by editing the global snapshot filter, and then touching any of the to be isolated parameter controls. Please note that the isolation of **Category** and **Preset** parameters is always linked.

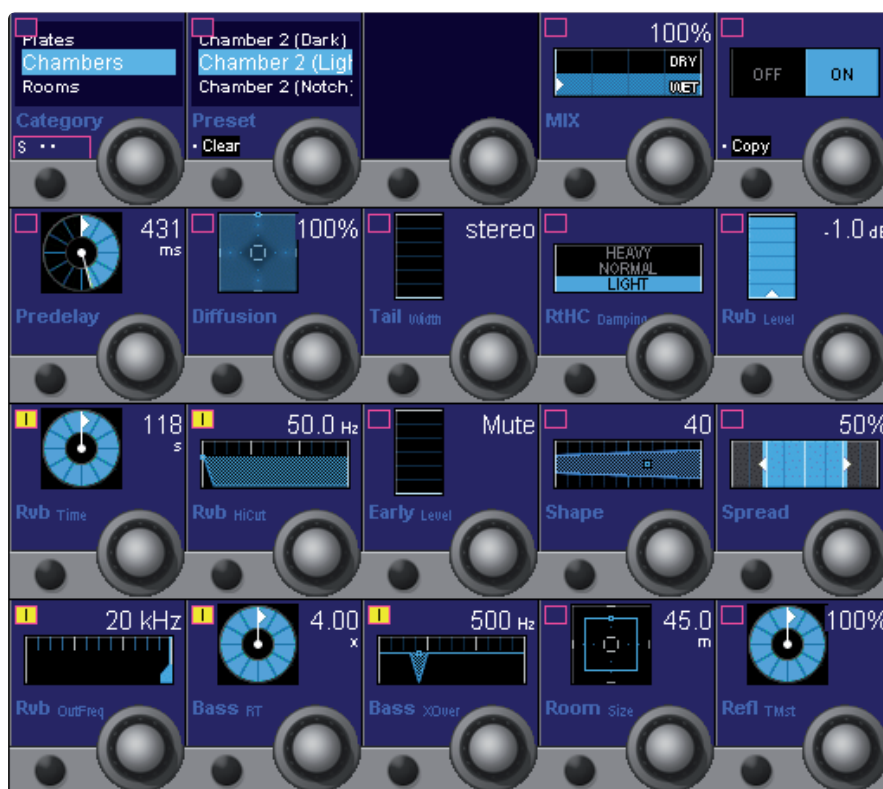

In addition to the effect parameters, also the engine setup - or parts thereof can be isolated. This can be done in the Vista FX engine setup window.

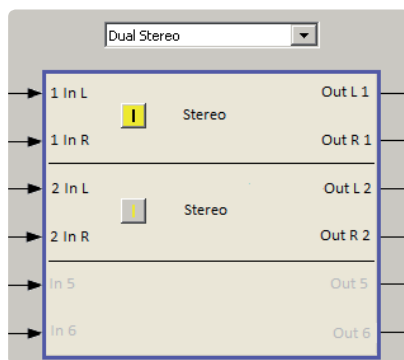

**Partial Snapshots** Effect parameters can be used in partial snapshots as any other audio parameter in the system. Please refer to [chapter 4.4.4](#) of the Vista operating instructions for more details.

**Trim :** Please note that as a difference to other audio parameters, effect parameters cannot make use of the **Trim** functionality in the static automation.

**CueList crossfades** Please note that as a difference to other audio parameters, effect parameters cannot make use of the crossfade functionality in the CueList.

## 5.9 Dynamic automation

---

Effect parameters can only be used in Static Automation mode. In the Dynamic Automation mode, effect parameters cannot be automated against timecode.

## 5.10 Offline operation

---

Without having FX connected to the desk, it is possible to configure FX and set its parameters using the Virtual Vista application. If FX boxes have been connected and recognized on the systems there are some entries automatically being written to the D950System.ini file defining the location (audio interfaces) of the connected FX hardware. If there was no FX hardware connected before, the following entries define the desired interfaces.

D950System.ini file :

[LexiconFX]

ConnectedDspCardslot=

( DSP card slot number where the FX units are connected to. Value: 1 default is empty (0) allowing automatic discovery via D21m).

ConnectedDspCardPort=

( DSP card port number where the FX units are connected to Value: 0 default is port 0 ).

There must be at least 48 inputs and outputs configured on the port being used for the FX connection.

This settings can also be used to configure FX hardware being connected to the second DSP card port which has no D21m communication and therefore cannot detect the FX boxes automatically.

## 6 PRESET OVERVIEW

This table provides an overview over the number of presets per category and per FX engine setup format.

Category	Size	Mono	Stereo	Surround		
				Two In Five Out	Five In Five Out	Six In Six Out
Halls	Small	50	68	86	86	-
	Medium	50	60	78	78	-
	Large	93	105	139	139	-
Plates	Small	30	30	37	37	-
	Medium	35	35	43	43	-
	Large	35	35	45	45	-
Chambers	Small	15	15	21	21	-
	Medium	31	31	37	37	-
	Large	20	30	26	26	-
Rooms	Small	56	56	76	76	-
	Medium	33	31	59	59	-
	Large	17	19	29	29	-
Environments	-	12	35	35	35	-
Chorus/Flange	-	17	37	34	34	-
Delay	-	15	29	27	27	-
Resonance	-	13	47	47	47	-
Reverse	-	21	21	21	21	-
Pitch Shift	-	4	8	12	12	12
Pitch Effects	-	8	25	42	42	-

## 7 SPECIFICATIONS

Supported Sampling Rates	Conditions / Details
44.1kHz, 48kHz, 88.2kHz, 96kHz	Clock signal provided from DSP engine via HD-Link connections - Vista FX unit is autolocking to the provided clock.

Ambient Conditions	Details	Value
Operating Temperature Range	see safety instructions	5 to 40 °C / 41 to 104 °F
Relative Humidity	see safety instructions	85%

Weight	Value
Vista FX unit	5.0 kg / 11.0 lbs

Redundant Power Supplies	Conditions / Details	Value
Input Voltage Range	Power supply auto-ranging, with power factor correction (PFC); EN/UL approved	100 to 240 V AC $\pm$ 10% 50 to 60 Hz
Power Consumption		25 W

Dimensions	Value
Width	48.26 cm / 19 in
Height	2 RU
Depth	39 cm / 15.35 in

