

The JBL logo is displayed in white on a red square background. It consists of the letters 'JBL' in a bold, sans-serif font, with a stylized 'J' that has a vertical bar on its left side.

PROFESSIONAL

VTX SERIES
SYSTEM SOLUTIONS

VTX B18 | User Manual

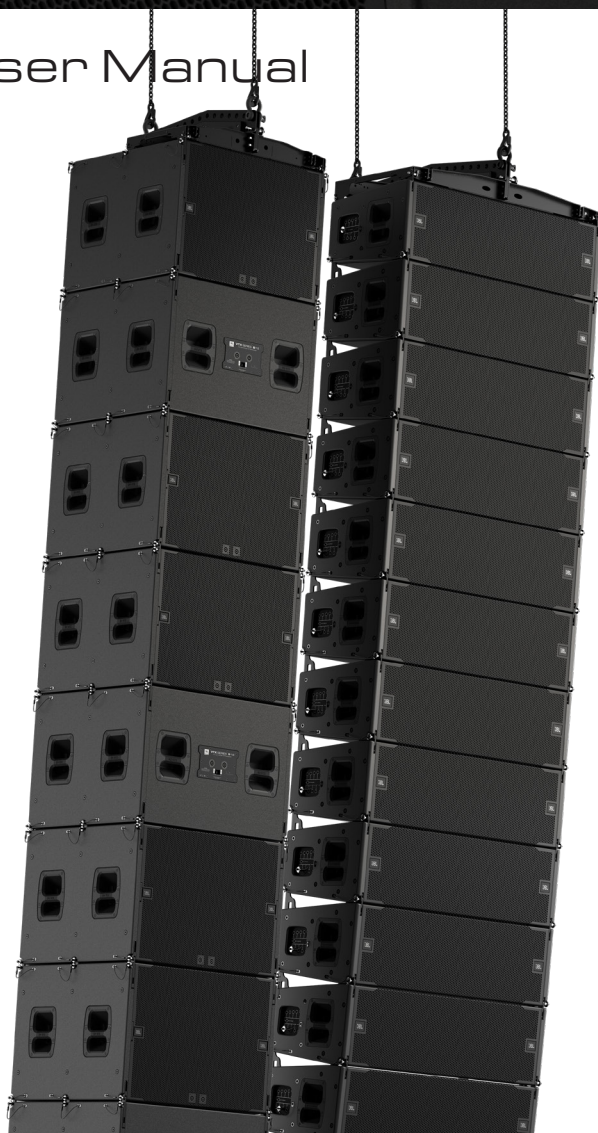

GENERAL INFORMATION

VTX B18 - User Manual

Document Number: 1000337285

Version: B - EN

Distribution Date: 01/05/2019

Copyright © 2018 by HARMAN International; all rights reserved

JBL PROFESSIONAL

8500 Balboa Blvd

Northridge, CA 91329

USA

Thank you for purchasing JBL VTX Series products



Of all the achievements JBL has made over the years, the VTX Series stands as a milestone in the practical application of creative engineering. The next generation in line arrays, VTX heralds a new era in performance, system integration and user friendliness. Supported by multiple patents in driver, waveguide and suspension technology, VTX is also supported by technologies from HARMAN Professional sister companies for amplification, DSP, control and system management. In addition to high-performance components, VTX is backed by JBL's engineering support — the human factor and technical tools that are key to the proper specification and configuration of the VTX system in any venue, anywhere in the world.

The VTX Series is a result of JBL's continued effort to deliver more powerful, more compact, lightweight and flexible sound reinforcement systems. Designed for portable and fixed-venue system operators alike, VTX features JBL's legendary sound quality coupled with the most advanced sound reinforcement technology and support available. As a member of the HARMAN group, we draw from the expertise and integration of the entire range of HARMAN Pro audio technologies. So, in addition to the best sound possible, VTX offers efficient and intuitive setup, tuning, networking and control to provide a truly professional and advanced system solution.

TABLE OF CONTENTS

1 - DECLARATION OF CONFORMITY	6
2 - SAFETY	7
2.1 - Safety Instructions	7
2.2 - General Hardware Information	7
2.3 - Important Safety Warning	7
2.4 - Inspection and Maintenance	8
2.5 - Attachment to Structures	8
2.6 - Symbols	9
3 - SYSTEM COMPONENTS	10
4 - COMPATIBLE ACCESSORIES	11
4.1 - VTX A8 AF - Array Frame	11
4.2 - VTX A8 AF EB - Array Frame Extension Bar	11
4.3 - VTX A8 MF - Mini Frame	11
4.4 - VTX A8 SB - Suspension Bar	12
4.5 - VTX B18 VT - Vertical Transporter	12
4.6 - VTX B18 VT CVR - Soft Cover	12
4.7 - VTX B18 ACC - Accessory Cover and Casterboard	12
4.8 - VTX RC500 - Rotating Clamp	13
5 - SOFTWARE	14
5.1 - Line Array Calculator 3™	14
5.2 - Array Link™	14
5.3 - Performance Manager™	14
6 - OVERVIEW	15
7 - CONNECTIONS	16
7.1 - Internal Wiring	16
8 - TRANSPORTATION OPTIONS	17
8.1 - Rotating the Dolly Tabs - For use with the ACC Dolly	18
9 - VTX B18 PRESET LIBRARY	20
9.1 - VTX B18 Preset Modes and Options	20
9.2 - Time Alignment	20
10 - SYSTEM AMPLIFICATION & WIRING	21
10.1 - B18 Using Crown I-Tech 12000HD	21
10.2 - B18 Using Crown I-Tech 12000HD (Cardioid)	22
10.3 - B18 Using I-Tech 4x3500HD	23

10.4 - B18 Using I-Tech 4x3500HD (Cardioid)	24
10.5 - Crown Audio V-Rack	24
11 - CARDIOID CONFIGURATIONS	25
11.1 - Ground Stacked Cardioid Configurations	26
11.2 - Minimum space between Cardioid Stacks	27
11.3 - Minimum space from a Wall	27
11.4 - Cardioid Vs Omni - SPL Differences	28
12 - FLOWN CARDIOID CONFIGURATIONS	29
12.1 - Array Configurations	29
13 - CARDIOID PRESETS IN PERFORMANCE MANAGER	31
13 - ELECTRONIC DELAY STEERING (EDS)	32
13.1 - EDS Example - No Delays	32
13.2 - EDS Example - With Delays	33
14 - TESTING VTX B18	34
14.1 - Using a DMM (Digital Multi Meter)	34
14.2 - Using Performance Manager	35
14.3 - Performance Manager Readings	35
15 - SPECIFICATIONS	36
15.1 - VTX B18	36
16 - ACOUSTIC MEASUREMENTS	37
17 - DIMENSIONS	37
18 - CONTACT INFORMATION	38

1 - DECLARATION OF CONFORMITY

BRAND: JBL Professional

FAMILY NAME: VTX A8/B18 loudspeaker and suspension accessories

MODEL NAMES:

- **VTX B18**
- **VTX B18 VT**
- **VTX B18 ACC**
- **VTX A8 AF**
- **VTX A8 AF EB**
- **VTX A8 SB**
- **VTX A8 MF**
- **VTX RC500**

We, **HARMAN International**, declare under our sole responsibility that the product, to which this declaration relates, is in conformity with the following standards:

STANDARD	DESCRIPTION	TEST AGENCY
2006/42/EC MACHINE DIRECTIVE	Applies to machinery and lays down essential health and safety requirements ISO12100	Tested at JBL Professional
2014/35/EC LOW VOLTAGE DIRECTIVE	Applies to loudspeaker and lays down essential health and safety requirements. EN60065	Tested at JBL Professional



Frank Lacelle

Compliance Manager - Harman International

2 - SAFETY

Before using a JBL VTX Series system, please review the following for important information on safety and protection of your investment.

2.1 - SAFETY INSTRUCTIONS

1. Read these instructions
2. Keep these instructions
3. Heed all warnings
4. Follow all instructions
5. Do not expose the product to direct rain or sea spray
6. Clean only with a dry cloth
7. Do not install near any heat sources such as radiators, heat registers, stoves, or other apparatus that produce heat
8. Only use attachments / accessories specified by the manufacturer
9. Use only with a cart, stand, tripod, bracket, or table specified by the manufacturer or sold with the apparatus. When a cart is used, use caution when moving the cart / apparatus combination to avoid injury from tip-over
10. Refer all servicing to qualified service personnel. Servicing is required when the apparatus has been damaged in any way, such as liquid has been spilled or objects have fallen into the apparatus, the apparatus has been exposed to rain or moisture, does not operate normally, or has been dropped
11. Contact JBL Professional for advanced servicing issues
12. CAUTION - DO NOT PERFORM ANY SERVICING UNLESS YOU ARE QUALIFIED TO DO SO
13. **Prolonged exposure to excessive SPL can cause hearing damage:** the loudspeaker is easily capable of generating sound pressure levels (SPL) sufficient to cause permanent hearing damage to performers, production crew and audience members. Caution should be taken to avoid prolonged exposure to SPL in excess of 90 dB
14. Read the System Rigging Manual before installation and use of the product

2.2 - GENERAL HARDWARE INFORMATION

Any hardware used in an overhead suspension application must be load rated for the intended use. Generally, this type of hardware is available from rigging supply houses, industrial supply catalogs and specialized rigging distributors. Local hardware stores do not usually stock these products. Hardware that is intended for overhead suspension will comply with ASME B30.20 and will be manufactured under product traceability controls. Compliant hardware will be referenced with a working load limit (WLL) and a traceability code.

2.3 - IMPORTANT SAFETY WARNING

The information in this section has been assembled from recognized engineering data and is intended for informational purposes only. None of the information in this section should be used without first obtaining competent advice with respect to applicability to a given circumstance. None of the information presented herein is intended as a representation or warranty on the part of JBL. Anyone making use of this information assumes all liability arising from such use.

All information presented herein is based upon materials and practices common to North America and may not directly apply to other countries because of differing material dimensions, specifications and/or local regulations. Users in other countries should consult with appropriate engineering and regulatory authorities for specific guidelines.

Correct use of all included hardware is required for secure system suspension. Careful calculations should always be performed to ensure that all components are used within their working load limits before the array is suspended. Never exceed the maximum recommended load ratings.

Before suspending any speaker system always inspect all components (enclosure, rigging frames, pins, eyebolts, track fittings, etc.) for cracks, deformations, corrosion or missing/loose/damaged parts that could reduce strength and safety of the array. Do not suspend the speaker until the proper corrective action has been taken. Use only load-rated hardware when suspending JBL suspendable loud-speaker models.

2.4 - INSPECTION AND MAINTENANCE

Suspension systems are comprised of mechanical devices and, as such, they require regular inspection and routine maintenance to ensure proper functionality. Before suspending or pole mounting any speaker system, always inspect all components (enclosure, suspension frames or brackets, pins, eyebolts, etc.) for cracks, deformations, corrosion or missing/loose/damaged parts that could reduce strength and safety of the array. Do not suspend or pole mount the speaker until the proper corrective action has been taken.

Installed systems should be inspected at least annually. The inspection shall include a visual survey of all corners and load-bearing surfaces for signs of cracking, water damage, de-lamination or any other condition that may decrease the strength of the loudspeaker enclosure.

Accessory suspension hardware provided with or for VTX systems must be inspected for fatigue at least annually or as required by local ordinance. The inspection shall include a visual survey of the material for signs of corrosion, bending or any other condition that may decrease the strength of the fastener. Additionally, any eyebolts shall be checked for possible spin-out of the enclosure.

For all other hardware and fittings, refer to the hardware manufacturer's inspection and maintenance guidelines for process.

JBL is not responsible for the application of its products for any purpose or the misuse of this information for any purpose. Furthermore, JBL is not responsible for the abuse of its products caused by avoiding compliance with inspection and maintenance procedures or any other abuse.

Prior to suspending the system, an expert, trained and experienced in suspending speaker systems, should inspect all parts and components.

2.5 - ATTACHMENT TO STRUCTURES

A licensed Professional Engineer must approve the placement and method of attachment to the structure prior to the installation of any overhead object. The following performance standards should be provided to the Professional Engineer for design purposes: Uniform Building Code as applicable, Municipal Building Code as applicable and Seismic Code as applicable. The installation of the hardware and method of attachment must be carried out in the manner specified by the Professional Engineer. Improper installation may result in damage, injury or death.

2.6 - SYMBOLS

The following set of symbols are used in this document:



CAUTION: This symbol gives notice of a potential risk of harm to the individual or the equipment. Instruction marked with this symbol must be strictly followed.



TIP: This symbol gives notice of helpful, relevant information about the topic.



INSTRUCTIONS: This symbol gives notice of instructions that must be followed for proper installation and use of the product.



TOOLS REQUIRED: This symbol gives notice of tools that must be used for proper installation and use of the product.

3 - SYSTEM COMPONENTS

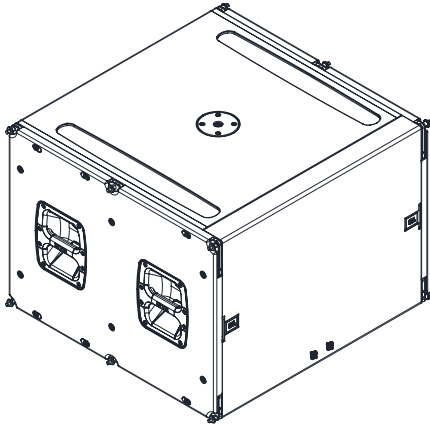

VTX B18

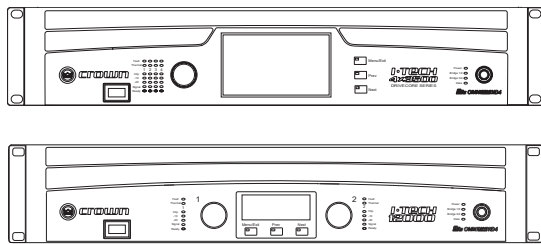

Crown I-Tech HD Amplifiers

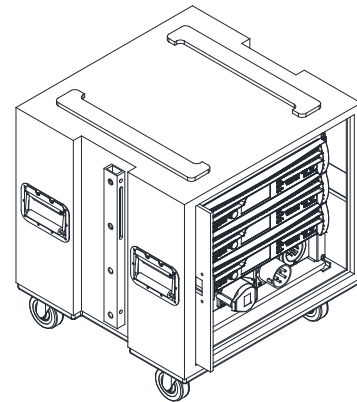

Crown Audio V-Rack

4 - COMPATIBLE ACCESSORIES

The accessories listed below are compatible with the VTX B18. For more detailed information about the B18 accessories refer to the VTX B18 Rigging manuals found at www.JBLpro.com.

4.1 - VTX A8 AF - ARRAY FRAME

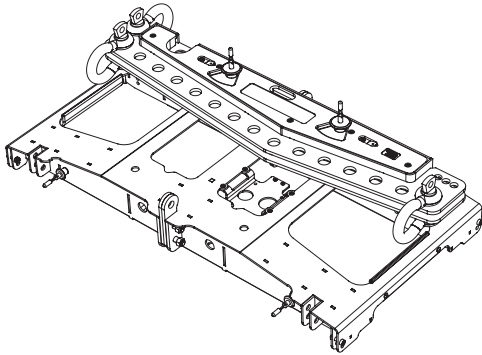

- Compatible with VTX A8 and VTX B18
- Maximum Limit: 24 x VTX A8 / 13 x VTX B18
- 0.5° pick-point resolution
- Built-in storage position for extension bar
- Includes 1 x VTX A8 AF EB extension bar
- Support for 3rd-party laser inclinometers
- Compatible shackle size: 5/8"

4.2 - VTX A8 AFEB - ARRAY FRAME EXTENSION BAR

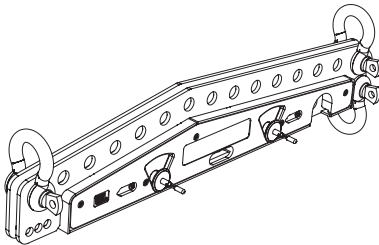

- Extension Bar for use with VTX A8 AF
- Single, front-to-back or side-by-side pick point options
- Includes 3 x shackles and mounting brackets
- Compatible shackle size: 5/8"

4.3 - VTX A8 MF - MINI FRAME

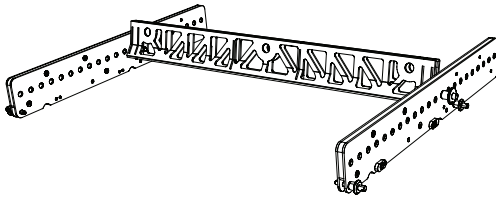

- Compatible with VTX A8 and VTX B18 enclosures
- Maximum Limit: 10 x VTX A8 / 4 x VTX B18
- Single-point and side-by-side pick-point options
- 3-part collapsible design
- Compatible shackle size: 1/2"

4.4 - VTX A8 SB - SUSPENSION BAR

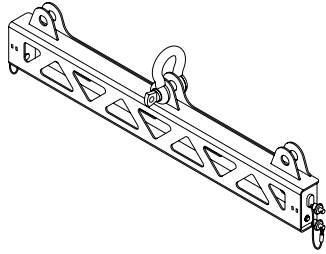

- Compatible with VTX A8 and VTX B18
- Maximum Limit: 24 x VTX A8 / 16 x VTX B18
- Used for pull-back applications
- Shackle Size: 5/8"

4.5 - VTX B18 VT - VERTICAL TRANSPORTER

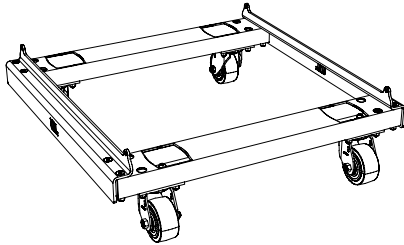

- Vertical transport cart for 2 - 4 VTX B18 subwoofers
- Truck-friendly dimensions
- Built-in stacking features for easy storage
- Lightweight design
- Heavy-duty casters

4.6 - VTX B18 VT CVR - SOFT COVER

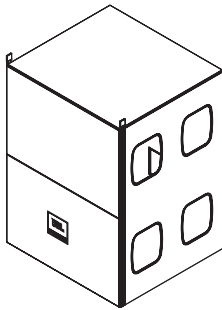

- Heavy-duty soft cover for VTX B18 enclosures
- Covers 2 or 3 x VTX B18 enclosures
- Includes input-panel flaps for testing purposes
- Clear see-through pocket for shipping label
- Handle cutouts for easy transportation
- Heavy-duty industrial-grade zippers

4.7 - VTX B18 ACC - ACCESSORY COVER AND CASTERBOARD

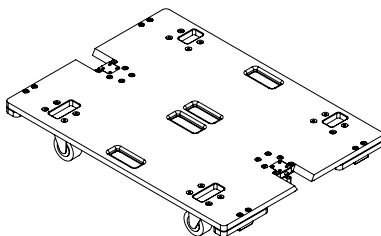

- Front face dolly and cover for VTX B18
- Cover includes handle cutouts and rear panel access flap
- Tour grade casters
- Stackable for convenient storage
- Rotating release/lock cam mechanisms for secure attachment to B18 enclosures

4.8 - VTX RC500 - ROTATING CLAMP

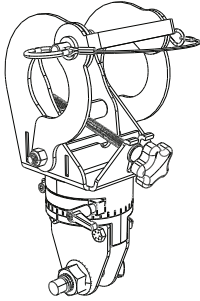

- Universal truss/pipe clamp adapter
- Working Load Limit: 500 kg (1100 lbs)
- Adjustable clamping mechanism
- Pipe range: 1" – 2.0"
- Includes bearing for smooth 360° rotation
- 10° rotation marks for horizontal array aiming



TIP: For B18 specific accessories refer to the VTX B18 User and Rigging manuals found at www.JBLpro.com.



CAUTION: Always use components and accessories specified and approved by JBL Professional. When a cart is used, use caution when moving the cart to avoid injury from tip-over.

5 - SOFTWARE

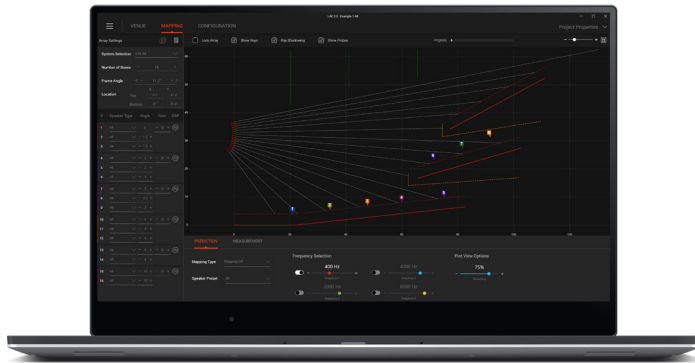

5.1 - LINE ARRAY CALCULATOR 3™

LAC is a simulation software for designing and predicting JBL VTX Series systems. LAC predicts the acoustical performance of line array systems, as well as flown and ground stacked subwoofer arrays. Subwoofer delay values can be generated for electronic delay steering (EDS) using the built-in coverage calculator. Beyond the acoustical prediction, LAC is used for mechanical validation of all used hardware and calculating weight limits and safety warnings.

www.jblpro.com/lac3

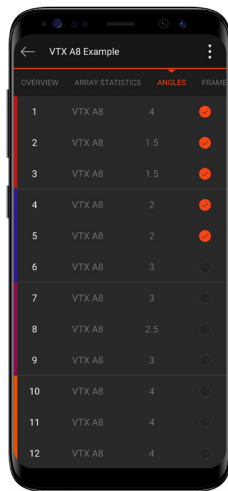

5.2 - ARRAY LINK™

JBL Array Link is a mobile companion app that works in conjunction with JBL's LAC software to assist with deploying JBL VTX Series systems. Array Link uses a QR code system to transfer all mechanical array information from the main LAC application to a mobile phone. All relevant rigging and mechanical options are presented in an easy-to-understand layout. The application is compatible with iOS® and Android™ and can be obtained from the respective app stores.

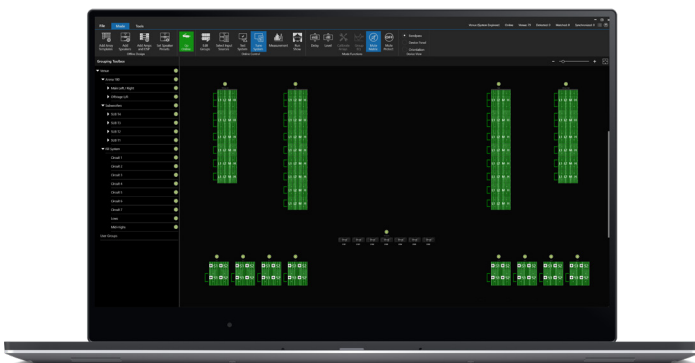

5.3 - PERFORMANCE MANAGER™

JBL® Performance Manager™ is a software application designed to configure and control networked audio systems. The workflow paradigm of the Performance Manager interface guides the system designer through the complete system design, configuration and control process. A dedicated show mode provides all the monitoring and control needed to have a complete picture of how the system is performing in real time.

www.jblpro.com/performancemanager

6 - OVERVIEW

The VTX B18 is JBL Professional's next-generation single 18" subwoofer, designed to complement VTX full-range sound reinforcement systems. The VTX B18 features JBL's new 2288H 18" woofer, engineered for improved linearity, increased sensitivity and extra-long excursion. The 2288H is based on JBL's Differential Drive, dual voice coil, dual-gap technology, which delivers better heat dissipation,



lower power compression and wider dynamic range than conventional single-coil designs. The B18 incorporates JBL's patented Slip Stream™ double-flared exponential low-frequency port design to improve airflow and reduce audible turbulence, even at maximum excursion. The B18 shares the industrial design of the JBL's VTX A-Series products and has the same width and suspension hardware as the VTX A8, allowing the two products to be used together in a variety of flown or ground-stacked configurations. The VTX B18 can be deployed in omni-directional or cardioid configurations, in arrays of up to 16 enclosures.

TRANSDUCER DESIGN

The VTX B18 features JBL's first new 18" high-performance woofer design in a decade, engineered from the ground up to deliver transparent, linear bass response down to 28 Hz. The 18" driver leverages JBL's patented fourth-generation Differential Drive technology to deliver maximum sensitivity and power handling in a light, compact design.

VTX A8 COMPATIBILITY

The B18 rigging system is compatible with the VTX A8 rigging system, allowing B18 subwoofers to be suspended above an A8 array. The VTX B18 rigging system allows for omnidirectional or cardioid configurations in small and large-scale flown or groundstacked arrays. All VTX A8 suspension accessories are compatible and arrays of up to 16 enclosures can be created.

CONTROLLABLE COVERAGE

The VTX B18 can be used in omni-directional or cardioid configurations simply by selecting the appropriate speaker preset and cabinet orientation. Speaker connectors are available on both the front and back, streamlining cable management in either configuration. A switch on the rear input panel allows for selecting between channel 1 or 2 of the NL4 cable, minimizing cable requirements.

VTX BUILD QUALITY

The VTX B18 adopts the VTX A-Series' signature full-face grille design, which minimizes exposed components and protects the loudspeaker from extreme conditions.

7 - CONNECTIONS

The VTX B18 is equipped with four Neutrik NL4 SpeakON connectors, two at the rear for the cabinet and two at the front grill. All four NL4 connectors are wired in parallel and can be used interchangeably. The NL4 connectors at the front of the B18 are typically used when the B18s are setup in a cardioid configuration and when some of the enclosures are pointed backwards. All NL4 connectors are installed upside down so that the NL4 locking pin position can be seen from under the array.

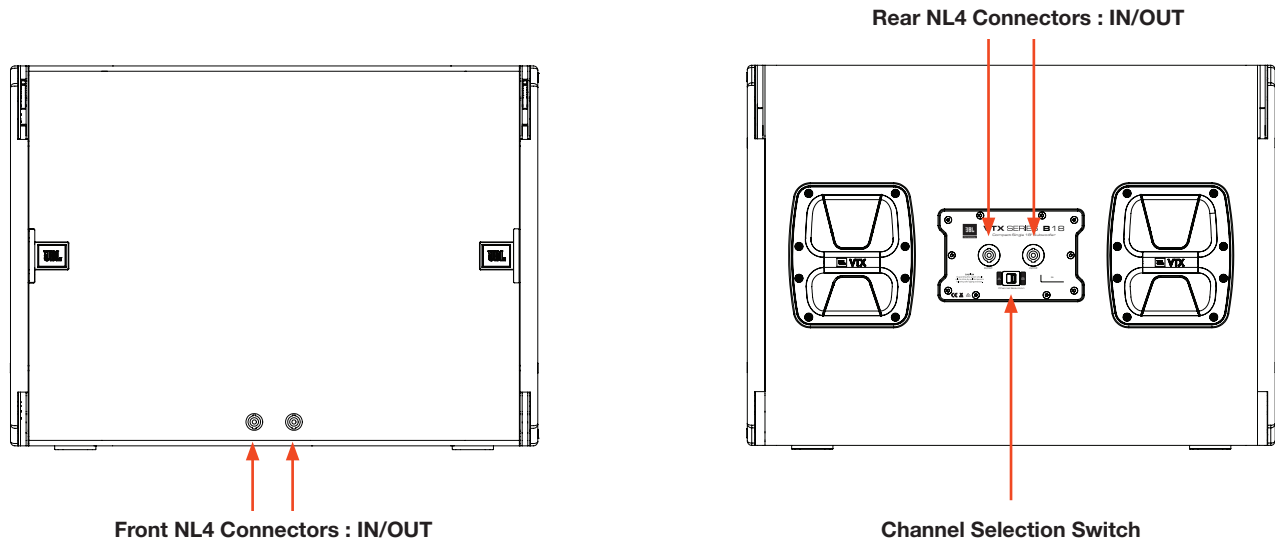

A channel selection switch is available at the rear of the B18 which allows for selecting between Pin-1 and Pin-2 of the NL4 connector/cable. The switch is wired after the four NL4 connectors and affects all connections equally.

7.1 - INTERNAL WIRING

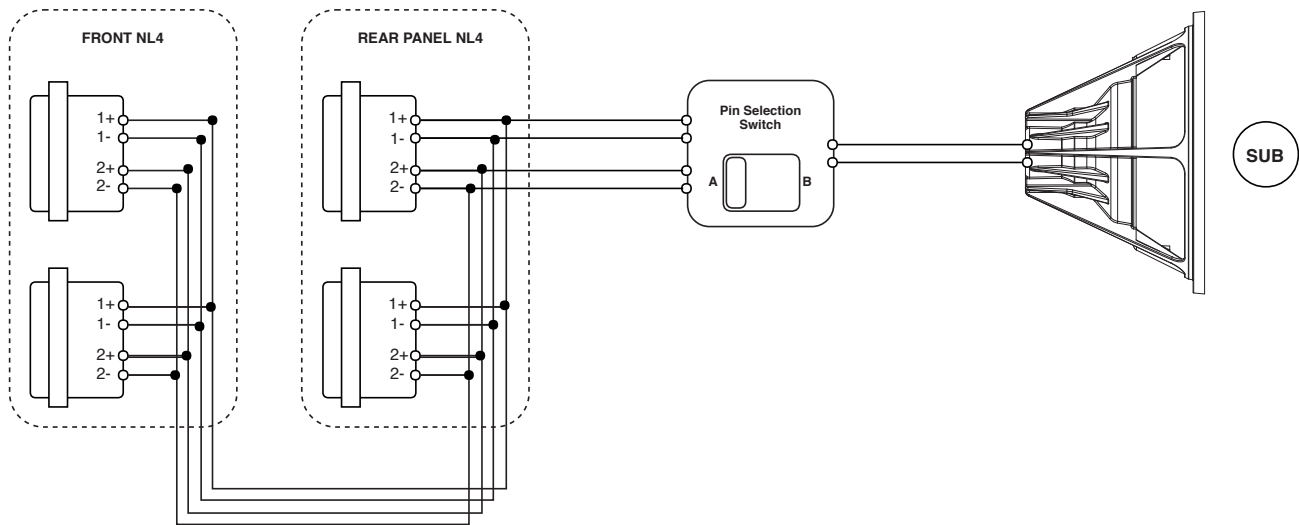

CAUTION: Always use high-quality insulated speaker cables made by reputable manufacturers. Keep cable length as short as possible with sufficient gauge for the application.

8 - TRANSPORTATION OPTIONS

There are two transportation options for the B18. One is the vertical transportation cart (VTX B18 VT) which allows for vertically transporting up to four B18 subwoofers. When stacked in blocks of 2, 3 or 4, B18 cabinets can be configured in either front-firing or cardioid mode (the CVR soft cover can cover stacks of 2 or 3 B18s). The VTX B18 VT CVR, a reinforced protective cover, is available to cover and protect the subwoofers during transportation. The other option is using the VTX B18 ACC accessory kit, which includes a front face dolly for a single B18 and a protective cover. The VT option is ideal for large scale touring situations where large format trucks are used and maximum deployment efficiency is needed.

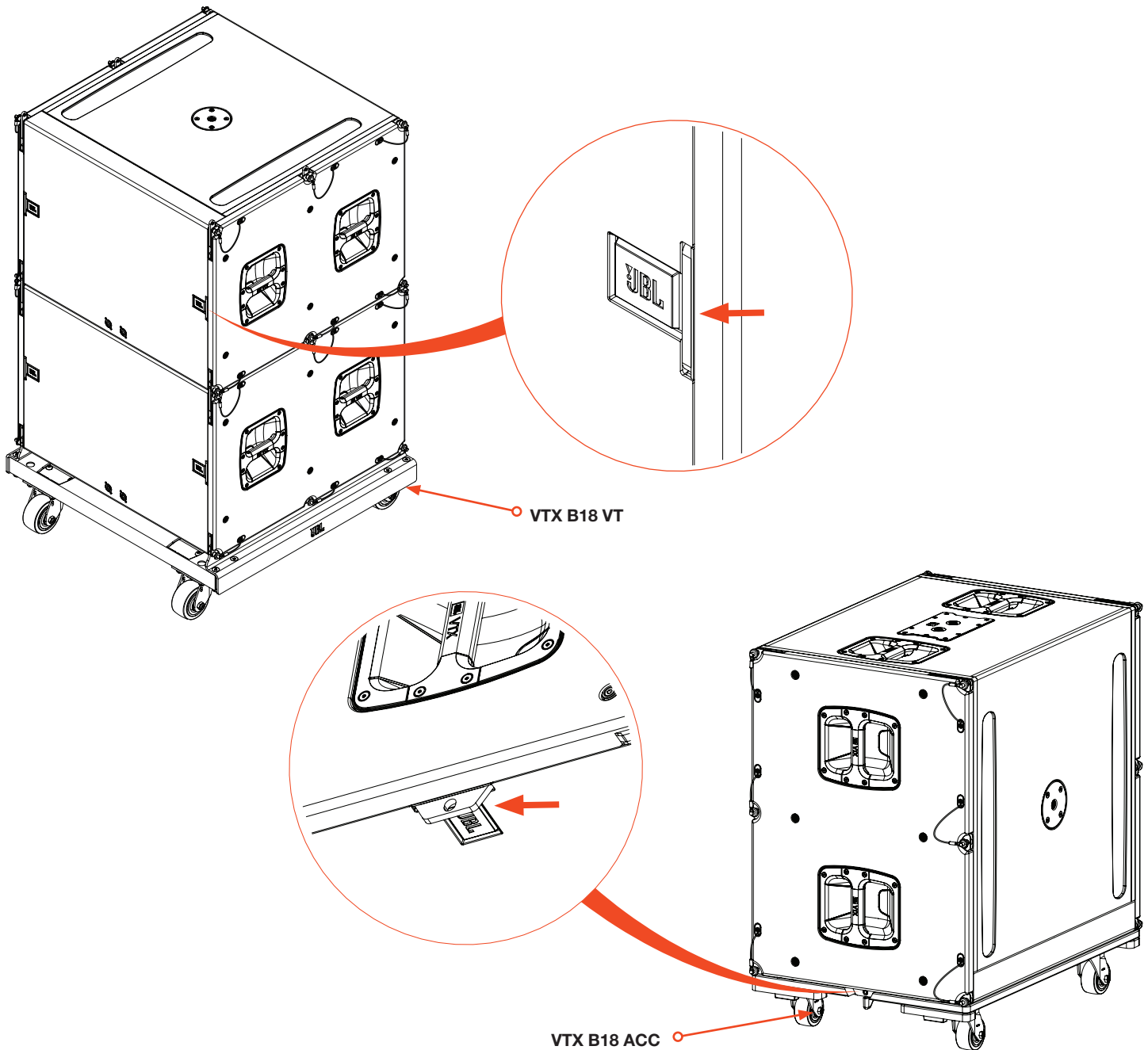

TIP: For additional information on how to use and deploy the ACC and Vertical Transporter refer to the VTX B18 Rigging manual that can be downloaded from the JBL Professional website.

8.1 - ROTATING THE DOLLY TABS - FOR USE WITH THE ACC DOLLY

There are two dolly tabs available at the front of the B18 that are used to secure the front face ACC dolly board to the B18. The tabs are retractable and ship from the factory oriented towards the inside of the B18. This orientation is ideal when the B18s are used with the vertical transport cart in which case the tabs are not needed. When the B18 is used with front face dolly boards the tabs are rotated so that the dolly board can be attached to the subwoofer.

STEPS:

- 1 Remove the 4 x M6 HEX screws holding the grill onto the B18
- 2 Carefully disconnect the Molex™ connector which is used to connect the 2 front NL4 connectors to the B18

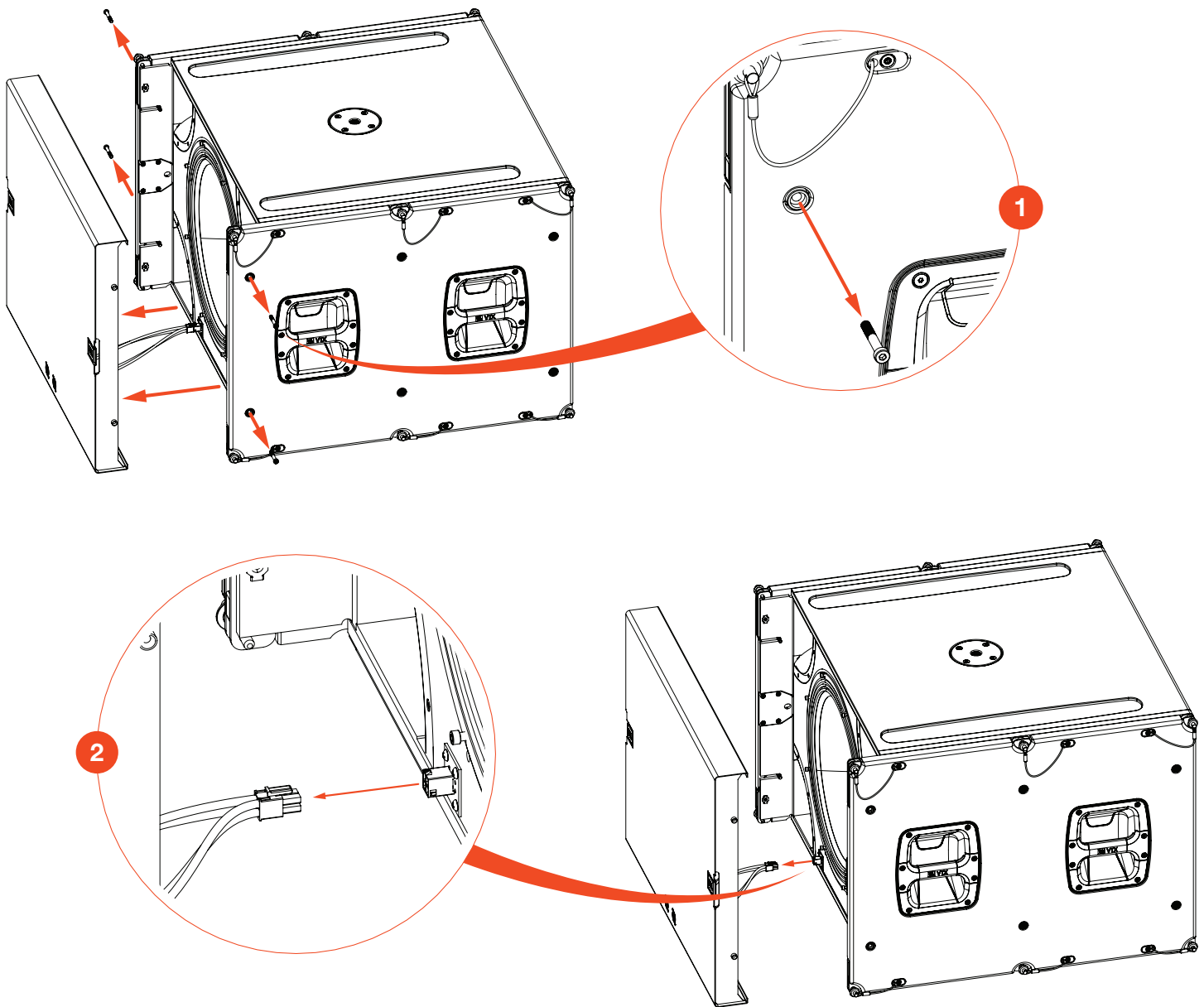

TOOLS REQUIRED: A 4mm HEX key is required to remove the four M6 screws holding the grill on the B18. A Phillips #2 screwdriver is required for removing the four Phillips screws holding the bracket.

STEPS:

- 3 Remove the 4 x Phillips screws holding each bracket, reverse the orientation of the brackets and reinstall the Phillips screws
- 4 Reconnect the Molex™ connector and secure the grill

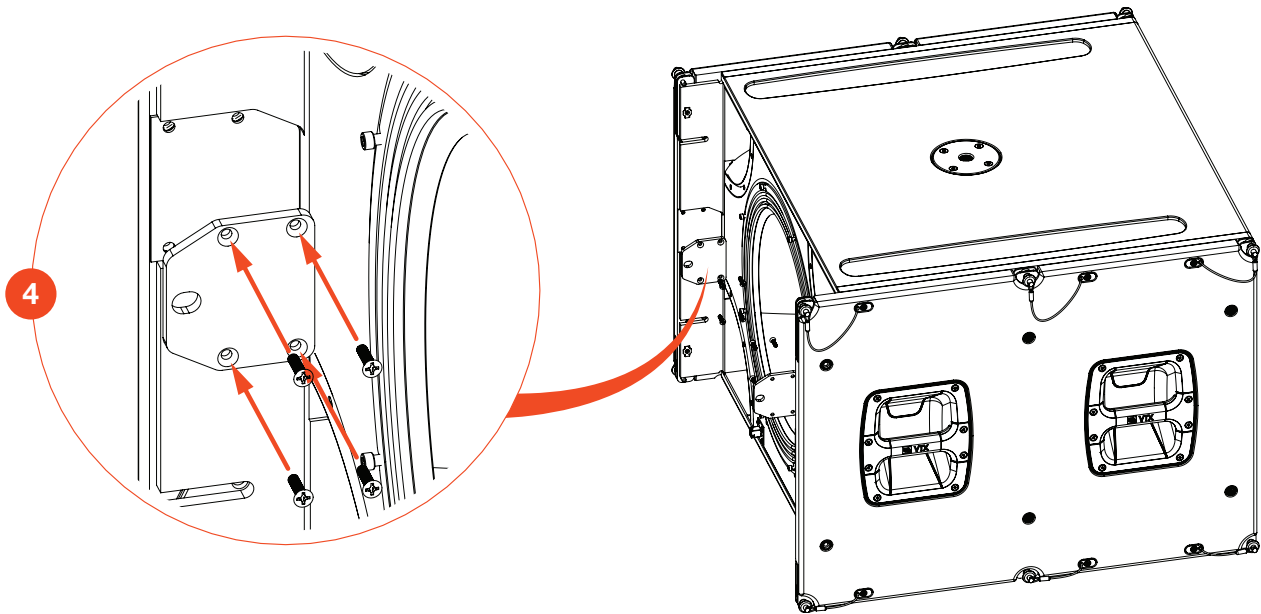
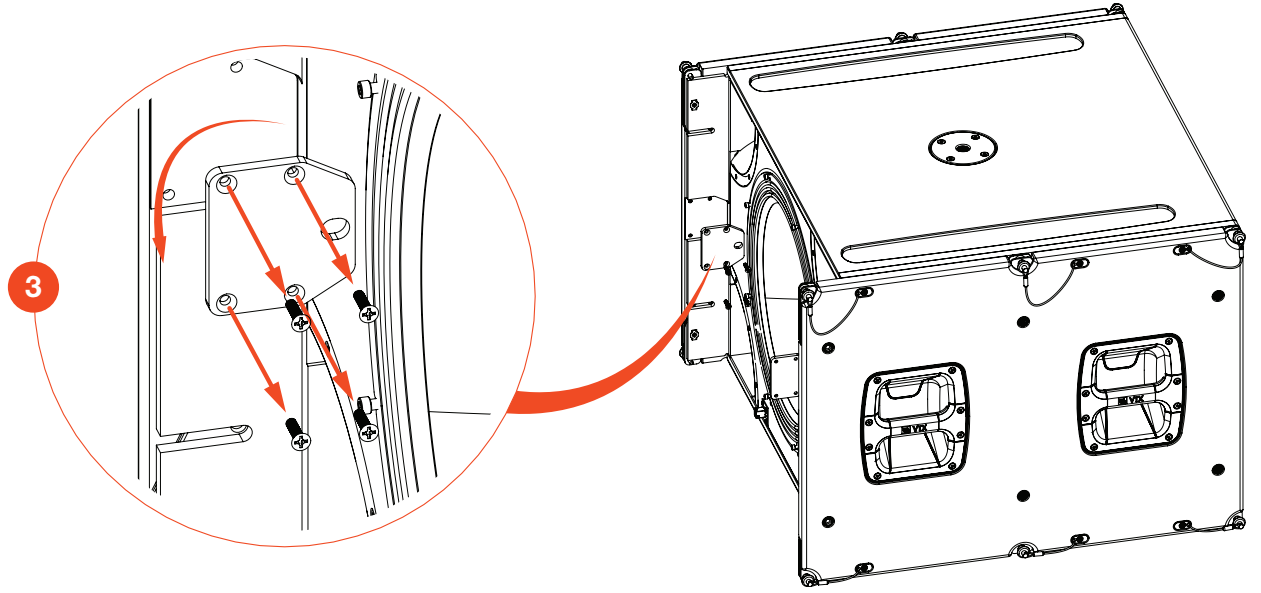

TOOLS REQUIRED: A 4mm HEX key is required to remove the four M6 screws holding the grill on the B18. A Phillips #2 screwdriver is required for removing the four Phillips screws holding the bracket.

9 - VTX B18 PRESET LIBRARY

The VTX B18 preset library includes 60 and 80Hz operating modes along with cardioid presets for rear facing subwoofer enclosures. VTX presets are exclusively developed for Crown I-Tech HD amplifiers and come bundled with JBL HiQnet® Performance Manager™ control software. Audio Architect presets are also available and can be downloaded from the JBL Pro website. See below for a detailed description of the B18 operating modes and processing options, and refer to the Preset Library setup sheets for preset descriptions, memory locations and output channel assignments.

9.1 - VTX B18 PRESET MODES AND OPTIONS

VTX B18 60: The 60Hz preset mode extends the upper frequency response of the B18 to 60Hz. The B18 60 preset is normally used when VTX full-range cabinets (like the A8 or A12) are used in full-range mode and minimal overlap between the subwoofers and full-range cabinets is desirable.

VTX B18 60 REAR: The 60Hz rear preset was designed to work in conjunction with the standard B18 60 preset and used to drive rear-facing B18 cabinets in cardioid configurations.

VTX B18 80: The 80Hz preset mode extends the upper frequency response of the B18 to 80Hz. The 80Hz preset is normally used when VTX full-range cabinets (like the VTX A8 or A12) are set to 80Hz, or when additional overlap between the full-range and subwoofer cabinets is desirable.

VTX B18 80 REAR: The 80Hz rear preset was designed to be work in conjunction with the stand B18 80 preset and used for rear-facing B18 cabinets in cardioid configurations.

9.2 - TIME ALIGNMENT

The VTX B18 presets provide proper system summation with companion VTX full-range cabinets (all models) under physically coupled configurations (stacked or suspended) and when used with corresponding 60 or 80Hz presets. This pre-alignment is done at the factory, allowing any VTX subwoofer to be used with any VTX loudspeaker without needing specific subwoofer presets for each system and configuration. Additional time alignment delay should be added, as necessary, to account for physical path length differences between suspended full-range arrays and ground-stacked VTX subwoofers.

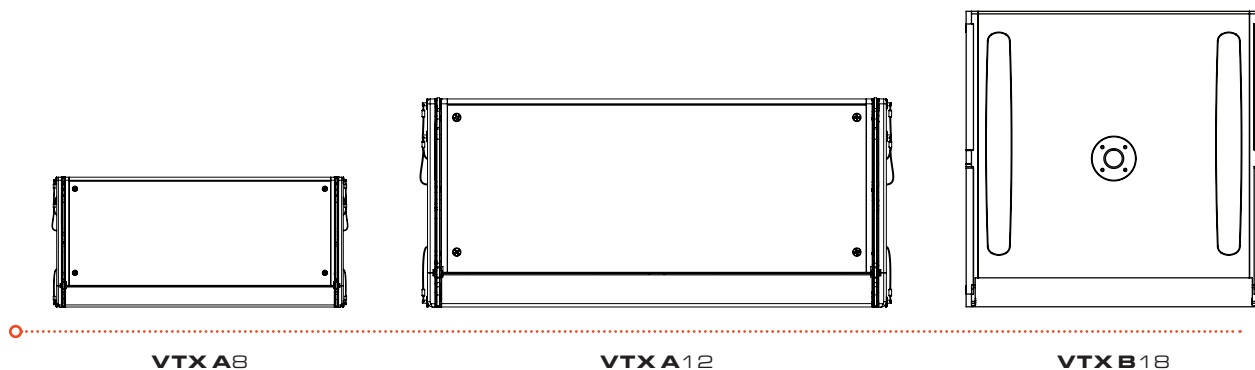

10 - SYSTEM AMPLIFICATION & WIRING

Like all other VTX systems, the VTX B18 subwoofer is powered exclusively by Crown I-Tech HD amplifiers, providing optimum performance and consistency across the world. All B18 processing is performed using the I-Tech HD's internal processing, so no other external DSP is required. The Crown amplifiers include a user-adjustable input section for room correction equalization, array size compensation and circuit adjustments.

Standard JBL presets are available for both the Crown I-Tech 4x3500HD and Crown I-Tech 12000HD. The most up-to-date presets are available for download from the www.jblpro.com website and are always bundled in the latest version of JBL's Performance Manager™ control software.

10.1 - B18 USING CROWN I-TECH 12000HD

When using Crown Audio I-Tech 12000HD amplifiers, up to four VTX B18 (2 x per channel) subwoofers can be powered per amplifier. Based on the B18 component resource requirements, this allows for optimum power-to-transducer ratio without compromising the maximum SPL capabilities of the system. The example below illustrates how to connect 4 x VTX B18 cabinets to a 2-channel I-Tech HD amplifier using standard 4-conductor NL4 cables. One NL4 cable is used to connect the amplifier to the first B18 cabinet and then standard 4-conductor NL4 jumpers are used to connect all the cabinets together. The channel selection switch at the back of each B18 is used to assign each cabinet to the appropriate amplifier channel. Two B18s are set to A (channel 1, Pin 1) and two B18s are set to B (channel 2, Pin 2).

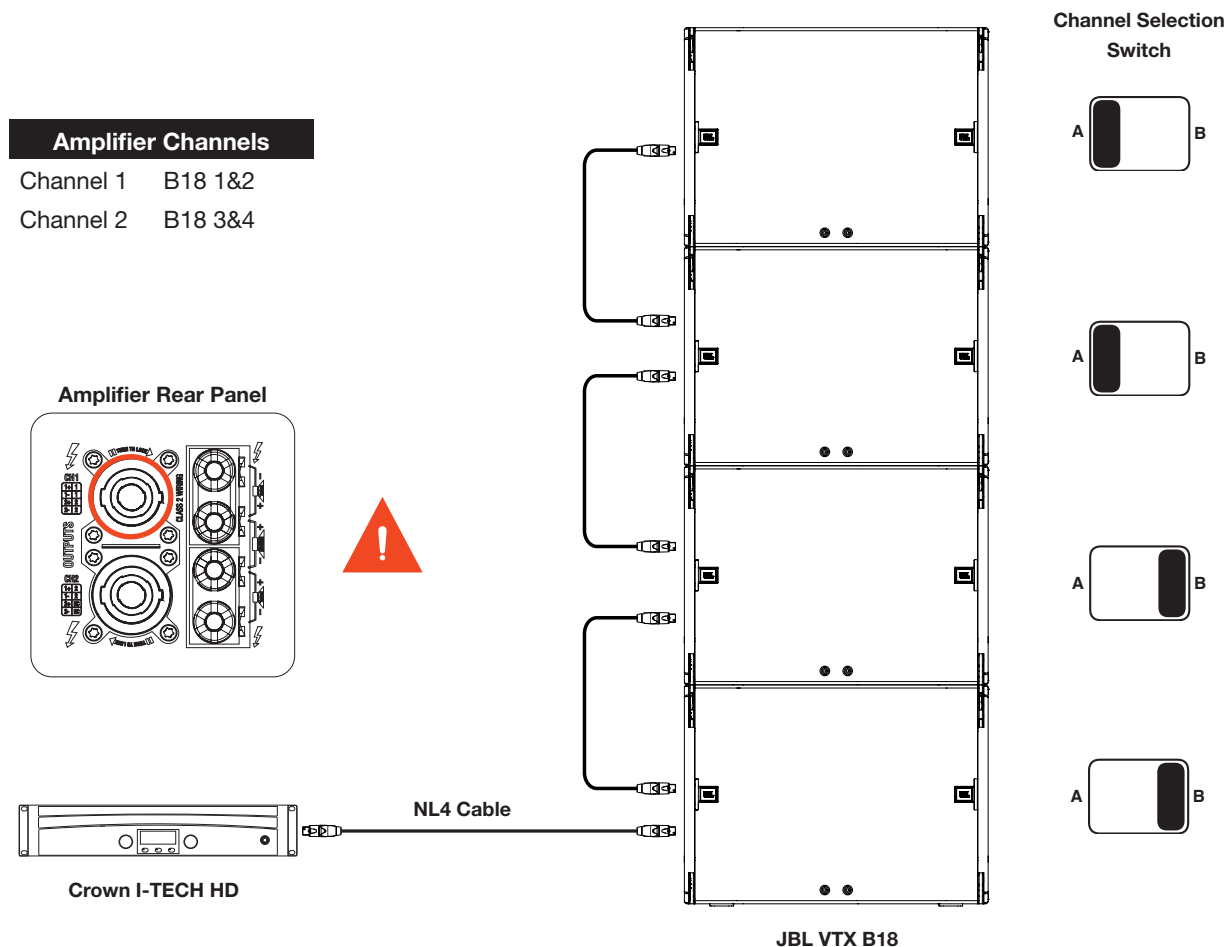

CAUTION: In this configuration, only the Channel-1 NL4 connector can be used on the I-Tech 12000HD amplifier. The Channel-1 NL4 connector is wired to both Channel-1 and Channel-2 were Channel-2 includes only Channel-2.

10.2 - B18 USING CROWN I-TECH 12000HD (CARDIOID)

Cardioid configurations can be created using Crown Audio I-Tech 12000HD amplifiers. In this case, any one of the amplifier channels can be set for cardioid using JBL Performance Manager software application. Up to two forward or two rear facing B18s can be used per amplifier channel. When 4-conductor NL4 cables are used, the B18 channel selection switch can be used to select which cabinet is driven by the cardioid channel. In the example below a 2:1 cardioid block of B18s is shown and powered by a single NL4 cable. In this configuration, the front grille NL4 connectors are used for wiring the rear facing B18 subwoofers.

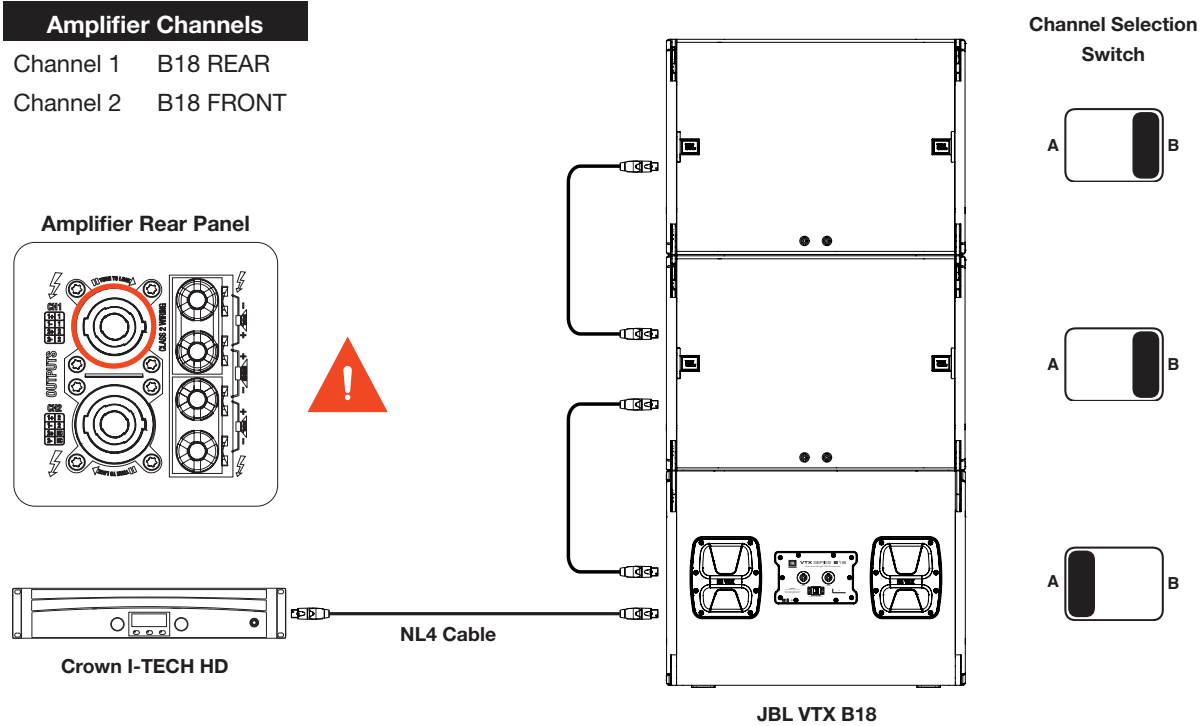

CAUTION: In this configuration, only the Channel-1 NL4 connector can be used on the I-Tech 12000HD amplifier. The Channel-1 NL4 connector is wired to both Channel-1 and Channel-2 were Channel-2 includes only Channel-2.



TIP: Other channel assignments can be implemented when using the 2-channel Crown Audio I-Tech HD amplifiers. Use JBL's HiQNet® Performance Manager™ control software to assign speaker presets.

10.3 - B18 USING I-TECH 4X3500HD

When using Crown Audio I-Tech 4x3500HD amplifiers, up to four VTX B18 (1 x per circuit) subwoofers can be powered per amplifier. Based on the B18 component resource requirements, this allows for optimum power-to-transducer ratio without compromising the maximum SPL capabilities of the system. The example below illustrates how to connect 4 x VTX B18 cabinets to a 4-channel I-Tech HD amplifier using standard 4-conductor NL4 cables. The channel selection switch at the back of each B18 is used to assign each cabinet to the appropriate amplifier channel.

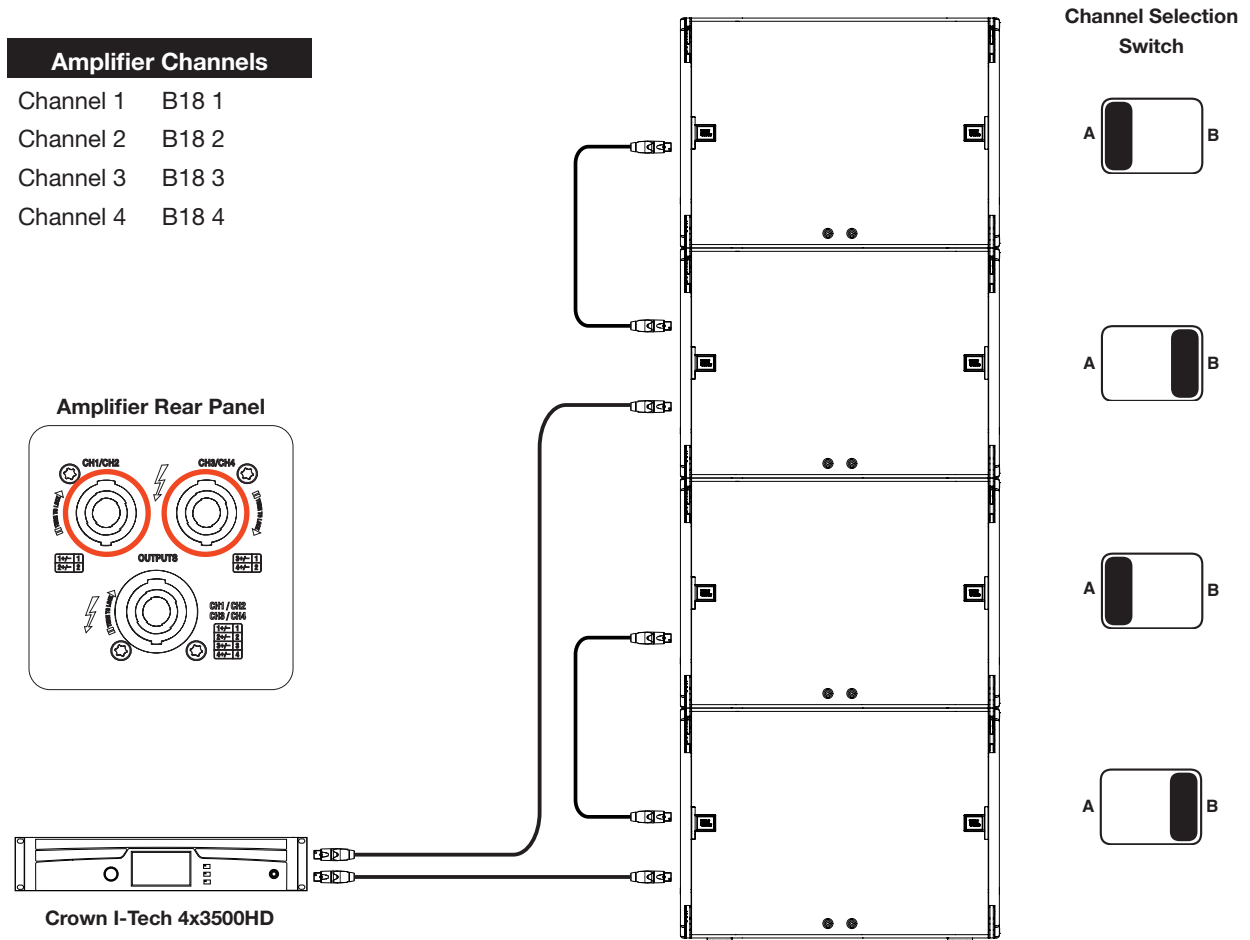

CAUTION: Make sure the total number of VTX B18 enclosures per circuit / amplifier does not exceed the maximum number recommended.

10.4 - B18 USING I-TECH 4X3500HD (CARDIOID)

Cardioid configurations can be created using Crown Audio I-Tech 4x3500HD amplifiers. In this case, anyone of the amplifier channels can be set for cardioid using JBL Performance Manager™ software application. Each amplifier channel is driving a single B18 enclosure and the channel selection switch at the back of the B18s can be used to assign B18 cabinets to the cardioid channels. In this configuration, the front grill NL4 connectors are used for wiring the rear facing B18 subwoofers.

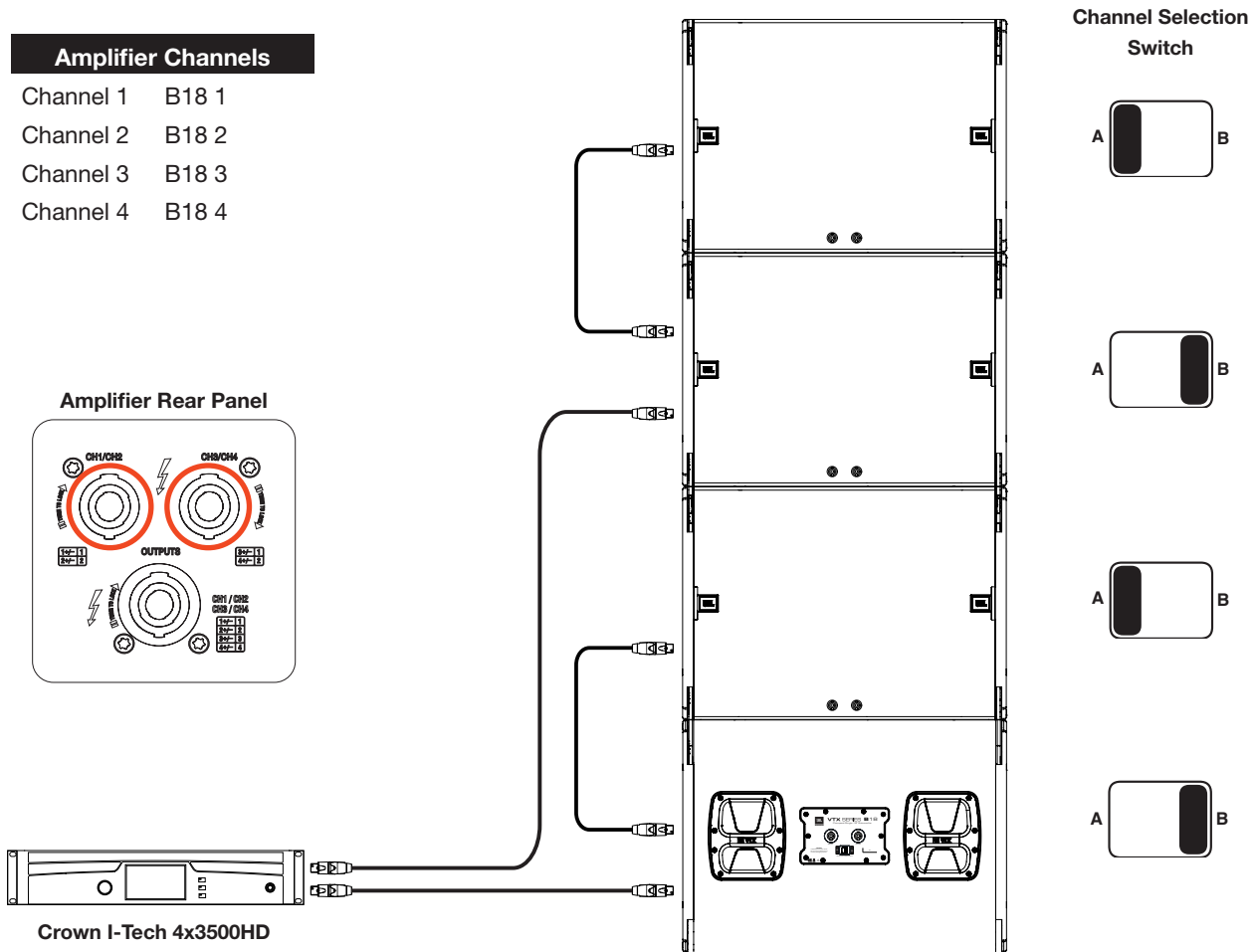

CAUTION: Make sure the total number of VTX B18 enclosures per circuit / amplifier does not exceed the maximum number recommended.

10.5 - CROWN AUDIO V-RACK

VTX series systems are compatible with the Crown Audio V-Rack 12000HD and Crown Audio V-Rack 4x3500HD touring racks. The number of supported cabinets per amplifier and wiring options remain the same as the Crown Audio I-Tech examples illustrated in this document. For more information on the Crown Audio V-Rack products, refer to the V-Rack User Manuals and documentation.

11 - CARDIOID CONFIGURATIONS

The directivity of a subwoofer is understood to be omni-directional, meaning energy is produced equally in all directions. In reality, most subwoofers do exhibit some front-to-back directivity (about 1 - 3dB depending on the frequency) but not enough to have any meaningful impact. In some cases, the omni-directional nature of subwoofers is desirable, but in some situations a more controlled (directional) coverage is more appropriate. The most common use case for directional subwoofers involves stage noise and specifically reducing excessive low-frequency energy from reaching the stage. Other reasons could include avoiding over-energizing a room with low-frequency energy or, for noise pollution purposes in outdoor concerts around residential areas.

The VTX B18 individually is an omni-directional subwoofer but a cardioid coverage can be achieved by physically reversing the orientation of some of the B18 cabinets and selecting the appropriate amplifier preset.

Example 1 : 3x VTX B18 in omni-directional mode (forward facing)

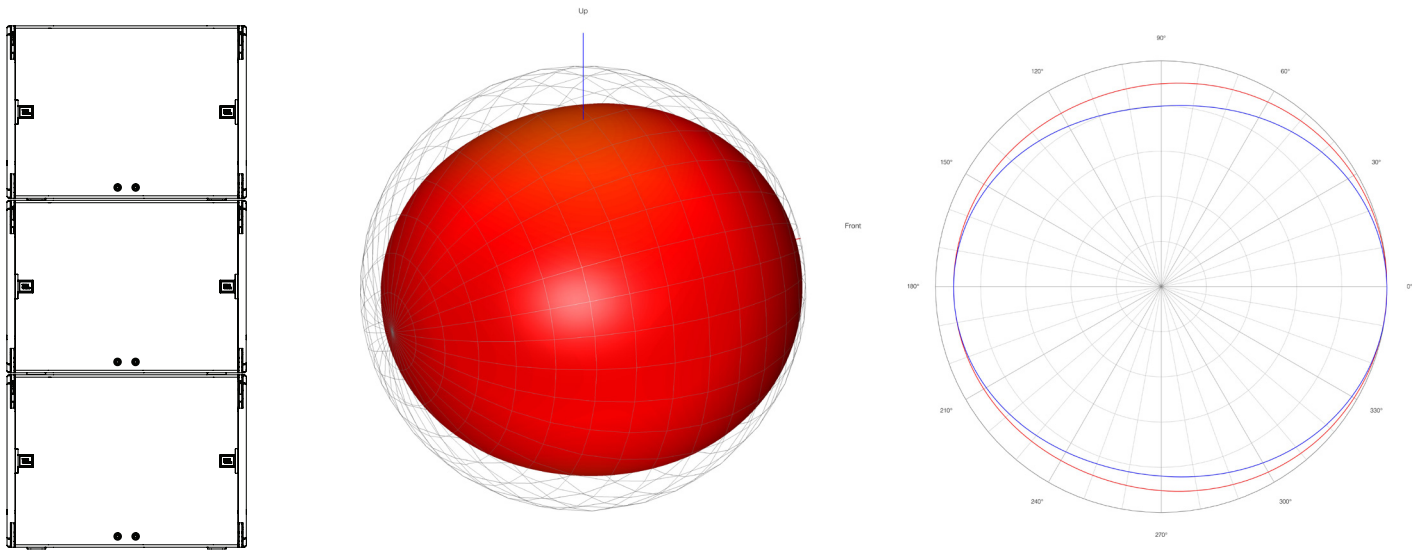

Example 2 : 3x VTX B18 in cardioid mode (front-rear-front)

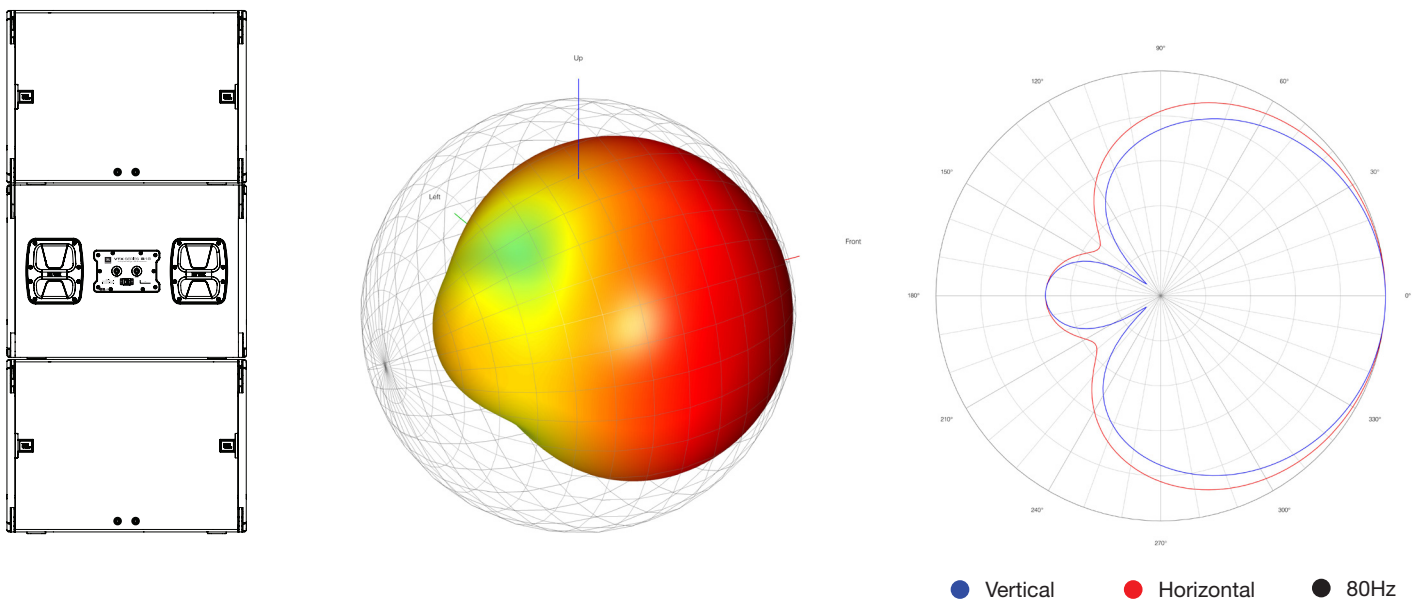

● Vertical ● Horizontal ● 80Hz

11.1 - GROUND STACKED CARDIOID CONFIGURATIONS

B18 subwoofers can be used in a number of ground stacked cardioid configurations depending on the available space and the number of cabinets. The main difference between configurations is the front to back subwoofer ratio. A ratio of 1:1 indicates that there is one rear facing subwoofer for every front facing subwoofer were a 3:1 ratio utilizes one rear facing B18 for every three front facing B18s. All configurations use the same cardioid amplifier preset (i.e. VTX B18 80 REAR) which means that the amount of rear rejection is controlled by the front-to-back ratio. Lower ratios produce higher rejection and higher ratios lower rejection.

Below are demonstrations of difference curves showing the front-to-back difference for the two most common B18 cardioid configurations (2:1 and 3:1). The 2:1 is ideal in terms of cancellation and produces 23dB of rejection at the lowest point (50Hz) were the 3:1 configuration produces 15dB of rejection at the lowest point. Depending on the amplification platform (2-channel vs 4-channel amplifiers) and available subwoofers, either configuration can be used with excellent results. In general, an 1:1 ratio should be avoided.

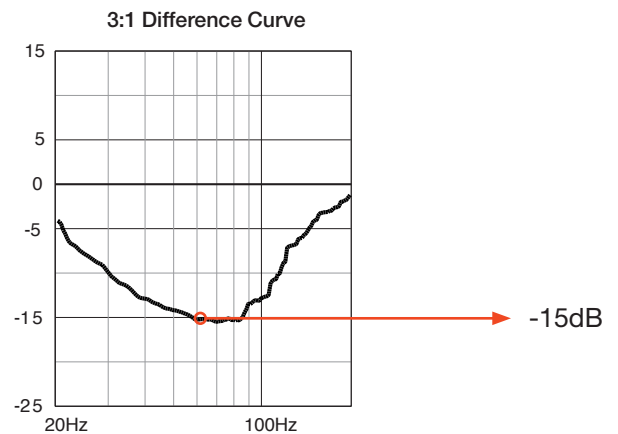
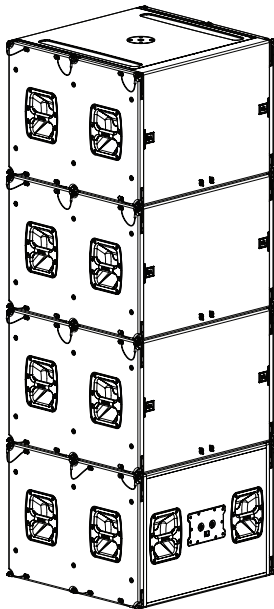
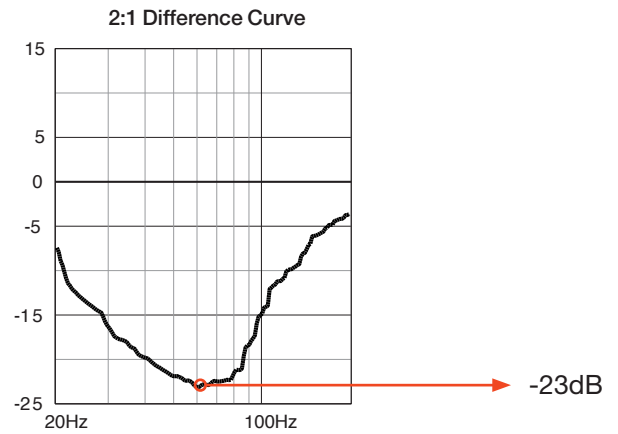
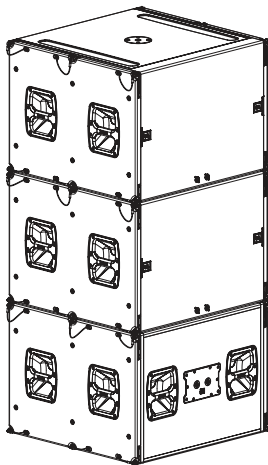

CAUTION: The level of the rear facing subwoofers should not be adjusted. The level was carefully selected to allow B18 cardioid arrays to reach MAX SPL without dynamically compromising low-frequency directivity.

11.2 - MINIMUM SPACE BETWEEN CARDIOID STACKS

When creating large subwoofer arrays using cardioid blocks of B18 subwoofers, some space should be allowed between the stacks to maximize rejection directly behind the array. As a minimum a distance of 1.5 meters (4.9') between stacks should be allowed.

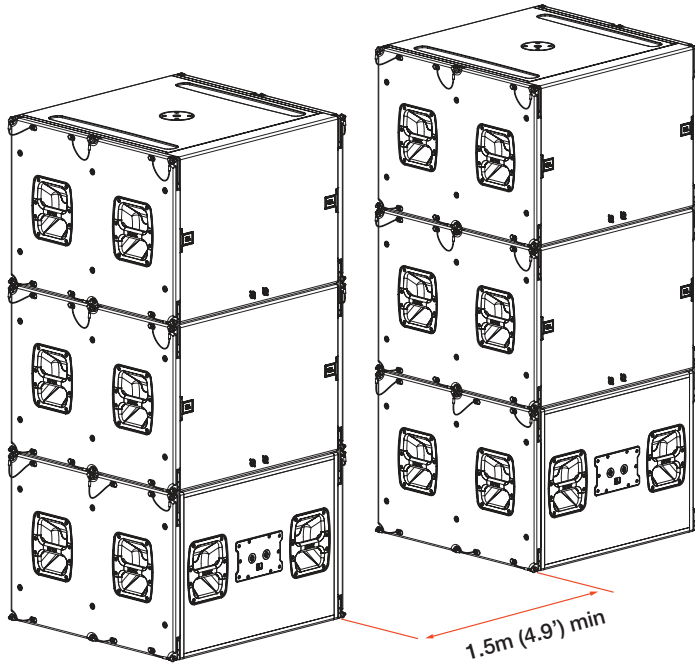

11.3 - MINIMUM SPACE FROM A WALL

When cardioid subwoofer stacks are placed in front of a solid structures (like a concrete wall or a solid stage), some space should be allowed behind the array for the cardioid effect to develop. A minimum space of 1.5 meters (4.9') should be allowed.

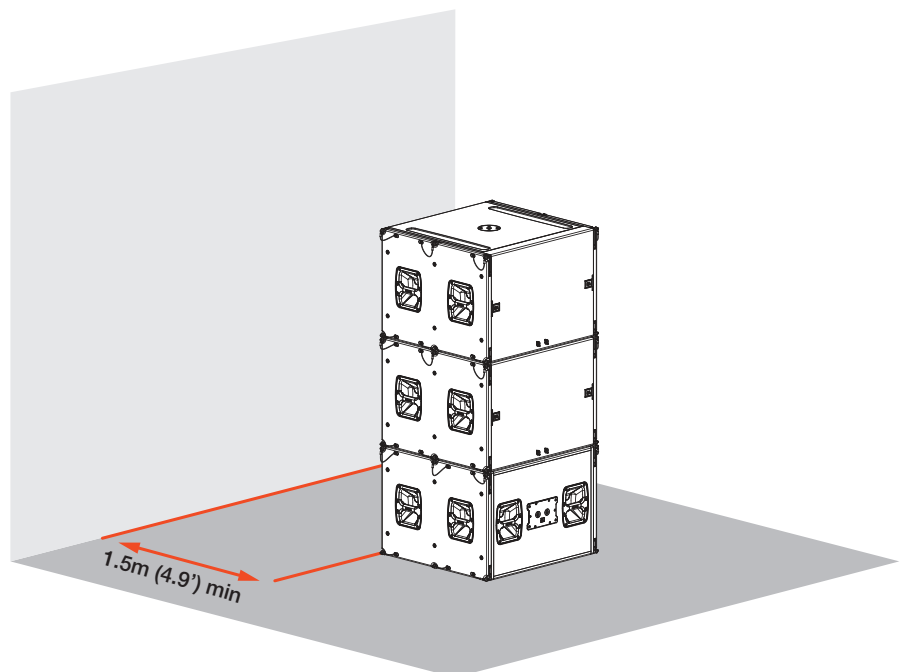

11.4 - CARDIOID VS OMNI - SPL DIFFERENCES

Its often questioned whether the rear facing subwoofers used for cancellation behind the array are positively contributing to the SPL produced at the front of the array. In other words, are cardioid stacks lossy, and if all available subwoofers were forward facing, would that array produce higher SPL?

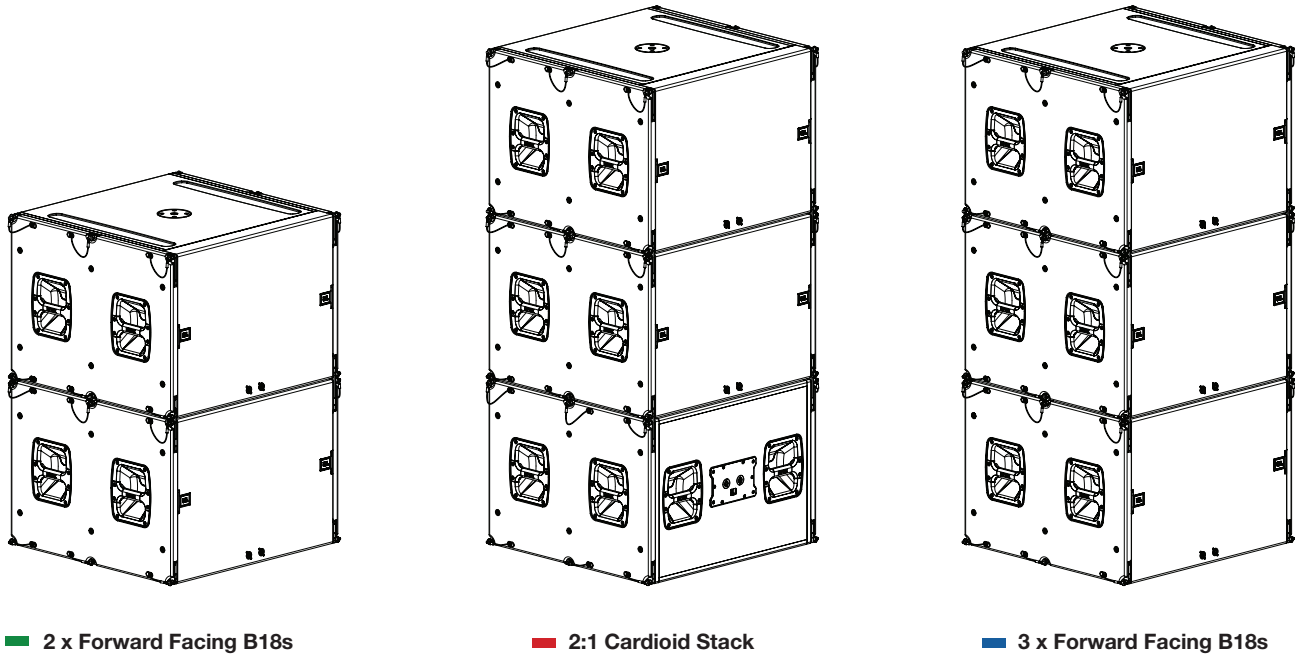

With the proper JBL preset, rear facing subwoofers, not only reject sound at the back of an array, but also positively contribute to the sound pressure at the front of the array. The contribution is not at the same rate as if all subwoofers were arranged facing forward but, they do contribute none the less. The curves below show the difference between the three examples shown in the illustration above. The 2:1 cardioid stack, produces marginally less SPL than the all forward stack of 3 (about 1dB) but significantly more SPL than the stack of 2. Therefore any subwoofers used for cancellation are not a loss and do contribute to the overall output of the array.

B18 SPL: Cardioid Vs all forward (measurements taken at 10m)

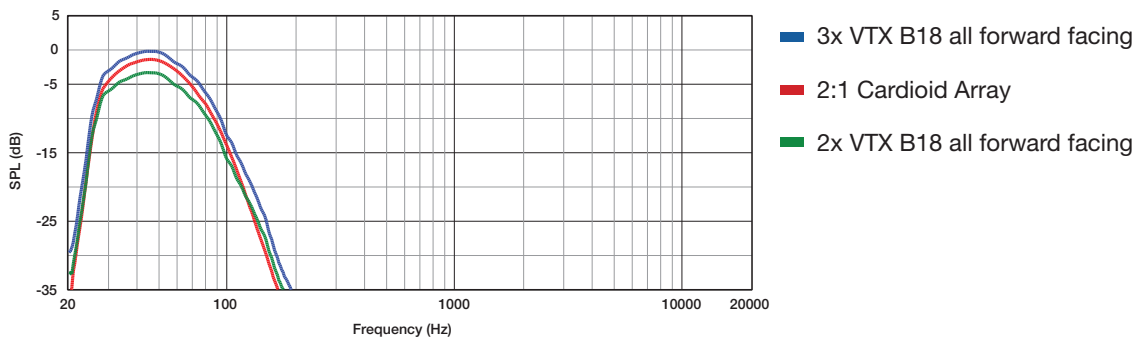

TIP: The point of maximum rejection of a cardioid stack is about 3 meters (9.8') behind the array.

12 - FLOWN CARDIOID CONFIGURATIONS

B18 subwoofers can be suspended in cardioid configurations using the VTX A8 suspension accessories like the VTX A8 Array Frame, the VTX A8 Mini Frame or the VTX A8 Suspension Bar. This chapter outlines good practices when using the B18 in flown cardioid configurations.

12.1 - ARRAY CONFIGURATIONS

When used in flown cardioid configurations, B18s should be used in blocks of 3 or 4, and when possible, in symmetric (top to bottom) arrangements. Symmetry ensures that the pattern produced by the array is axially symmetric with the physical array allowing for a more predictable coverage and aiming. None symmetric arrangements can be created, but should always be modeled in LAC-III first to ensure that the cancellation part of the array falls outside any of the audience areas.

The example below shows the difference between a F-R-F and a F-F-R array. As shown in the SPL maps below, when a rear-facing subwoofer is placed at the bottom of the array, the frontal coverage is tilted upwards and the rejection zone can fall within the audience areas which can have undesirable effects.

Example 1 : 3x VTX B18 symmetrically arranged (front-rear-front)

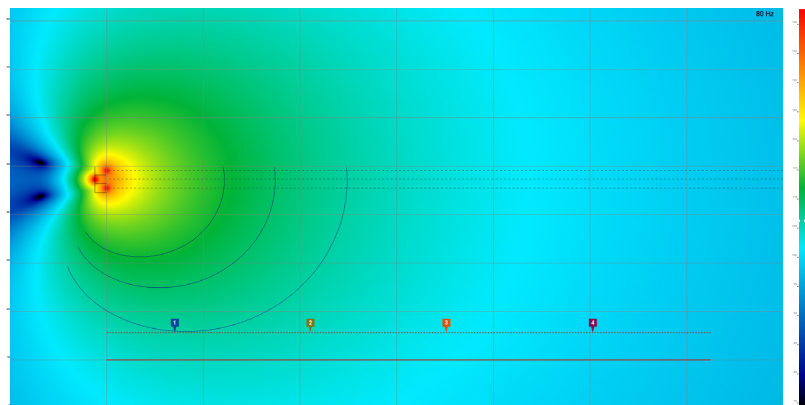
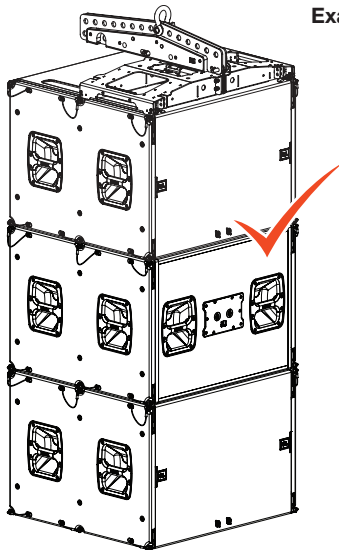

Example 2 : 3x VTX B18 in an asymmetric configuration (front-front-rear)

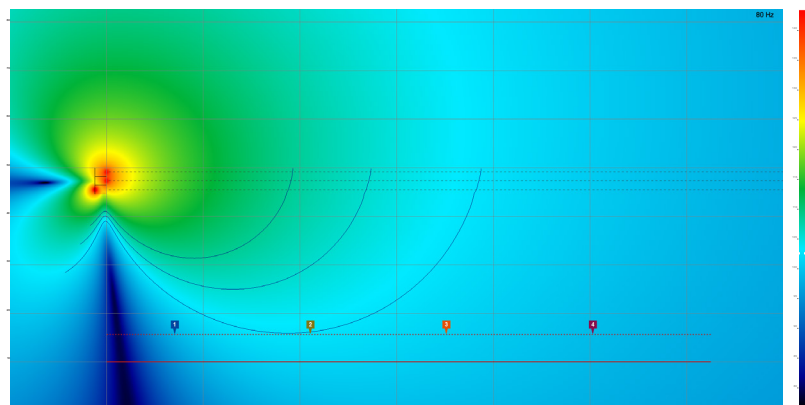
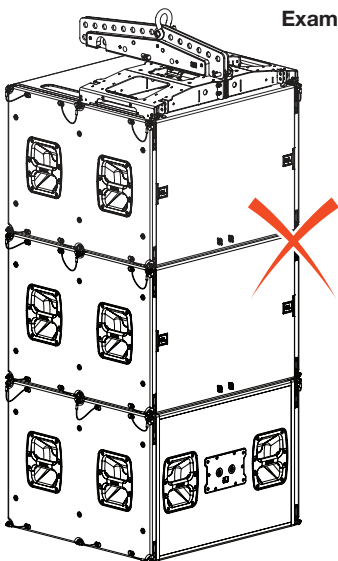

In some cases, none-symmetric arrays have to be used especially when the arrays are arranged in blocks of 4. In these cases, the produced coverage is always biased towards one direction, but strategic selection of placement can help shape the coverage to the specific need. As can be seen in the examples below, placing a rear-facing subwoofer at the bottom of an array is the least effective. Rear-facing subwoofers can be placed at the top of an array to keep energy off the ceiling.

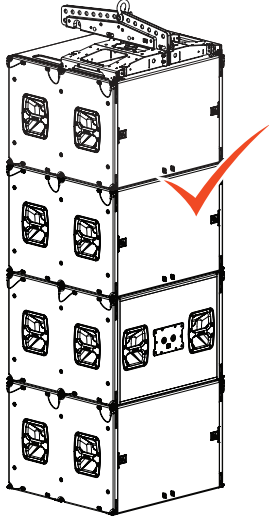

Example 3 : Block of 4x B18s (F-F-R-F) 80Hz

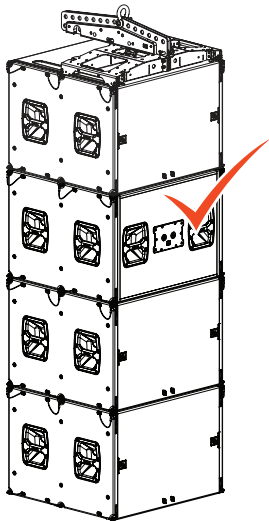
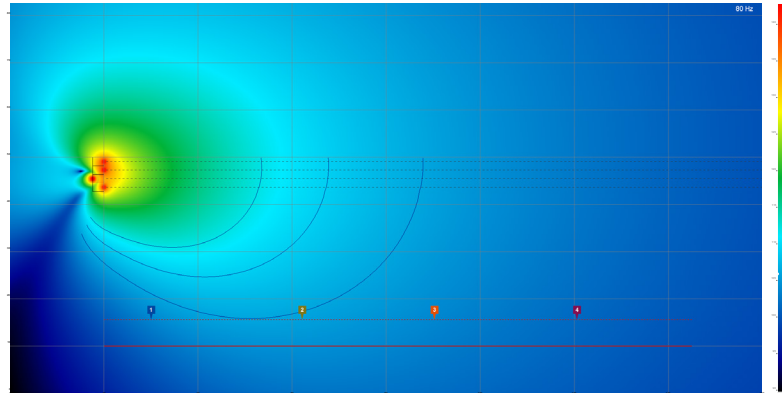

Example 4 : Block of 4x B18s (F-F-R-F) 80Hz

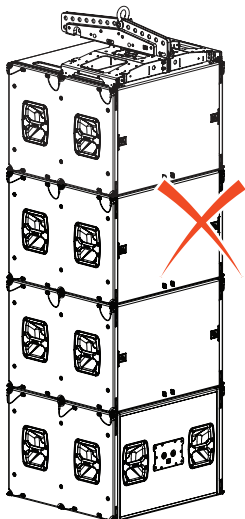
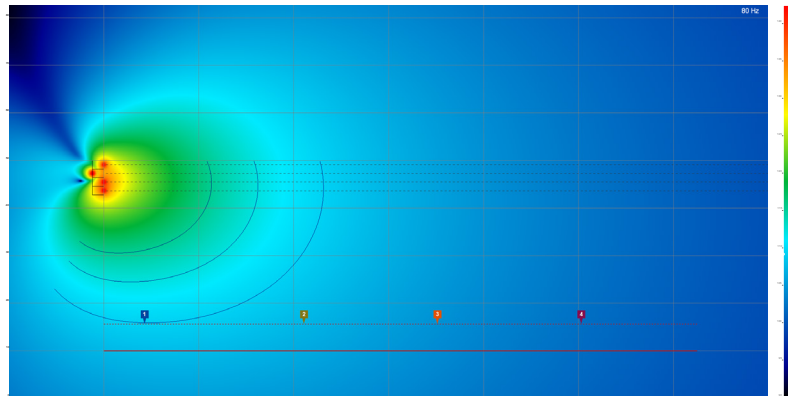

Example 5 : Block of 4 x B18s (F-F-F-R) 80Hz

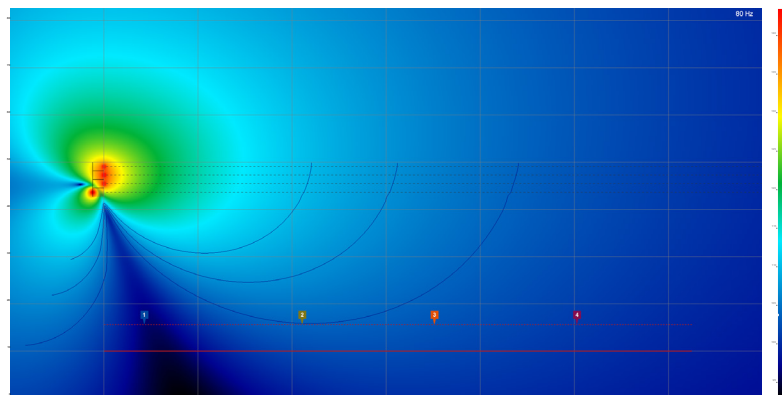

13 - CARDIOID PRESETS IN PERFORMANCE MANAGER

The JBL Performance Manager software application can be used to select the appropriate factory preset for any subwoofer configuration. Using Performance Manager, cardioid presets can be freely selected on a per amplifier channel basis to match the configuration and layout needed.

STEPS:

- 1 Navigate to the “Add Speakers” mode and drag-and-drop the necessary amount of B18s to the venue
- 2 Using the “Device View” selection control, switch the view to “Orientation”
- 3 Use “R” (REAR) and “F” (FRONT) switch buttons to reverse the orientation
- 4 Switch the “Device View” back to “Bandpass” view

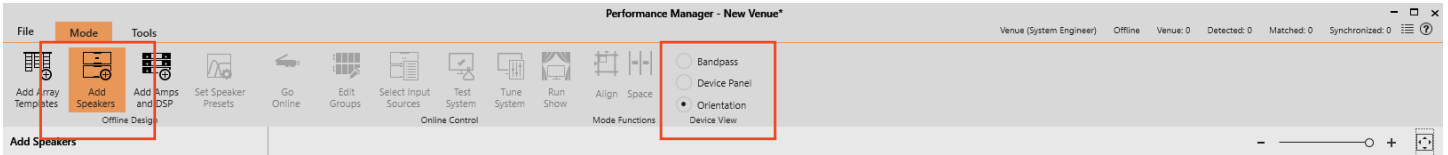

Once the orientation has been selected, Performance Manager assigns the appropriate corresponding factory preset to the amplifier channel(s) assignment with the selected B18. When B18s are grouped together on one amplifiers channel a common F/R switch is presented for the group. Cardioid arrays created in the JBL Line Array Calculator application can be imported into Performance Manager and all cardioid parameters are maintained.



TIP: The latest version of Performance Manager and Line Array Calculator can be downloaded at www.jblpro.com. Alternatively, the check for updated function can be used within the application.

13 - ELECTRONIC DELAY STEERING (EDS)

When constructing large horizontal subwoofer arrays, the overall size of an array can have a negative impact on the subwoofer coverage. The longer the array, the narrower the coverage. Electronic Delay Steering (EDS) is a technique used to alter the coverage angle of a given subwoofer array by applying a specific, pre-calculated delay value to each subwoofer enclosure. The goal of EDS is to electronically alter the shape of a subwoofer array and widen the coverage pattern by creating a virtual arc. The radius of the arc controls the radiating pattern of the array and each delay value is carefully calculated to align all subwoofers to the virtual arc. Hybrid cardioid EDS subwoofer arrays provide even horizontal coverage with 15–25 dB broadband SPL rejection behind the array.

13.1 - EDS EXAMPLE - NO DELAYS

The example below shows the unaltered coverage of a horizontally distributed array of B18 subwoofers. Each B18 cluster, consists of three B18 enclosures with the bottom B18 facing backwards to create a 2:1 cardioid configuration. The center-to-center spacing of the array was calculated at 2.5m (8.2') which makes the total length of the array 18.3m (60') long. Given the overall large size of the array, the array directivity increases, reducing the coverage to the center of the venue. The SPL Mapping below, was generated in LAC-3, and demonstrate the coverage of this array at 50Hz.

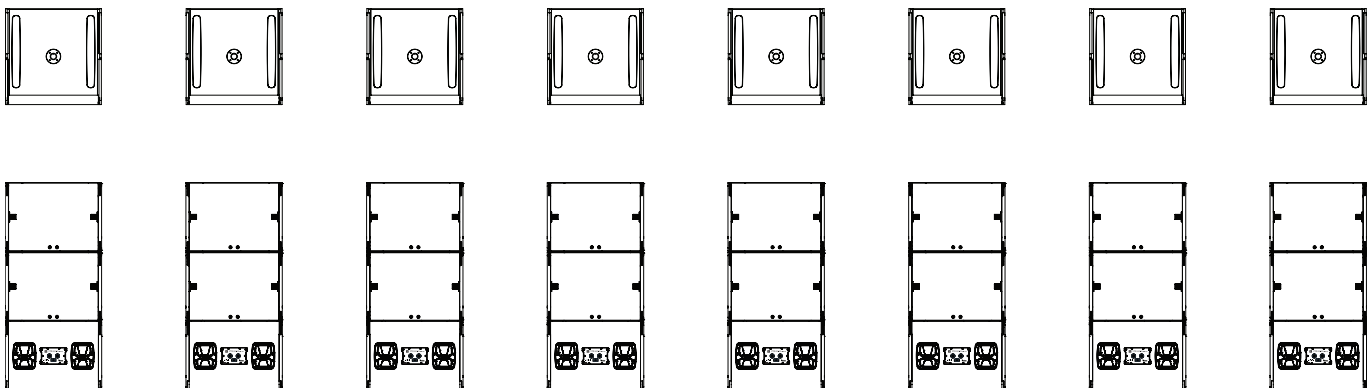
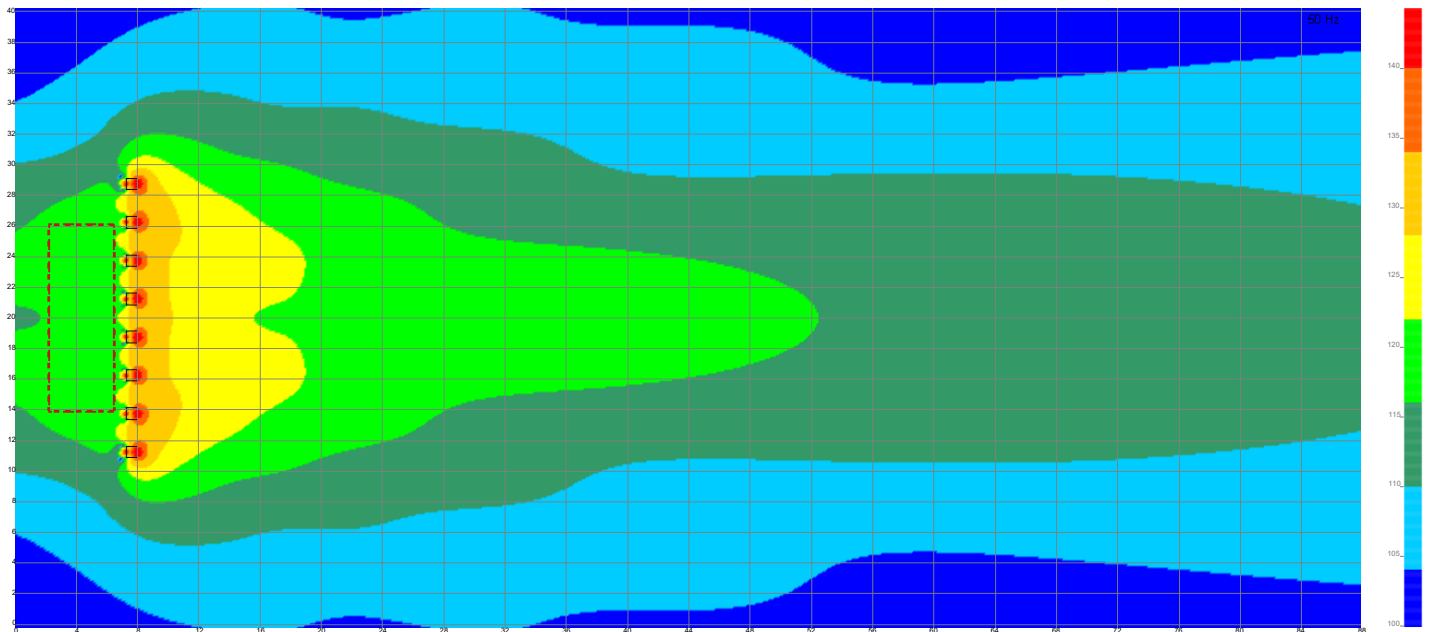

13.2 - EDS EXAMPLE - WITH DELAYS

To improve the coverage of this array (assuming a wider coverage is desirable), the delay calculation function of LAC-3 can be used to generate delay values for each B18 cluster and electronically alter the coverage of the array. The goal is to electronically curve the array for a predetermine angle, and “open” the coverage of the array. The SPL map below shows the coverage of the array using the delay values generated by LAC for an opening angle of 60°. As can be seen, the coverage is wider with more parts of the venue covered by the array.

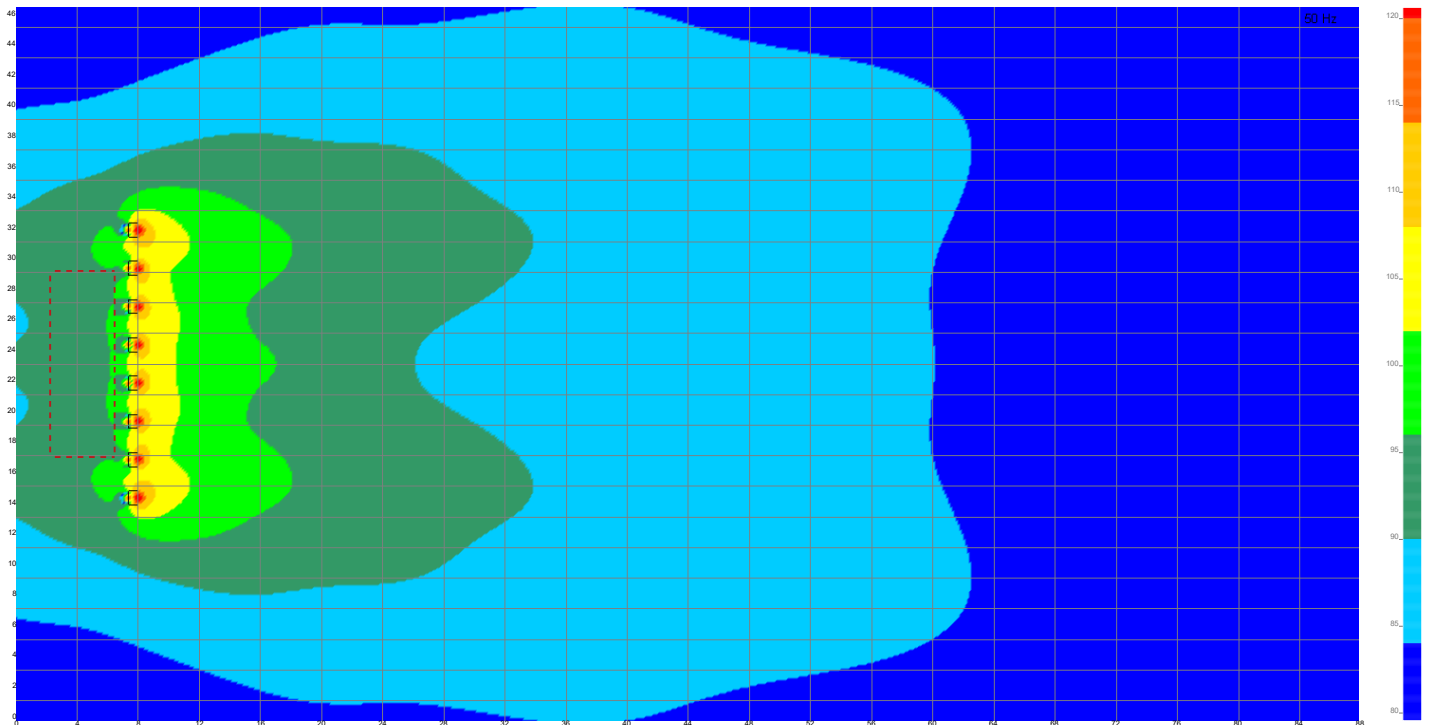

The illustration below shows the delay values generated by LAC (for a 60° angle) and the “virtually” arced array based on the delays. Delay values for different coverage angles and cluster spacing can be generated in LAC. Care should be taken not to over steer an array and significantly reduce energy on the on-axis positions.

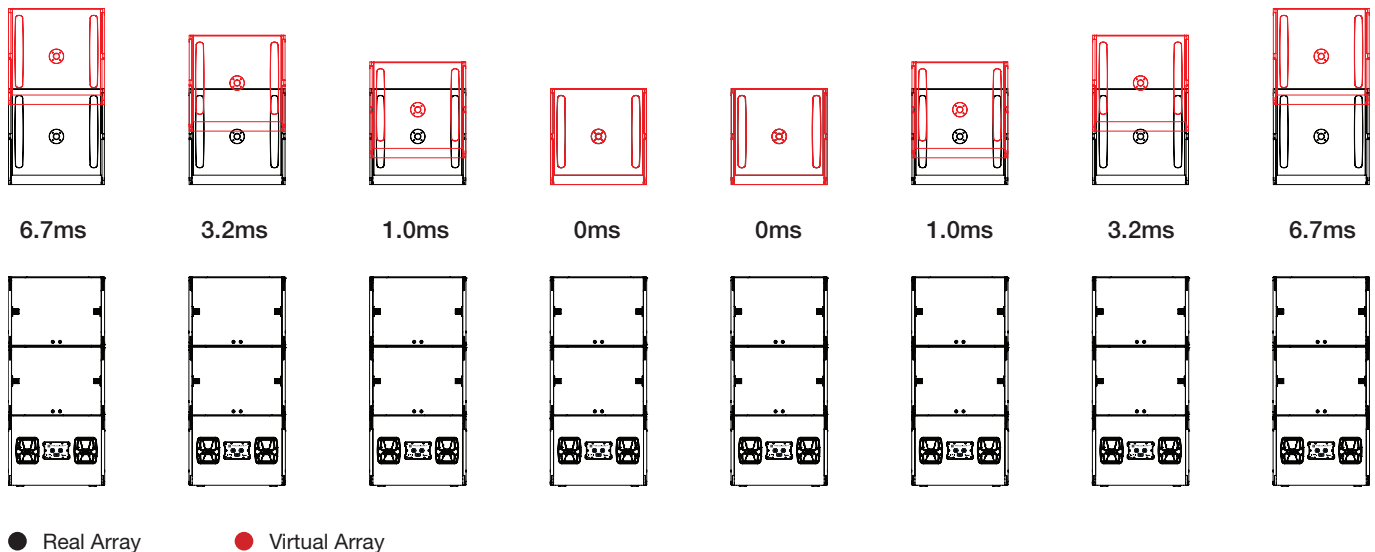

14 - TESTING VTX B18

Speakers need to be periodically checked and maintained in order to assure long-term performance and reliability, and the VTX B18 is no exception. While the system is designed for utmost reliability, it is important to confirm that the system is operating within specified tolerances to ensure optimal performance for years to come. Below are two methods that can be used to check and verify proper transducer performance in a VTX B18 system.

14.1 - USING A DMM (DIGITAL MULTI METER)

This method is best suited for when the speaker system is in the shop. A DCR (DC resistance) test with a multimeter can give a very accurate reading of how many transducers are properly wired together and within their standard operating tolerances. This test is appropriate for individual boxes and not groups.

With the B18 speaker unplugged from any amplifiers, set a DMM to the resistance (Ω) setting and place the probes across the Pin1+/- and Pin 2+/- leads. Record the values indicated on the DMM for each pair of leads and refer to the chart below to either confirm correct readings or investigate out-of-tolerance DCR readings.

	B18	
	DCR	Tolerance
B18 functioning	4.5 Ω	+/- 0.5 Ω
Driver shorted	0.2 Ω	-

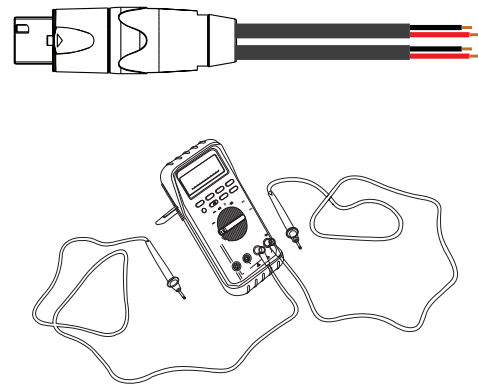
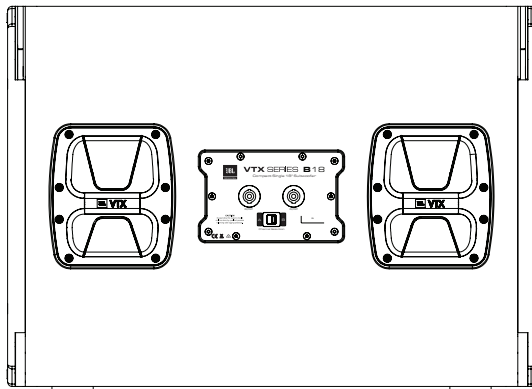

Notes:

- The DCR numbers listed above assume cold (room temperature) transducers. If taken right after use, and when the transducers are warm, the numbers will vary. For best results test the speakers cold.
- The DCR value of a transducer gives an accurate representation of its electrical state. Any mechanical defects are not characterized by this test. Refer to the VTX B18 service manual for instructions on how to perform a rub-and-buzz test using a sine wave generator.

14.2 - USING PERFORMANCE MANAGER

When in the field, the **Test System Mode** in Performance Manager can be used to test an A8/B18 system. This test method is quick and especially useful for determining whether all the speaker cables, including cabinet-to-cabinet NL jumpers, are properly functioning.

To perform the test, Performance Manager uses the I-Tech HD's built-in noise generator in conjunction with the amplifier's current draw and voltage sensing capabilities to generate a nominal load impedance reading for each amplifier output channel. Since broadband pink noise is used as the test stimulus, the returned value is considered to be an impedance value, and it will differ from the resistance values given earlier in this document (which are taken using DC Resistance).

STEPS:

- To start the test make sure Performance Manager is online and connected to the devices.
- Navigate to the Test System Mode and make sure all the speakers are muted
- Switch the Noise Generator to the ON position and change the level to a value between -30dB and -10dB. Values lower than -30dB may not be sufficient to trigger a reading.
- Unmute the speaker or a bandpass to start the measurement. The measured value is displayed on the speaker icons.

14.3 - PERFORMANCE MANAGER READINGS

Below are the expected impedance values for circuits of B18 cabinets. The measurements below were taken at room temperature with a cable length of 25m (82'). Acceptable tolerance is +/- 0.5 Ω .

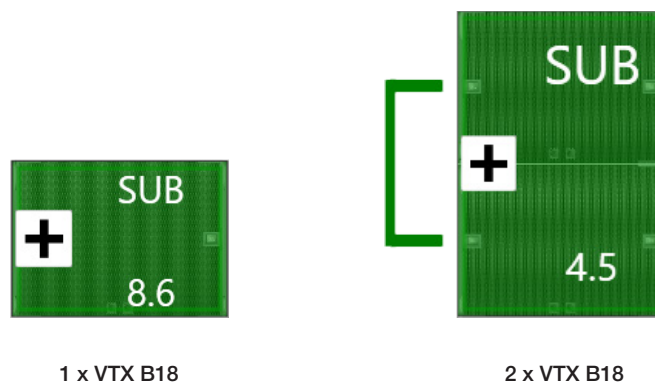

Due to variances in temperature, cable length, wire gauge and usage, the measurements recorded by Performance Manager are more susceptible to drifting based on conditions. However, condition variations like temperature are common across all similar circuits of a system. More important than the individual component values is consistency across similar circuits. For example, all 2 x Box circuits for an array should measure similarly. If one is off by several ohms then there is likely something wrong with that specific circuit.

15 - SPECIFICATIONS

15.1 - VTX B18

SYSTEM

Frequency Range (-10 dB): 28 Hz - 80 Hz (Preset: VTX B18 80)

Coverage Pattern Options¹: Omni-directional or Cardioid

System Input Power Rating²: 1300W Continuous (IEC/100 hour)

Maximum Peak Output³: 135dB (Preset: VTX B18 80)

System Amplification: Crown Audio I-Tech 12000HD
Crown Audio I-Tech 4x3500HD

Required Amplifier Channels: 1-channel

Number of Cabinets per Circuit

IT-12000HD: 2 x VTX B18

IT-4x3500HD: 1 x VTX B18

System Impedance⁴: 8 ohms

TRANSDUCERS

Low Frequency : 1 x JBL 2288H, 18in diameter, dual 4in diameter voice coil, neodymium Differential Drive

ENCLOSURE

Construction : 18mm and 15mm ,11-ply Baltic birch plywood, Black DuraFlex™ finish, integral recessed handles

IP Rating⁵ : IP55 (IEC 60529)

Suspension : Captive suspension plates, quick-release pins, spring-loaded mechanism

Grill : Powder-coated 14-gauge hex-perforated steel with acoustically transparent black cloth backing

Connectors

Type : Neutrik® SpeakON® NL-4 (2x at the rear and 2x at the front)

Pin Assignments : Selectable between Pins 1 ± and Pins 2 ±

Dimensions (H x W x D) : 551.68mm x 761.29mm x 736.6mm
21.72in x 29.97in x 29.0in

Net Weight : 68 kg (150 lbs)

Footnotes:

1: Based on speaker preset selection and cabinet orientation/configuration.

2: IEC Standard: IEC shaped noise with 6dB crest factor based on nominal impedance and a duration of 100 hours. Continuous is defined as 2x RMS.

3: Peak, unweighted SPL, measured under **half-space** conditions at 1 meter using broadband pink noise with a 12dB crest factor and specified preset.

4: Nominal impedance within the stated frequency range of the product. Minimum impedance is 5.6Ω is 150Hz.

5: Front face at 0 degree or greater down angle to allow the cabinet to drain water. Suspension components fully weather rated for indoor or covered outdoor conditions where humidity is nominally under 50% and not local to bodies of corrosive materials.

JBL continually engages in research related to product improvement. Some materials, production methods and design refinements are introduced into existing products without notice as a routine expression of that philosophy. For this reason, any current JBL product may differ in some respect from its published description, but will always equal or exceed the original design specifications unless otherwise stated.

16 - ACOUSTIC MEASUREMENTS

FREQUENCY RESPONSE

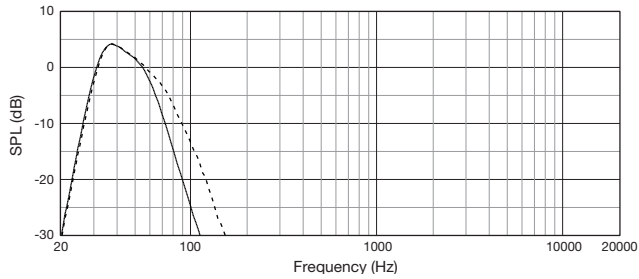

— VTX B18 60 - - - VTX B18 80

17 - DIMENSIONS

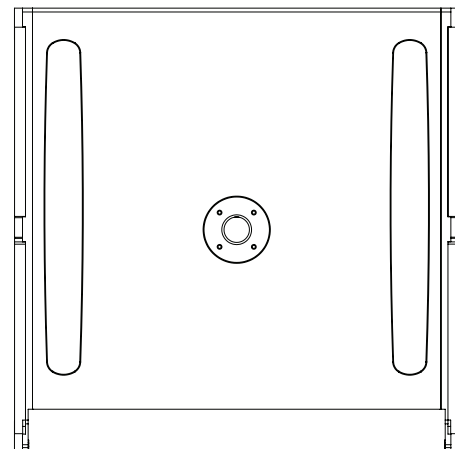
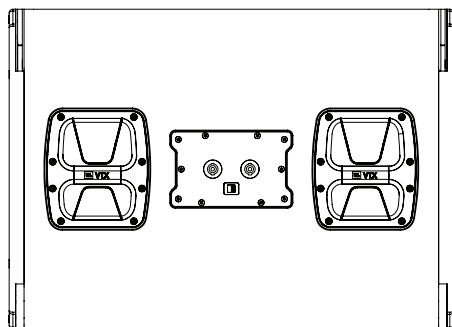
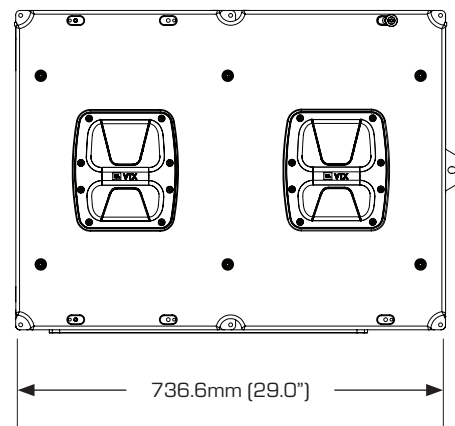
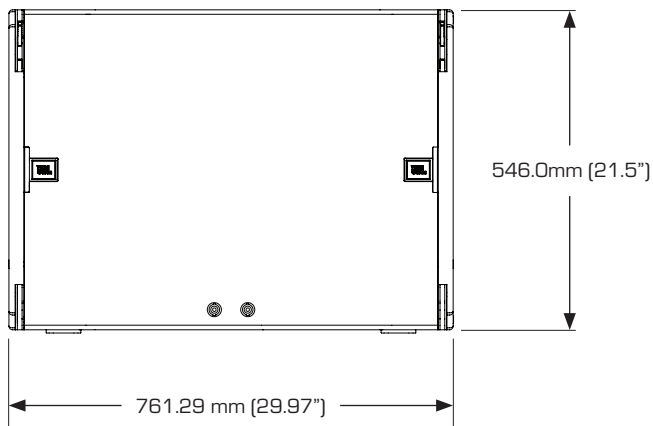

18 - CONTACT INFORMATION

Harman Professional Headquarters

8500 Balboa Blvd.
Northridge, CA 91329
USA
+1 (800) 852-5776
www.jblpro.com

Worldwide Customer Service:

Monday - Friday
8:00am - 5:00pm PCT
(800) 8JBLPRO (800.852.5776)
support@jblpro.com
www.JBLservice.com

HARMAN USA Technical Support:

Monday - Friday
8:00am - 5:00pm
+1-844-776-4899
hprotechsupportusa@harman.com
www.harman.com

Harman Professional London

Harman, Westside
Hemel Hempstead, HP3 9TD
London, UK
+44 (0)1707 668034
www.harman.com

Harman Professional Singapore

108 Pasir Panjang Road
#02-08 Golden Agri Plaza
Singapore 118535
+65 6870-5000
www.harman.com

Harman Professional Shenzhen

20F, China Merchants Port Plaza, #1
Gongye 3rd Road, Shekou, Nanshan Dist.
Shenzhen, 518067, China
+86 755 8634 3702
www.harman.com

Harman Professional India

Prestige Technology Park
Jupiter 2A Block, 4th Floor
Marathahalli Ring Road
Bangalore 560103, India
+918049365905
www.harman.com

Professional Contacts, Outside the USA:

Contact the JBL Professional Distributor in your area.

A complete list of JBL Professional international distributors is provided at our U.S.A. website: www.jblpro.com

